

2022

EXPRESS
YOURSELF

SERENISSIMA 

www.serenissima.re.it

INDEX

by
letter

4	GUIDA ALLA CONSULTAZIONE Consultation guide Guide de consultation Leseverzeichnis Руководство по Работе с Каталогом	114	ÀCANTO
6	INDEX BY EFFECT	136	CHARWOOD
6	INDEX BY SIZE	82	COSTRUIRE
8	EFFECT & COLOURS	190	DUOMO
234	SCHEMI DI POSA Laying sketch Schémas de pose Modulverlegungsbeispiele	48	EVOCA
244	CARATTERISTICHE TECNICHE Technical characteristics Caractéristiques techniques Technische daten	176	FOSSIL
252	POSA E PULIZIA Laying and cleaning Pose et lavage Verlegung und Reinigung	154	GEMME
258	CONDIZIONI GENERALI DI VENDITA General terms of sale Conditions generales de vente Allgemeine verkaufsbedingungen	100	I ROVERI
		166	MAGISTRA
		16	MATERICA
		130	NEWPORT 2.0
		120	NORWAY
		64	PROMENADE
		196	RIABITA IL COTTO
		204	SHOWALL
		32	STUDIO 50
		144	TRAVERTINI DUE
		212	SERENISSIMA DICIANNOVE

Collezioni ceramiche dall'eleganza sicura e funzionale, progettate per offrire moderne risposte alle esigenze del mercato globale.

Fondata nel 1968 dal Cav. Lamberto Romani, Serenissima Ceramiche è l'azienda del Gruppo Romani specializzata nella produzione di collezioni in gres porcellanato destinate a un uso residenziale e commerciale leggero: superfici dalle elevate caratteristiche tecniche, capaci al contempo di distinguersi sul mercato per l'indubbia originalità estetica.

Ceramic collections with a reliable and practical elegance, designed to meet the requirements of the global market with a modern touch. Serenissima Ceramiche, founded by Cav. Lamberto Romani in 1968, is Gruppo Romani's company specialised in manufacturing porcelain stoneware collections for discrete residential and commercial use: high-tech surfaces which also stand out in the market thanks to their undeniably original look.

Collections céramiques d'une élégance indéniable et fonctionnelle, conçues pour offrir des réponses modernes aux besoins du marché mondial. Fondée en 1968 par le Chev. Lamberto Romani, la société Serenissima Ceramiche, qui appartient à Gruppo Romani, est spécialisée dans la production de collections en grès cérame à usage résidentiel et commercial léger : des surfaces aux caractéristiques techniques élevées, qui se distinguent en même temps sur le marché par leur originalité esthétique incontestable.

Keramikkollektionen, die eine sichere und funktionelle Eleganz zeigen und moderne Lösungen für die Bedürfnisse des globalen Marktes bieten. Serenissima Ceramiche wurde 1968 vom Cav. Lamberto Romani gegründet und ist das Unternehmen der Unternehmensgruppe Gruppo Romani, das in der Produktion von Feinsteinzeugkollektionen für den Wohnungs- und leichten Gewerbebau spezialisiert ist: Oberflächen mit hohen technischen Leistungen, die sich zugleich auf dem Markt durch ihre zweifellos originelle Ästhetik unterscheiden.

Коллекции керамики излучают уверенную и функциональную элегантность и разработаны, чтобы предлагать современный ответ на необходимости глобального рынка. Компания Serenissima Ceramiche, основанная в 1968 году Кавалером Труда Ламберто Романи, является частью Группы Romani и специализируется в выпуске керамогранитных коллекций для жилых и коммерческих объектов с невысокой интенсивностью хождения. Эти материалы обладают высокими техническими характеристиками, способными выделяться на рынке своей несомненной эстетической оригинальностью.

SERENISSIMA 

www.serenissima.re.it



EXPR- ESS YOUR- SELF

Serenissima è sinonimo di creatività e di eleganza, fra innovazione tecnologica e autentica tradizione made in Italy. Le collezioni firmate Serenissima esprimono un ideale di bellezza senza tempo e un'eleganza misurata. Nate da un'innata creatività e da un'assidua attività di ricerca, raccontano l'evoluzione di una lunga tradizione tutta italiana, oggi più che mai attenta all'ambiente.

Serenissima stands for creativity and elegance, both state-of-the-art and true to the traditional Made in Italy style. Serenissima's collections express a timeless beauty ideal and a moderate elegance. Stemming from natural creativity and assiduous research activities, they express the long evolution of a typically Italian tradition, which is increasingly environmentally conscious.

Serenissima est synonyme de créativité et d'élégance, entre innovation technologique et tradition authentique du Made in Italy. Les collections signées Serenissima expriment un idéal de beauté intemporelle et d'élégance mesurée. Fruit d'une créativité innée et d'une recherche assidue, elles racontent l'évolution d'une longue tradition italienne, aujourd'hui plus que jamais respectueuse de l'environnement.

Serenissima steht für Kreativität und Eleganz, zwischen technologischer Innovation und authentischer Made in Italy Tradition. Die Kollektionen von Serenissima offenbaren ein zeitloses Schönheitsideal und eine gemessene Eleganz. Sie entstehen aus einer angeborenen Kreativität und einer strebsamen Forschungsaktivität, zeugen von der Evolution einer langen und gänzlich italienischen Tradition, die heute mehr denn je auf die Umwelt achtet.

Serenissima - это синоним креативности и элегантности, которые опираются на технологические инновации и исконные традиции "Made in Italy". Коллекции от Serenissima выражают собой безупречную красоту вне времени и выверенную элегантность. Появившись на свет благодаря врожденной креативности и тщательной исследовательской деятельности, они рассказывают об эволюции великих итальянских традиций, которые сегодня, как никогда ранее, тщательно заботятся об окружающей среде.

FORMATI / SPESSORE
Sizes / Thickness
Formats / Épaisseur
Formaten / Stärke
Форматы / Толщина

FINITURA
Finishing
Finition
Finish
Отделка

COLORI
Colors
Couleurs
Farben
Цвета

CARATTERISTICHE TECNICHE
Technical characteristics
Caracteristiques Techniques
Technische Eigenschaften
Технические характеристики

NOME SERIE
Serie name
Nom de série
Nom de série
Name der Kollektion
Название серии





STUDIO 50

tradizione creativa



GRES PORCELLANATO SMALTATO COLORATO IN MASSA
GLAZED PORCELAIN STONEWARE WITH ENCLOSED BODY
GRÉS CÉRAMÉ ÉMAILLÉ COLORÉ DANS LA MASSE
GLASIERTES FENSTENZUGLIT IN DER MASSE
ГЛАЗУРОВАННЫЙ КЕРАМОГРАНИТ, ОКРАШЕННЫЙ ПО ВСЕЙ ТООЩИНЕ

Colours

Studio Corvino

Studio Petro

Studio Perla

Studio Sabbia

Studio Terracotta

Studio Verderame

Finishes

MATT

GRIP

Sizes $\pm 8,5 \text{ mm} - \frac{1}{16}''$ $\pm 9,5 \text{ mm} - \frac{1}{8}''$

100x100
40" x 40"

120x120
48" x 48"

60x120
24" x 48"

80x80
32" x 32"

60x60
24" x 24"

30x60
12" x 24"

Studio Terracotta 120x120 - 48"x48" rett

32 Catalogo Generale 2022

NOME SERIE
Serie name
Nom de série
Name der Kollektion
Название серии

PEZZI SPECIALI
Trims
Pièces spéciales
Formstücke
Специальные изделия

IMBALLAGGI
Packing
Emballages
Verpackung
Упаковка

EFFETTO
Effect
Effet
Wirkung
Эффект

STUDIO 50

Mosaics $\pm 9,5 \text{ mm} - \frac{1}{8}''$

30x30 - 12"x12"
Foglio, Sheet, Feuille, Blatt, Aum

1069275 Mosaico Corvino tessera 5x5 - 2"x2" rett ● B13

1069276 Mosaico Petro tessera 5x5 - 2"x2" rett ● B13

1069279 Mosaico Perla tessera 5x5 - 2"x2" rett ● B13

1069281 Mosaico Sabbia tessera 5x5 - 2"x2" rett ● B13

1069282 Mosaico Terracotta tessera 5x5 - 2"x2" rett ● B13

1069284 Mosaico Verderame tessera 5x5 - 2"x2" rett ● B13

1069310 Mosaico Random Corvino rett ● B23

1069312 Mosaico Random Petro rett ● B23

1069313 Mosaico Random Perla rett ● B23

1069314 Mosaico Random Sabbia rett ● B23

1069315 Mosaico Random Terracotta rett ● B23

1069316 Mosaico Random Verderame rett ● B23

Decors* $\pm 9,5 \text{ mm} - \frac{1}{8}''$

1069341 Insetto Rococò Green s/4 30x30 - 12"x12" rett ● B26

1069344 Insetto Rococò Red s/4 30x30 - 12"x12" rett ● B26

1069349 Insetto Pop Green s/8 30x30 - 12"x12" rett ● B26

1069347 Insetto Pop Grey s/8 30x30 - 12"x12" rett ● B26

Trims $\pm 9,5 \text{ mm} - \frac{1}{8}''$ $\pm 8,5 \text{ mm} - \frac{1}{16}''$

Battiscopa 6,5x60 - 2 1/2"x24" rett ● C5

1069323 Studio Corvino

1069324 Studio Petro

1069325 Studio Perla

1069326 Studio Sabbia

1069327 Studio Terracotta

1069328 Studio Verderame

Battiscopa 6,5x100 - 2 1/2"x40" rett ● C7

1069317 Studio Corvino

1069318 Studio Petro

1069319 Studio Perla

1069320 Studio Sabbia

1069321 Studio Terracotta

1069322 Studio Verderame

Gradone Costa Retta 30x120x3,3 - 12"x48"x1 1/8" rett ● B51

1069329 Studio Corvino

1069330 Studio Petro

1069331 Studio Perla

1069332 Studio Sabbia

1069333 Studio Terracotta

1069334 Studio Verderame

Gradone Square Assemblato 30x120x3,3 - 12"x48"x1 1/8" rett ● B62

1069335 Studio Corvino

1069336 Studio Perla

1069337 Studio Petro

1069338 Studio Sabbia

1069339 Studio Terracotta

1069340 Studio Verderame

	PZ	BOX		PALLET	
		SQM	KG	SQM	KG
100x100 - 40"x40" rett / R11 / Carpet	2	2,00	34,00	24	40,00
120x120 - 48"x48" rett	1	1,44	31,00	40	57,60
80x80 - 32"x32" rett	2	1,28	27,50	44	56,32
60x120 - 24"x48" rett	2	1,44	31,00	36	51,84
60x60 - 24"x24" rett / R11 / Carpet	3	1,08	22,80	40	43,20
30x60 - 12"x24" rett	6	1,08	22,80	40	43,20
Battiscopa 6,5x60 - 2 1/2"x24" rett	12	7,20 ml	11,00		
Battiscopa 6,5x100 - 2 1/2"x40" rett	6	6,00 ml	9,00		
Gradone Costa Retta 30x120x3,3 - 12"x48"x1 1/8" rett	4		34,00		
Gradone Square Assemblato 30x120x3,3 - 12"x48"x1 1/8" rett	2		19,00		

* Decori da rivestimento ad uso residenziale interno. Wall decorations for interior residential. Décor mural pour usage résidentiel intérieur. Wanddekore nur für Innenbereich geeignet. Декоры для отделки стен - только для помещений.

46 Catalogo Generale 2022



SPESSORE
Thickness
Épaisseur
Stärke
Толщина



SCIVOLosità
Skid
Glissement
Frottement
Скользкость



VARIAZIONI DI TONO
Shade variations
Variations de nuance
Tonvariationen
Стонализированная



PAVIMENTO
Floor tiles
Sols
Bodenfliesen
Пол



RIVESTIMENTO
Wall tiles
Murs
Wandfliesen
Отделка



INGELIVO
Frost proof
Résistant au gel
Frostsicher
Мороустойчивая

FINITURE
SURFACE FINISHES
FINITIONS
OBERFLÄCHENFINISHS
ОТДЕЛКИ

NAT
Naturale - Matt Finish - Nature
Natur - Натуральная

RETT
Rettificato - Rectified - Rectifié
Kalibriert - Ретифицированная

LAPP-RETT
Lappato Rettificato - Honed Rectified
Semi-poli Rectifié - Teilpoliert Kalibriert
Шлифованная ретифицированная

LUX-RETT
Levigato Rettificato - Polished Rectified
Poli Rectifié - Poliert Kalibriert
Полированная ретифицированная

MOSAICI / DECORI
Mosaics / Decors
Mosaïques / Décors
Mosaiken / Dekore
Мозаика / Декоры



1069284 Mosaico Verderame tessera 5x5 - 2"x2" rett ● B13

PEZZI PER SCATOLA
Pieces per box
Pièces par boîte
Stück pro Karton
Штук в коробке

FASCE PREZZO
Price ranges
Grupes des prix
Preisgruppen
Ценовые сегменты

PREZZO AL m²
Price x sqm
Prix / m²
Preis x qm
Цена за квадратный метр

PREZZO AL m LINEARE
Price per linear metre
Prix au m linéaire
Preis pro Laufmeter
Цена за погонный м

PREZZO AL PEZZO
Price per piece
Prix a l'unité
Preis pro Stück
Цена за штуку

by effect

concrete & stone

- 48 EVOCA
- 16 MATERICA
- 64 PROMENADE
- 32 STUDIO 50

metal

- 82 COSTRUIRE

wood

- 114 ÀCANTO
- 136 CHARWOOD
- 100 I ROVERI
- 130 NEWPORT 2.0
- 120 NORWAY

marble

- 190 DUOMO
- 176 FOSSIL
- 154 GEMME
- 166 MAGISTRA
- 144 TRAVERTINI DUE

cotto

- 196 RIABITA IL COTTO

decor

- 204 SHOWALL

by size

✂ 8,5 mm - 5/16"



80x180 . 32"x72"

- 82 COSTRUIRE
- 154 GEMME
- 166 MAGISTRA



100x100 . 40"x40"

- 82 COSTRUIRE
- 48 EVOCA
- 176 FOSSIL
- 154 GEMME
- 166 MAGISTRA
- 16 MATERICA
- 64 PROMENADE
- 32 STUDIO 50
- 144 TRAVERTINI DUE



50x100 . 20"x40"

- 82 COSTRUIRE
- 48 EVOCA
- 154 GEMME

✂ 10 mm - 3/8"



18x118 . 7 1/16"x46 7/16"

- 136 CHARWOOD



40x80 . 16"x32"

- 190 DUOMO
- 196 RIABITA IL COTTO



40x40 . 16"x16"

- 190 DUOMO
- 196 RIABITA IL COTTO



20x40 . 8"x16"

- 190 DUOMO
- 196 RIABITA IL COTTO



20x20 . 8"x8"

- 190 DUOMO
- 196 RIABITA IL COTTO



10x20 . 4"x8"

- 190 DUOMO

✂ 9,5 mm - 3/8"



120x120 . 48"x48"

- 16 MATERICA
- 64 PROMENADE
- 32 STUDIO 50
- 204 SHOWALL



60x120 . 24"x48"

- 82 COSTRUIRE
- 48 EVOCA
- 176 FOSSIL
- 154 GEMME
- 166 MAGISTRA
- 16 MATERICA
- 64 PROMENADE
- 32 STUDIO 50
- 204 SHOWALL
- 144 TRAVERTINI DUE



30x120 . 12"x48"

- 114 ÀCANTO
- 82 COSTRUIRE
- 176 FOSSIL
- 100 I ROVERI
- 16 MATERICA
- 130 NEWPORT 2.0
- 120 NORWAY

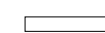

20x120 . 8"x48"

- 114 ÀCANTO
- 100 I ROVERI
- 130 NEWPORT 2.0
- 120 NORWAY

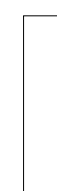

60x240 . 24"x96"

- 204 SHOWALL



60x60 . 24"x24"

- 82 COSTRUIRE
- 48 EVOCA
- 176 FOSSIL
- 154 GEMME
- 166 MAGISTRA
- 16 MATERICA
- 64 PROMENADE
- 32 STUDIO 50
- 144 TRAVERTINI DUE



30x60 . 12"x24"

- 82 COSTRUIRE
- 18 EVOCA
- 176 FOSSIL
- 154 GEMME
- 166 MAGISTRA
- 16 MATERICA
- 64 PROMENADE
- 32 STUDIO 50
- 144 TRAVERTINI DUE

IN- DEX

✂ 19 mm - 13/16"



80x80 . 32"x32"

- 48 EVOCA
- 16 MATERICA
- 32 STUDIO 50



10x40 . 4"x16"

- 100 I ROVERI



100x100 . 40"x40"

- 214 STUDIO 50



80x80 . 32"x32"

- 212 MATERICA



60x120 . 24"x48"

- 218 EVOCA
- 220 PROMENADE



30x120 . 12"x48"

- 222 I ROVERI



60x60 . 24"x24"

- 220 PROMENADE
- 224 RIABITA IL COTTO
- 214 STUDIO 50

concrete & stone

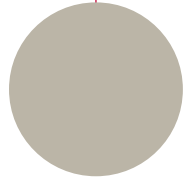

metal

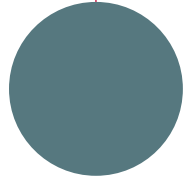

wood

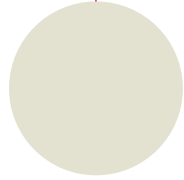

marble

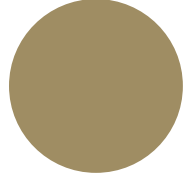

cotto

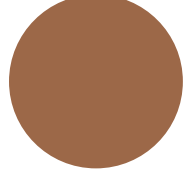

decors

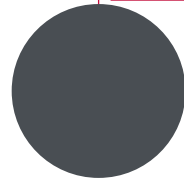

EFFEFFECT & COLOURS

Un mondo di materie, colori, emozioni dove ognuno può trovare la sua idea di stile. Creatività, sapienza tecnica e nuove tecnologie definiscono l'eccellenza nelle superfici d'arredo.

It is a world made of matter, colour and emotion where anyone can find the style they have in mind. Creativity, technical skills and state-of-the-art technologies set the excellent standards of surface coverings.

Un univers de matières, de couleurs, d'émotions où chacun peut trouver sa propre idée de style. La créativité, le savoir-faire technique et les nouvelles technologies définissent l'excellence dans les surfaces de décoration.

Eine Welt der Farben, Materialien und Emotionen, in der jeder seine Stillösung finden kann. Kreativität, Fachwissen und neue Technologien definieren den erstklassigen Charakter der Einrichtungsoberflächen.

Целый мир материалов, цветов и эмоций, в котором каждый может найти свое собственное представление о стиле. Креативность, техническая компетенция и новые технологии являются выражением превосходства в производстве керамических поверхностей.

concrete & stone

MATERICA

8,5 mm - 5/16" 9,5 mm - 3/8" 19 mm - 13/16"

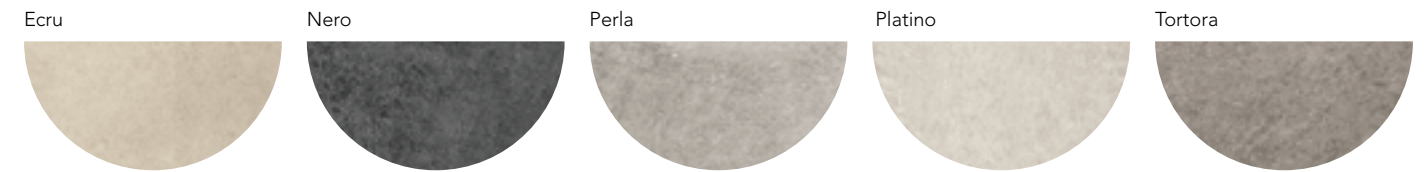

STUDIO 50

8,5 mm - 5/16" 9,5 mm - 3/8" 19 mm - 13/16"

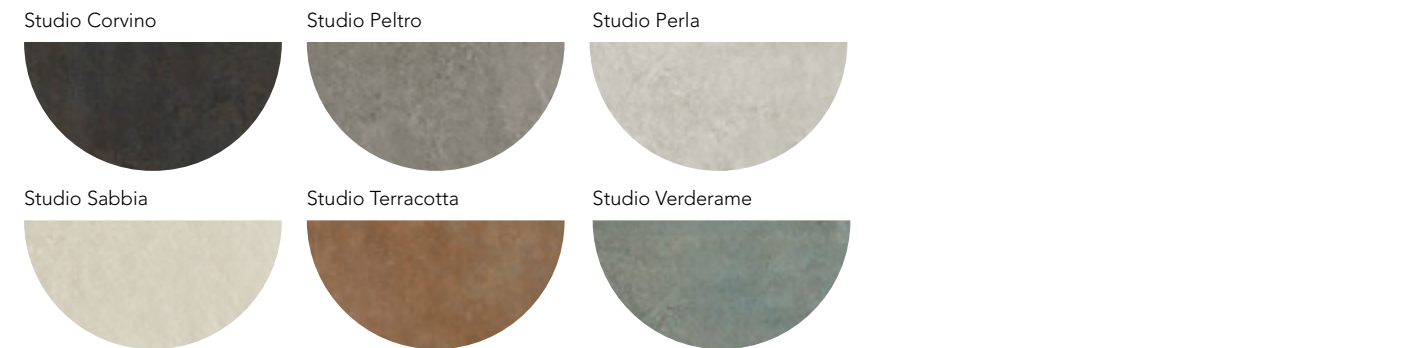

EVOCA

8,5 mm - 5/16" 9,5 mm - 3/8" 19 mm - 13/16"

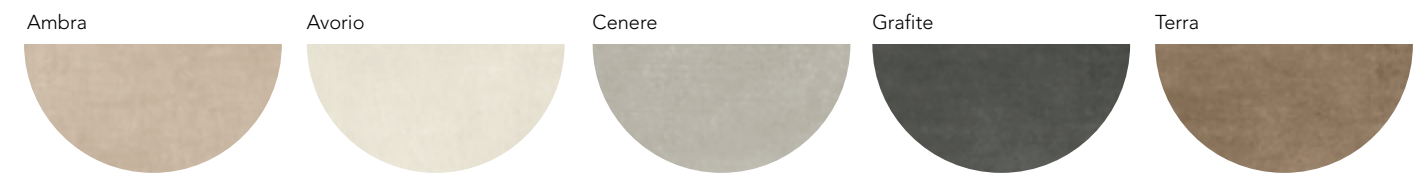

PROMENADE

8,5 mm - 5/16" 9,5 mm - 3/8" 19 mm - 13/16"

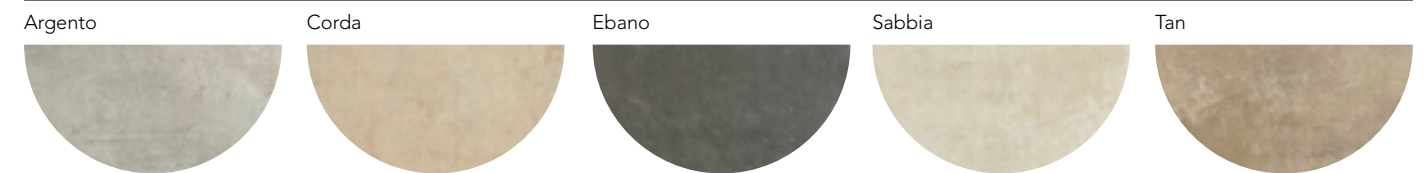

metal

COSTRUIRE

8,5 mm - 5/16" 9,5 mm - 3/8"



wood

I ROVERI

✂ 9,5 mm - 3/8"

✂ 19 mm - 13/16"

Rovere Antico



Rovere Decapè



Rovere Intenso



Rovere Naturale



ÀCANTO

✂ 9,5 mm - 3/8"

Bianco



Grigio



Miele



Noce



Rovere



NORWAY

✂ 9,5 mm - 3/8"

Beautiful Shade



Golden Sunset



Long Night

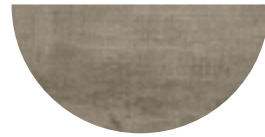

Natural Feeling



Nordic Land



Norway Mix Cold

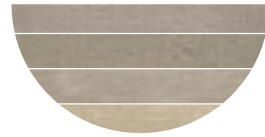

NEWPORT 2.0

✂ 9,5 mm - 3/8"

New Ash



New Birch



New Fir



New Maple



CHARWOOD

✂ 10 mm - 3/8"

Ash



Burned



Carbon



marble

TRAVERTINI DUE

✂ 8,5 mm - 5/16"

✂ 9,5 mm - 3/8"

Beige



Bianco



Greige



GEMME

✂ 8,5 mm - 5/16"

✂ 9,5 mm - 3/8"

Breccia Sabbia



Black Mirror



Colorado



Daino



Saturnia



MAGISTRA

✂ 8,5 mm - 5/16"

✂ 9,5 mm - 3/8"

Cappuccino



Corinthian



Fior Di Bosco

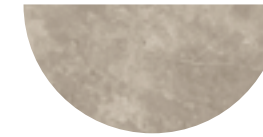

Marquinia

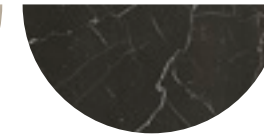

Paonazetto



FOSSIL

✂ 8,5 mm - 5/16"

✂ 9,5 mm - 3/8"

Bruno



Crema



Perla



Piombo

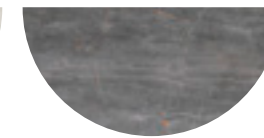

DUOMO

✂ 10 mm - 3/8"

Bianco



Crema



Grigio



Noce



cotto

RIABITA IL COTTO

10 mm - 3/8"

19 mm - 13/16"

Classic



Minimal



Natural



Shabby Chic



decors

SHOWALL

9,5 mm - 3/8"

Wall01 Art Deco



Wall02 Myfair Grey



Wall03 Myfair White



Wall04 Hypnotic



Wall05 Mahori



Wall06 Black Leaf



Wall07 White Leaf



Wall08 Garden



Wall09 Jungle



Wall10 Spring



Wall11 Fabulous Pink



Wall12 Fabulous Blue



Wall13 Fenice



Wall14 Forest



Wall15 Monkey



Wall16 Romeo and Juliet



Wall17 Palm Beach



Wall18 Amazonia Blu



Wall19 Wonderland



Wall20 Fontana

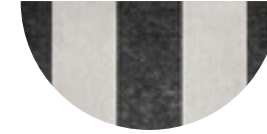

Wall21 Mondrian



Wall22 Odalisca



1

concrete &
stone

16 MATERICA
32 STUDIO 50
48 EVOCA
64 PROMENADE



MATERICA

fascino concreto

concrete
& stone

GRES PORCELLANATO SMALTATO COLORATO IN MASSA
 GLAZED PORCELAIN STONEWARE WITH COLOURED BODY
 GRÈS CÉRAME ÉMAILLÉ COLORÉ DANS LA MASSE
 GLASIERTES FEINSTEINZEUG IN DER MASSE GEFÄRBT
 ГЛАЗУРОВАННЫЙ КЕРАМОГРАНИТ, ОКРАШЕННЫЙ ПО ВСЕЙ ТООЛЩИНЕ



Colours

Ecru



Nero

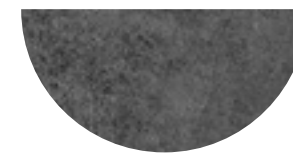

Perla

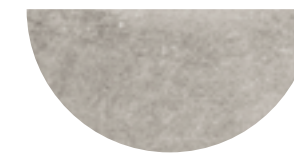

Platino

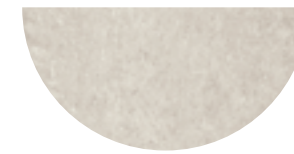

Tortora

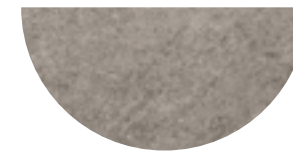

Finishes

MATT



GRIP

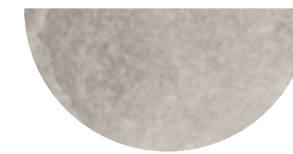

BRICK MIX



Sizes ➤ 8,5 mm - 5/16"

➤ 9,5 mm - 3/8"

100x100
40"x40"



120x120
48"x48"

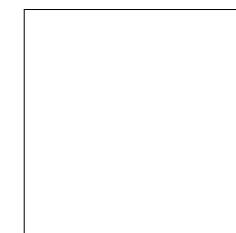

60x120
24"x48"

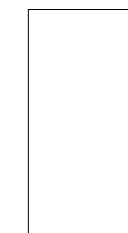

Brick
30x120
12"x48"



80x80
32"x32"

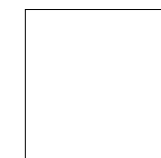

60x60
24"x24"

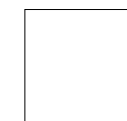

30x60
12"x24"



Ecru 60x120 . 24"x48" rett - Brick Mix 30x120 . 12"x48" rett



Ecru 60x120 . 24"x48" rett



Tortora 80x80 . 32"x32" rett



BE
THE
CHANGE



Perla 120x120 . 48"x48" rett
Platino 60x120 . 24"x48" rett
Wall07 White Leaf (comp. 2pz) 120x120 . 48"x48" rett (Collezione Showall vedi pag. 204)



Nero 120x120 . 48"x48" rett
 Wall02 Myfair Grey 60x120 . 24"x48" rett (Collezione Showall vedi pag. 204)
 E.lements Perla



Nero 80x80 . 32"x32" rett
 Wall22 Odalisca (comp. 2pz) 60x240 . 24"x96" rett (Collezione Showall vedi pag. 204)
 E.lements Nero

concrete
& stone

MATERICA

Colours

Ecru



✂ 8,5 mm - 5/16"

1075369 100x100 . 40"x40" rett ■ **A32**
1075374 100x100 . 40"x40" R11 rett ■ **A34**



1075379 120x120 . 48"x48" rett ■ **A44**

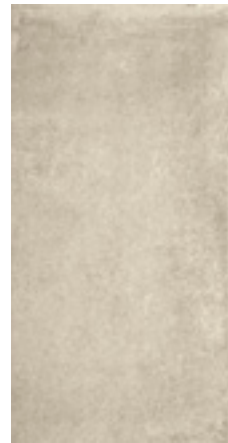

1075344 60x120 . 24"x48" rett ■ **A29**



1076617 Brick Mix Ecru 30x120 . 12"x48" rett ■ **A39**

✂ 9,5 mm - 3/8"



1075364 80x80 . 32"x32" rett ■ **A26**



1075349 60x60 . 24"x24" rett ■ **A13**
1075354 60x60 . 24"x24" R11 rett ■ **A14**

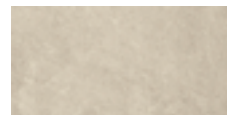

1075359 30x60 . 12"x24" rett ■ **A10**

Nero



✂ 8,5 mm - 5/16"

1075370 100x100 . 40"x40" rett ■ **A32**



1075380 120x120 . 48"x48" rett ■ **A44**



1075345 60x120 . 24"x48" rett ■ **A29**

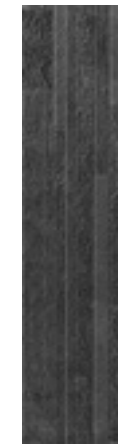

1076618 Brick Mix Nero 30x120 . 12"x48" rett ■ **A39**

✂ 9,5 mm - 3/8"



1075365 80x80 . 32"x32" rett ■ **A26**



1075350 60x60 . 24"x24" rett ■ **A13**

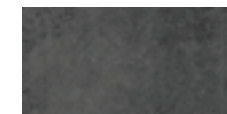

1075360 30x60 . 12"x24" rett ■ **A10**



MATERICA

Colours

Perla



✂ 8,5 mm - 5/16"

1075371 100x100 . 40"x40" rett ■ A32
1075376 100x100 . 40"x40" R11 rett ■ A34

Platino



✂ 8,5 mm - 5/16"

1075372 100x100 . 40"x40" rett ■ A32
1075377 100x100 . 40"x40" R11 rett ■ A34

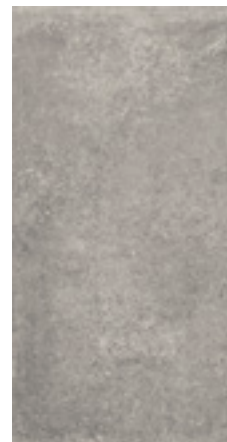

✂ 9,5 mm - 3/8"

1075381 120x120 . 48"x48" rett ■ A44

1075346 60x120 . 24"x48" rett ■ A29

1076619 Brick Mix Perla 30x120 . 12"x48" rett ■ A39

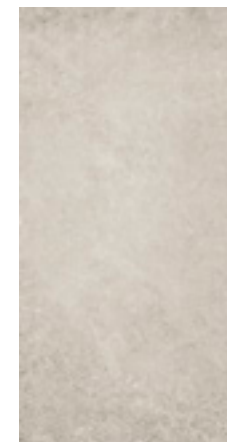
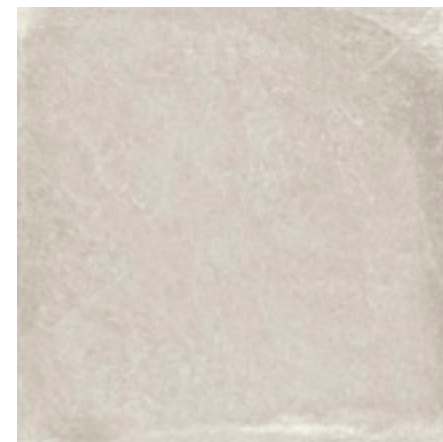

✂ 9,5 mm - 3/8"

1075382 120x120 . 48"x48" rett ■ A44

1075347 60x120 . 24"x48" rett ■ A29

1076620 Brick Mix Platino 30x120 . 12"x48" rett ■ A39



1075366 80x80 . 32"x32" rett ■ A26

1075351 60x60 . 24"x24" rett ■ A13
1075356 60x60 . 24"x24" R11 rett ■ A14

1075361 30x60 . 12"x24" rett ■ A10

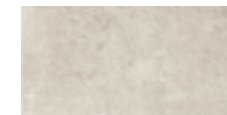

1075367 80x80 . 32"x32" rett ■ A26

1075352 60x60 . 24"x24" rett ■ A13
1075357 60x60 . 24"x24" R11 rett ■ A14

1075362 30x60 . 12"x24" rett ■ A10

MATERICA

Colours



Tortora



✂ 8,5 mm - 5/16"

1075373 100x100 . 40"x40" rett ■ **A32**
1075378 100x100 . 40"x40" R11 rett ■ **A34**



1075383 120x120 . 48"x48" rett ■ **A44**



1075348 60x120 . 24"x48" rett ■ **A29**



1076621 Brick MixTortora 30x120 . 12"x48" rett ■ **A39**

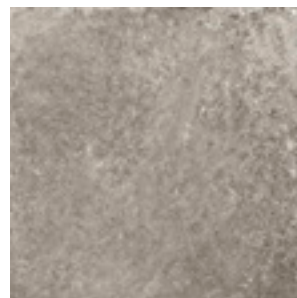

1075368 80x80 . 32"x32" rett ■ **A26**

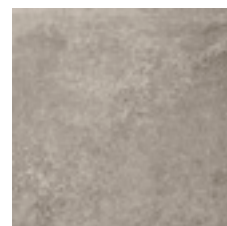

1075353 60x60 . 24"x24" rett ■ **A13**
1075358 60x60 . 24"x24" R11 rett ■ **A14**



1075363 30x60 . 12"x24" rett ■ **A10**

Mosaics ✂ 9,5 mm - 3/8"

30x30 - 12"x12"
Foglio. Sheet. Feuille. Blatt. Лист



1076951 Mosaico Ecrú
 tessera 5x5 . 2"x2"
 rett ● **B13**

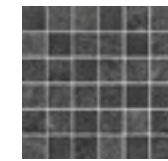

1076952 Mosaico Nero
 tessera 5x5 . 2"x2"
 rett ● **B13**

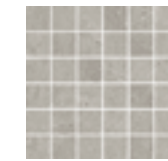

1076953 Mosaico Perla
 tessera 5x5 . 2"x2"
 rett ● **B13**



1076954 Mosaico Platino
 tessera 5x5 . 2"x2"
 rett ● **B13**

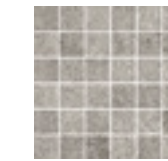

1076955 Mosaico Tortora
 tessera 5x5 . 2"x2"
 rett ● **B13**

25x30 - 10"x12"
Foglio. Sheet. Feuille. Blatt. Лист



1076734 Mosaico Esagona Ecrú
 25x30 . 10"x12"
 rett ● **B19**



1076735 Mosaico Esagona Nero
 25x30 . 10"x12"
 rett ● **B19**



1076736 Mosaico Esagona Perla
 25x30 . 10"x12"
 rett ● **B19**



1076737 Mosaico Esagona Platino
 25x30 . 10"x12"
 rett ● **B19**



1076738 Mosaico Esagona Tortora
 25x30 . 10"x12"
 rett ● **B19**

MATERICA

Trims  9,5 mm - 3/8"



Battiscopa
6,5x60 . 2 9/16"x24" rett ► **C5**
1077504 Ecrú
1077505 Nero
1077506 Perla
1077507 Platino
1077508 Tortora

 8,5 mm - 5/16"



Battiscopa
6,5x100 . 2 9/16"x40" rett ► **C7**
1077927 Ecrú
1077928 Nero
1077929 Perla
1077930 Platino
1077931 Tortora



Gradone Costa Retta
30x120x3,3 . 12"x48"x1 5/16" rett ● **B51**
1078434 Ecrú
1078435 Nero
1078436 Perla
1078437 Platino
1078438 Tortora



Gradone Square Assemblato
30x120x3,3 . 12"x48"x1 5/16" rett ● **B62**
1078439 Ecrú
1078440 Nero
1078441 Perla
1078442 Platino
1078443 Tortora

	BOX			PALLET		
	PZ	SQM	KGS	BOXES	SQM	KGS
100x100 . 40"x40" rett / R11	2	2,00	38,00	24	48,00	950
120x120 . 48"x48" rett	1	1,44	31,00	40	57,60	1.300
80x80 . 32"x32" rett	2	1,28	27,50	44	56,32	1.226
60x120 . 24"x48" rett	2	1,44	31,00	36	51,84	1.144
30x120 . 12"x48" rett brick mix	4	1,44	31,00	24	34,58	760
60x60 . 24"x24" rett / R11	3	1,08	22,80	40	43,20	928
30x60 . 12"x24" rett	6	1,08	22,80	40	43,20	928
Battiscopa 6,5x60 . 2 9/16"x24" rett	12	7,20 ml	10,50			
Battiscopa 6,5x100 . 2 9/16"x40" rett	6	6,00 ml	9,00			
Gradone Costa Retta 30x120x3,3 . 12"x48"x1 5/16" rett	4		34,00			
Gradone Square Assemblato 30x120x3,3 . 12"x48"x1 5/16" rett	2		18,50			



concrete
& stone

Platino 100x100 . 40"x40" rett R11



STUDIO 50

tradizione creativa

concrete
& stone

GRES PORCELLANATO SMALTATO COLORATO IN MASSA
 GLAZED PORCELAIN STONEWARE WITH COLOURED BODY
 GRÈS CÉRAME ÉMAILLÉ COLORÉ DANS LA MASSE
 GLASIERTES FEINSTEINZEUG IN DER MASSE GEFÄRBT
 ГЛАЗУРОВАННЫЙ КЕРАМОГРАНИТ, ОКРАШЕННЫЙ ПО ВСЕЙ ТООЛЩИНЕ

UPEC
 30x60 . 12"x24" RETT → U4 P4 E3 C2
 60x60 . 24"x24" RETT → U4 P4 E3 C2
 80x80 . 32"x32" RETT → U4 P3 E3 C2
 60x120 . 24"x48" RETT → U4 P3 E3 C2



Colours

Studio Corvino



Studio Peltro



Studio Perla



Studio Sabbia



Studio Terracotta



Studio Verderame



Finishes

MATT



GRIP



Sizes ➤ 8,5 mm - 5/16"

➤ 9,5 mm - 3/8"

100x100
40"x40"

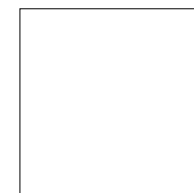

120x120
48"x48"



60x120
24"x48"



80x80
32"x32"



60x60
24"x24"

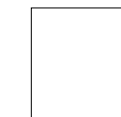

30x60
12"x24"





Studio Terracotta 120x120 . 48"x48" rett / Mosaico Random Terracotta 30x30 . 12"x12" rett



Studio Sabbia 60x120 . 24"x48" rett / Carpet Sabbia 60x60 . 24"x24" rett / Mosaico Sabbia 5x5 . 2"x2" rett



Studio Perla 100x100 . 40"x40" rett



Studio Peltro 100x100 . 40"x40" rett / Carpet Peltro 100x100 . 40"x40" rett



Studio Verderame 120x120 . 48"x48" rett / Inserto Rococò Green s/4 30x30 . 12"x12" rett



Studio Verderame 120x120 . 48"x48" rett
 Studio Verderame 60x60 . 24"x24" R11 19 MM rett

STUDIO 50

Colours

Studio Corvino

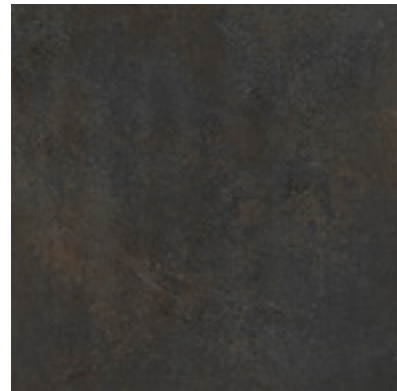

1068017 100x100 . 40"x40" rett ■ **A32**



1068449 Carpet Corvino
100x100 . 40"x40" rett ■ **A40**

✂ 8,5 mm - 5/16"

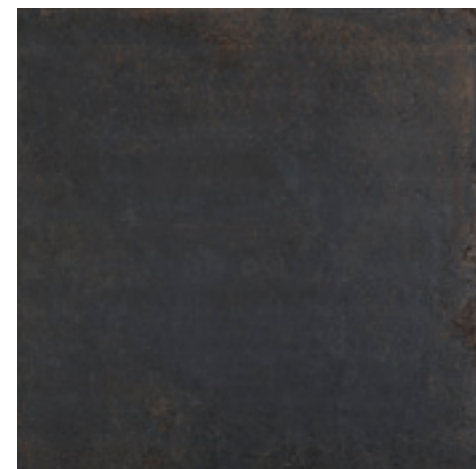

1068025 120x120 . 48"x48" rett ■ **A44**

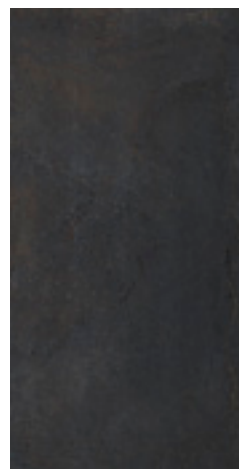

1067925
60x120 . 24"x48" rett ■ **A29**

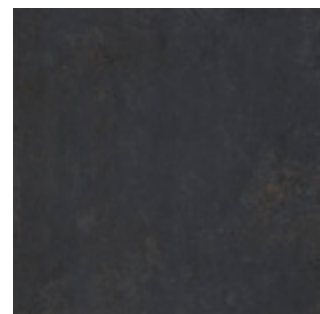

1067908 80x80 . 32"x32" rett ■ **A26**

✂ 9,5 mm - 3/8"

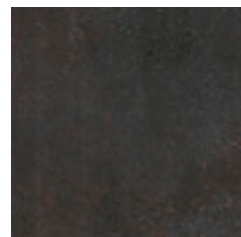

1067933 60x60 . 24"x24" rett ■ **A13**



1068455 Carpet Corvino
60x60 . 24"x24" rett ■ **A22A**



1068462
30x60 . 12"x24" rett ■ **A10**

Studio Peltro



1068018 100x100 . 40"x40" rett ■ **A32**
1068022 100x100 . 40"x40" rett R11 ■ **A34**



1068450 Carpet Peltro
100x100 . 40"x40" rett ■ **A40**

✂ 8,5 mm - 5/16"



1068026 120x120 . 48"x48" rett ■ **A44**



1067926
60x120 . 24"x48" rett ■ **A29**



1067909 80x80 . 32"x32" rett ■ **A26**

✂ 9,5 mm - 3/8"

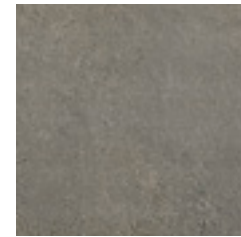

1067934 60x60 . 24"x24" rett ■ **A13**
1067930 60x60 . 24"x24" rett R11 ■ **A14**



1068456 Carpet Peltro
60x60 . 24"x24" rett ■ **A22A**



1068463
30x60 . 12"x24" rett ■ **A10**

STUDIO 50

Colours

Studio Perla



1068019 100x100 . 40"x40" rett ■ **A32**
1068023 100x100 . 40"x40" rett R11 ■ **A34**



1068451 Carpet Perla
100x100 . 40"x40" rett ■ **A40**

✂ 8,5 mm - 5/16"



Studio Sabbia



1068187 100x100 . 40"x40" rett ■ **A32**
1068188 100x100 . 40"x40" rett R11 ■ **A34**



1068452 Carpet Sabbia
100x100 . 40"x40" rett ■ **A40**

✂ 8,5 mm - 5/16"



1068027 120x120 . 48"x48" rett ■ **A44**

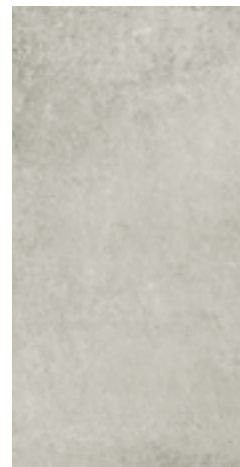

1067927
60x120 . 24"x48" rett ■ **A29**



1067910 80x80 . 32"x32" rett ■ **A26**

✂ 9,5 mm - 3/8"

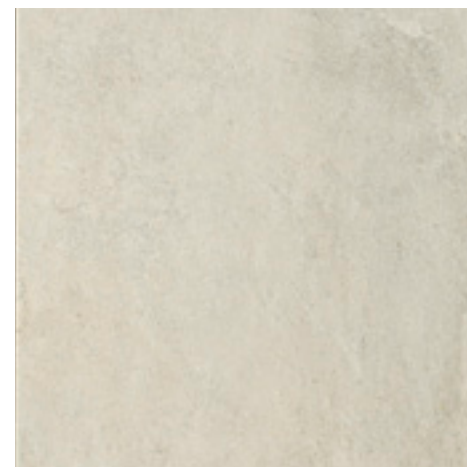

1068186 120x120 . 48"x48" rett ■ **A44**



1068163
60x120 . 24"x48" rett ■ **A29**

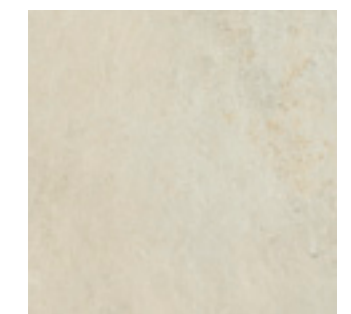

1068539 80x80 . 32"x32" rett ■ **A26**

✂ 9,5 mm - 3/8"



1067935 60x60 . 24"x24" rett ■ **A13**
1067931 60x60 . 24"x24" rett R11 ■ **A14**



1068457 Carpet Perla
60x60 . 24"x24" rett ■ **A22A**

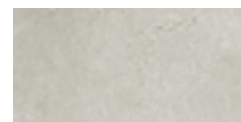

1068464
30x60 . 12"x24" rett ■ **A10**

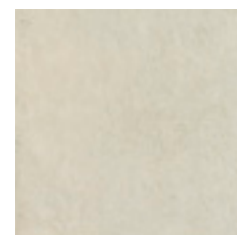

1068165 60x60 . 24"x24" rett ■ **A13**
1068166 60x60 . 24"x24" rett R11 ■ **A14**

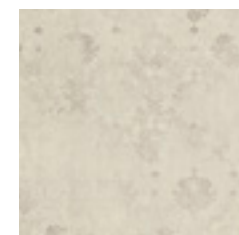

1068458 Carpet Sabbia
60x60 . 24"x24" rett ■ **A22A**



1068465
30x60 . 12"x24" rett ■ **A10**

STUDIO 50

Colours

Studio Terracotta



1068020 100x100 . 40"x40" rett ■ **A32**
1068024 100x100 . 40"x40" rett R11 ■ **A34**



1068453 Carpet Terracotta
 100x100 . 40"x40" rett ■ **A40**

✂ 8,5 mm - 5/16"



1068028 120x120 . 48"x48" rett ■ **A44**

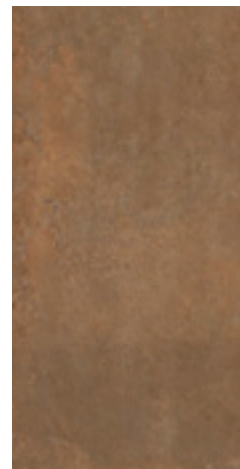

1067928
 60x120 . 24"x48" rett ■ **A29**

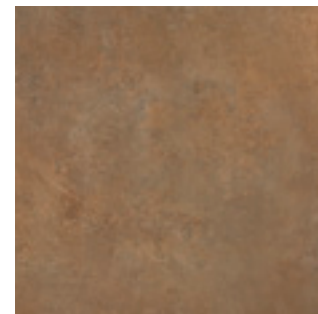

1067911 80x80 . 32"x32" rett ■ **A26**

✂ 9,5 mm - 3/8"

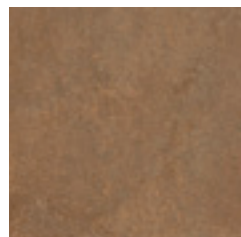

1067936 60x60 . 24"x24" rett ■ **A13**
1067932 60x60 . 24"x24" rett R11 ■ **A14**



1068459 Carpet Terracotta
 60x60 . 24"x24" rett ■ **A22A**

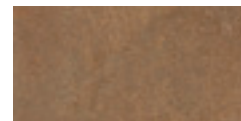

1068466
 30x60 . 12"x24" rett ■ **A10**

Studio Verderame



1068021 100x100 . 40"x40" rett ■ **A32**



1068454 Carpet Verderame
 100x100 . 40"x40" rett ■ **A40**

✂ 8,5 mm - 5/16"



1068029 120x120 . 48"x48" rett ■ **A44**



1067929
 60x120 . 24"x48" rett ■ **A29**



1067912 80x80 . 32"x32" rett ■ **A26**

✂ 9,5 mm - 3/8"

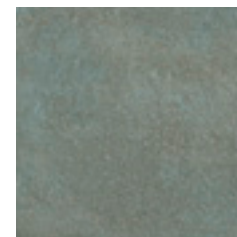

1067937 60x60 . 24"x24" rett ■ **A13**

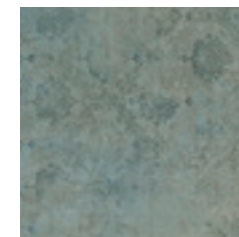

1068460 Carpet Verderame
 60x60 . 24"x24" rett ■ **A22A**





1068467
 30x60 . 12"x24" rett ■ **A10**

STUDIO 50

Mosaics 9,5 mm - 3/8"

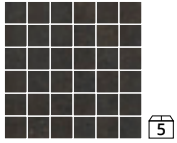
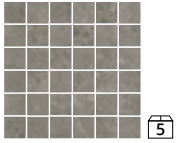
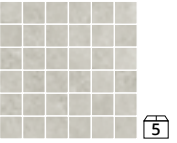
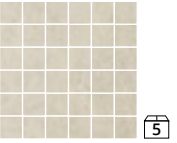
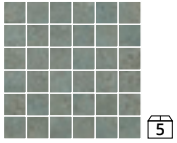
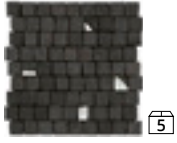
30x30 - 12"x12"
Foglio. Sheet. Feuille. Blatt. Лист

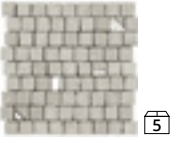
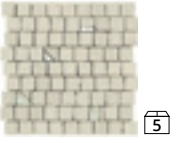
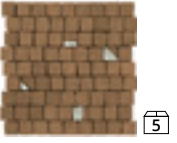
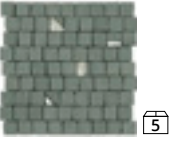
 1069275 Mosaico Corvino tessera 5x5 . 2"x2" rett ● B13	 1069276 Mosaico Peltro tessera 5x5 . 2"x2" rett ● B13	 1069279 Mosaico Perla tessera 5x5 . 2"x2" rett ● B13	 1069281 Mosaico Sabbia tessera 5x5 . 2"x2" rett ● B13	 1069282 Mosaico Terracotta tessera 5x5 . 2"x2" rett ● B13	 1069284 Mosaico Verderame tessera 5x5 . 2"x2" rett ● B13
 1069310 Mosaico Random Corvino rett ● B23	 1069312 Mosaico Random Peltro rett ● B23	 1069313 Mosaico Random Perla rett ● B23	 1069314 Mosaico Random Sabbia rett ● B23	 1069315 Mosaico Random Terracotta rett ● B23	 1069316 Mosaico Random Verderame rett ● B23

Decors* 9,5 mm - 3/8"

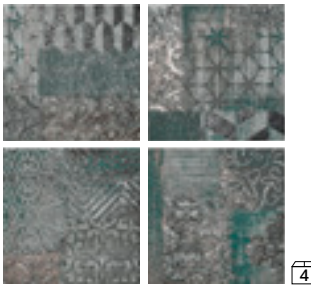
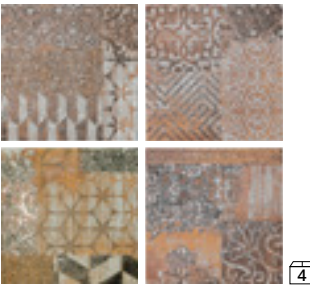
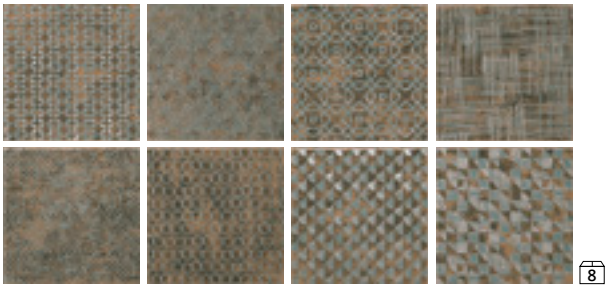
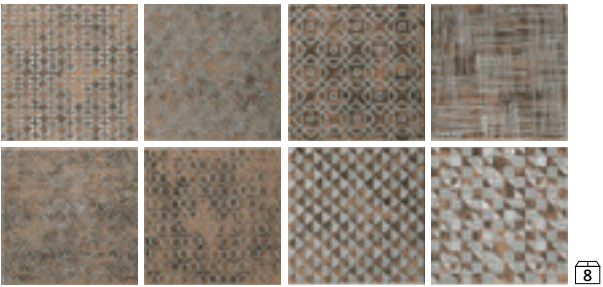
 1069341 Inserto Roccò Green s/4 30x30 . 12"x12" rett ● B26	 1069344 Inserto Roccò Red s/4 30x30 . 12"x12" rett ● B26
 1069349 Inserto Pop Green s/8 30x30 . 12"x12" rett ● B26	 1069347 Inserto Pop Grey s/8 30x30 . 12"x12" rett ● B26

* Decori da rivestimento ad uso residenziale interno. Wall decorations for interior residential.
Décor mural pour usage résidentiel intérieur. Wanddekore nur für Innenbereich geeignet. Декоры для отделки стен жилых помещений.

Trims 9,5 mm - 3/8"

Battiscopa
6,5x60 . 2 9/16"x24" rett ► **C5**
1069323 Studio Corvino
1069324 Studio Peltro
1069325 Studio Perla
1069326 Studio Sabbia
1069327 Studio Terracotta
1069328 Studio Verderame

Gradone Costa Retta
30x120x3,3 . 12"x48"x1 5/16" rett ● **B51**
1069329 Studio Corvino
1069330 Studio Peltro
1069331 Studio Perla
1069332 Studio Sabbia
1069333 Studio Terracotta
1069334 Studio Verderame

Gradone Square Assemblato
30x120x3,3 . 12"x48"x1 5/16" rett ● **B62**
1069335 Studio Corvino
1069337 Studio Perla
1069336 Studio Peltro
1069338 Studio Sabbia
1069339 Studio Terracotta
1069340 Studio Verderame

8,5 mm - 5/16"

Battiscopa
6,5x100 . 2 9/16"x40" rett ► **C7**
1069317 Studio Corvino
1069318 Studio Peltro
1069319 Studio Perla
1069320 Studio Sabbia
1069321 Studio Terracotta
1069322 Studio Verderame

	BOX			PALLET		
	PZ	SQM	KGS	BOXES	SQM	KGS
100x100 . 40"x40" rett / R11 / Carpet	2	2,00	34,00	24	48,00	950
120x120 . 48"x48" rett	1	1,44	31,00	40	57,60	1.300
80x80 . 32"x32" rett	2	1,28	27,50	44	56,32	1.226
60x120 . 24"x48" rett	2	1,44	31,00	36	51,84	1.144
60x60 . 24"x24" rett / R11 / Carpet	3	1,08	22,80	40	43,20	928
30x60 . 12"x24" rett	6	1,08	22,80	40	43,20	928
Battiscopa 6,5x60 . 2 9/16"x24" rett	12	7,20 ml	11,00			
Battiscopa 6,5x100 . 2 9/16"x40" rett	6	6,00 ml	9,00			
Gradone Costa Retta 30x120x3,3 . 12"x48"x1 5/16" rett	4		34,00			
Gradone Square Assemblato 30x120x3,3 . 12"x48"x1 5/16" rett	2		19,00			



EVOCA

intrecci di stile

concrete
& stone

GRES FINE PORCELLANATO SMALTATO
 GLAZED FINE PORCELAIN STONEWAREE
 GRÈS CÉRAME FIN ÉMAILLÉ
 GLASIERTES FEINSTEINZEUG
 ГЛАЗУРОВАННЫЙ КЕРАМОГРАНИТ

UPEC
 30x60 . 12"x24" RETT → U4 P4 E3 C2
 60x60 . 24"x24" RETT → U4 P4 E3 C2
 80x80 . 32"x32" RETT → U4 P3 E3 C2
 60x120 . 24"x48" RETT → U4 P3 E3 C2



Colours

Ambra



Avorio



Cenere



Grafite

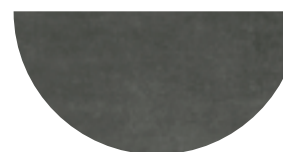

Terra



Finishes

MATT



LAPP



GRIP



Sizes $\pm 8,5 \text{ mm} - \frac{5}{16}''$

100x100
40"x40"

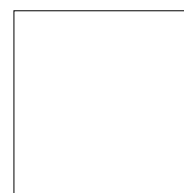

50x100
20"x40"



$\pm 9,5 \text{ mm} - \frac{3}{8}''$

60x120
24"x48"



80x80
32"x32"

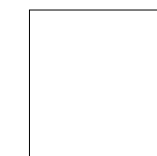

60x60
24"x24"



30x60
12"x24"



Grafite 60x120 . 24"x48" rett / Inserto Rombo Cenere 60x60 . 24"x24" rett



Ambra 80x80 . 32"x32" rett R11



Grafite 100x100 . 40"x40" rett / Gradone Square Assemblato 30x120x3,3 . 12"x48"x1⁵/₁₆" rett



Avorio 100x100 . 40"x40" rett



Cenere 60x120 . 24"x48" lapp-rett

concrete
& stone



Terra 80x80 . 32"x32" rett / Insetto Rombo Ambra 60x60 . 24"x24" rett

Colours

Ambra



1064898 100x100 . 40"x40" rett ■ **A32**
1064894 100x100 . 40"x40" lapp-rett ■ **A40**
1064906 100x100 . 40"x40" rett R11 ■ **A34**



1064918 50x100 . 20"x40" rett ■ **A28**
1064909 50x100 . 20"x40" lapp-rett ■ **A37**

✚ 8,5 mm - 5/16"



1064923 80x80 . 32"x32" rett ■ **A26**
1065152 80x80 . 32"x32" rett R11 ■ **A26A**



1064933 60x120 . 24"x48" rett ■ **A29**
1064928 60x120 . 24"x48" lapp-rett ■ **A38**

✚ 9,5 mm - 3/8"

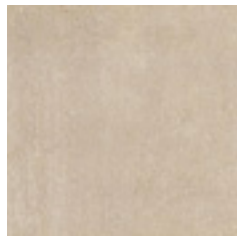

1064943 60x60 . 24"x24" rett ■ **A13**
1064938 60x60 . 24"x24" lapp-rett ■ **A22A**
1064953 60x60 . 24"x24" rett R11 ■ **A14**

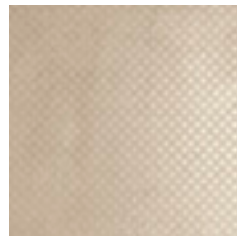

1065252 Inserto Evoca Ambra
 60x60 . 24"x24" lapp-rett ■ **A33**



1065250 Inserto Rombo Ambra
 60x60 . 24"x24" rett ■ **A23**



1064958
 30x60 . 12"x24" rett ■ **A10**

Avorio



1064899 100x100 . 40"x40" rett ■ **A32**
1064895 100x100 . 40"x40" lapp-rett ■ **A40**
1064976 100x100 . 40"x40" rett R11 ■ **A34**



1064919 50x100 . 20"x40" rett ■ **A28**
1064910 50x100 . 20"x40" lapp-rett ■ **A37**

✚ 8,5 mm - 5/16"



1064924 80x80 . 32"x32" rett ■ **A26**
1065153 80x80 . 32"x32" rett R11 ■ **A26A**

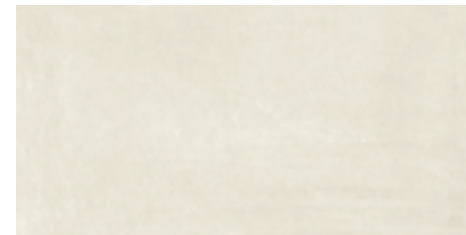

1064934 60x120 . 24"x48" rett ■ **A29**
1064929 60x120 . 24"x48" lapp-rett ■ **A38**

✚ 9,5 mm - 3/8"



1064944 60x60 . 24"x24" rett ■ **A13**
1064939 60x60 . 24"x24" lapp-rett ■ **A22A**
1064954 60x60 . 24"x24" rett R11 ■ **A14**

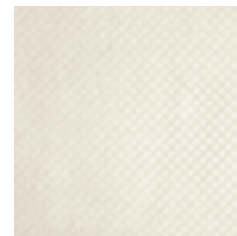

1065253 Inserto Evoca Avorio
 60x60 . 24"x24" lapp-rett ■ **A33**



1064959
 30x60 . 12"x24" rett ■ **A10**

Colours

Cenere



1064901 100x100 . 40"x40" rett ■ **A32**
1064897 100x100 . 40"x40" lapp-rett ■ **A40**
1064908 100x100 . 40"x40" rett R11 ■ **A34**



1064921 50x100 . 20"x40" rett ■ **A28**
1064912 50x100 . 20"x40" lapp-rett ■ **A37**

✂ 8,5 mm - 5/16"



1064926 80x80 . 32"x32" rett ■ **A26**
1065154 80x80 . 32"x32" rett R11 ■ **A26A**



1064936 60x120 . 24"x48" rett ■ **A29**
1064931 60x120 . 24"x48" lapp-rett ■ **A38**

✂ 9,5 mm - 3/8"



1064946 60x60 . 24"x24" rett ■ **A13**
1064941 60x60 . 24"x24" lapp-rett ■ **A22A**
1064956 60x60 . 24"x24" rett R11 ■ **A14**



1065254 Insetto Evoca Cenere
 60x60 . 24"x24" lapp-rett ■ **A33**



1065251 Insetto Rombo Cenere
 60x60 . 24"x24" rett ■ **A23**

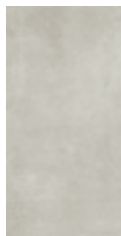

1064961
 30x60 . 12"x24" rett ■ **A10**

Grafite



1064900 100x100 . 40"x40" rett ■ **A32**
1064896 100x100 . 40"x40" lapp-rett ■ **A40**
1064907 100x100 . 40"x40" rett R11 ■ **A34**



1064920 50x100 . 20"x40" rett ■ **A28**
1064911 50x100 . 20"x40" lapp-rett ■ **A37**

✂ 8,5 mm - 5/16"



1064925 80x80 . 32"x32" rett ■ **A26**
1065155 80x80 . 32"x32" rett R11 ■ **A26A**



1064935 60x120 . 24"x48" rett ■ **A29**
1064930 60x120 . 24"x48" lapp-rett ■ **A38**

✂ 9,5 mm - 3/8"



1064945 60x60 . 24"x24" rett ■ **A13**
1064940 60x60 . 24"x24" lapp-rett ■ **A22A**
1064955 60x60 . 24"x24" rett R11 ■ **A14**

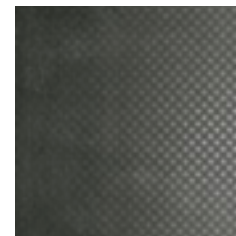

1065255 Insetto Evoca Grafite
 60x60 . 24"x24" lapp-rett ■ **A33**



1065251 Insetto Rombo Cenere
 60x60 . 24"x24" rett ■ **A23**



1064960
 30x60 . 12"x24" rett ■ **A10**

Colours



Terra



1064915 100x100 . 40"x40" rett ■ **A32**
1064913 100x100 . 40"x40" lapp-rett ■ **A40**
1064917 100x100 . 40"x40" rett R11 ■ **A34**



1064922 50x100 . 20"x40" rett ■ **A28**
1064914 50x100 . 20"x40" lapp-rett ■ **A37**

✂ 8,5 mm - 5/16"



1064927 80x80 . 32"x32" rett ■ **A26**
1065156 80x80 . 32"x32" rett R11 ■ **A26A**



1064937 60x120 . 24"x48" rett ■ **A29**
1064932 60x120 . 24"x48" lapp-rett ■ **A38**

✂ 9,5 mm - 3/8"



1064947 60x60 . 24"x24" rett ■ **A13**
1064942 60x60 . 24"x24" lapp-rett ■ **A22A**
1064957 60x60 . 24"x24" rett R11 ■ **A14**



1065256 Inserto Evoca Terra
 60x60 . 24"x24" lapp-rett ■ **A33**



1065250 Inserto Rombo Ambra
 60x60 . 24"x24" rett ■ **A23**



1064962
 30x60 . 12"x24" rett ■ **A10**

Mosaics ✂ 9,5 mm - 3/8"

30x30 - 12"x12"
 Foglio. Sheet. Feuille. Blatt. Лист



1064977 Mosaico Ambra
 tessera 5x5 . 2"x2" rett ● **B13**



1064978 Mosaico Avorio
 tessera 5x5 . 2"x2" rett ● **B13**



1064980 Mosaico Cenere
 tessera 5x5 . 2"x2" rett ● **B13**



1064979 Mosaico Grafite
 tessera 5x5 . 2"x2" rett ● **B13**

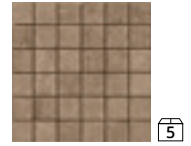

1064981 Mosaico Terra
 tessera 5x5 . 2"x2" rett ● **B13**



1065243 Mosaico
 Losanga Ambra rett ● **B22**



1065244 Mosaico
 Losanga Avorio rett ● **B22**



1065245 Mosaico
 Losanga Cenere rett ● **B22**



1065246 Mosaico
 Losanga Grafite rett ● **B22**



1065247 Mosaico
 Losanga Terra rett ● **B22**



1065249 Mosaico Losanga Warm
 (mix Ambra/Terra) rett ● **B24**



1065248 Mosaico Losanga Cold
 (mix Cenere/Grafite) rett ● **B24**

20x30 - 8"x12"
 Foglio. Sheet. Feuille. Blatt. Лист



1064982 Mosaico Curve Ambra
 20x30 . 8"x12" rett ● **B25**



1064983 Mosaico Curve Avorio
 20x30 . 8"x12" rett ● **B25**



1064985 Mosaico Curve Cenere
 20x30 . 8"x12" rett ● **B25**



1064984 Mosaico Curve Grafite
 20x30 . 8"x12" rett ● **B25**



1064986 Mosaico Curve Terra
 20x30 . 8"x12" rett ● **B25**

EVOCA

Trims  9,5 mm - 3/8"



Battiscopa
6,5x60 . 2 9/16"x24"
rett ► **C5**

- 1065063** Ambra
- 1065064** Avorio
- 1065066** Cenere
- 1065065** Grafite
- 1065067** Terra



Battiscopa
7,5x80 . 3"x32"
rett ► **C7**

- 1065052** Ambra
- 1065053** Avorio
- 1065055** Cenere
- 1065054** Grafite
- 1065056** Terra

 8,5 mm - 5/16"



Battiscopa
6,5x100 . 2 9/16"x40"
rett ► **C7**

- 1065047** Ambra
- 1065048** Avorio
- 1065050** Cenere
- 1065049** Grafite
- 1065051** Terra



Gradone Costa Retta
30x120x3,3 - 12"x48"x1 5/16"
rett ● **B51**

- 1065068** Ambra
- 1065069** Avorio
- 1065071** Cenere
- 1065070** Grafite
- 1065072** Terra



Gradone Square Assemblato
30x120x3,3 - 12"x48"x1 5/16"
rett ● **B62**

- 1065073** Ambra
- 1065074** Avorio
- 1065076** Cenere
- 1065075** Grafite
- 1065077** Terra

	BOX			PALLET		
	PZ	SQM	KGS	BOXES	SQM	KGS
100x100 . 40"x40" rett / lapp-rett / R11	1	1,00	19,00	42	42,00	814
	2	2,00	38,00	24	48,00	950
50x100 . 20"x40" rett / lapp-rett	2	1,00	20,65	42	42,00	900
80x80 . 32"x32" rett / R11	2	1,28	27,50	44	56,32	1.226
60x120 . 24"x48" rett / lapp-rett	2	1,44	31,00	36	51,84	1.144
60x60 . 24"x24" rett / lapp-rett / R11 / inserto evoca	3	1,08	22,80	40	43,20	928
30x60 . 12"x24" rett	6	1,08	22,80	40	43,20	928
Battiscopa 6,5x60 . 2 9/16"x24" rett	12	7,20 ml	11,00			
Battiscopa 7,5x80 . 3"x32" rett	6	4,80 ml	9,00			
Battiscopa 6,5x100 . 2 9/16"x40" rett	6	6,00 ml	7,50			
Gradone Costa Retta 30x120x3,3 . 12"x48"x1 5/16" rett	4		34,00			
Gradone Square Assemblato 30x120x3,3 . 12"x48"x1 5/16" rett	2		19,00			



concrete
& stone

Cenere 60x120 . 24"x48" R11



PROMENADE

bellezza contemporanea

concrete
& stone

GRES FINE PORCELLANATO SMALTATO
 GLAZED FINE PORCELAIN STONEWAREE
 GRÈS CÉRAME FIN ÉMAILLÉ
 GLASIERTES FEINSTEINZEUG
 ГЛАЗУРОВАННЫЙ КЕРАМОГРАНИТ

UPEC 30x60 . 12"x24" RETT → U4 P4 E3 C2
 60x60 . 24"x24" RETT → U4 P4 E3 C2
 60x120 . 24"x48" RETT → U4 P3 E3 C2



Colours

Argento



Corda



Ebano

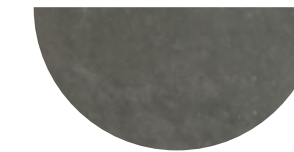

Sabbia



Tan



Finishes

MATT



GRIP

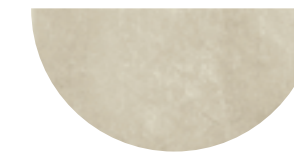

Sizes ➤ 8,5 mm - 5/16"

➤ 9,5 mm - 3/8"

100x100
40"x40"



120x120
48"x48"



60x120
24"x48"



60x60
24"x24"



30x60
12"x24"



Argento 60x60 . 24"x24" R11 rett / Mosaico Bricks Argento 24x40 . 9 7/16"x16" rett



Tan Modulare 40: 60x120 . 24"x48" rett / 60x60 . 24"x24" rett _ 30x60 . 12"x24" rett



Ebano 100x100 . 40"x40" rett / Mosaico Esagona Ebano 25x30 . 10"x12" rett



Corda 120x120 . 48"x48" rett



Sabbia modulare 40 R11: 30x60 . 12"x24" rett / 60x60 . 24"x24" rett / 60x120 . 24"x48" rett

PROMENADE

Colours



Argento



✂ 8,5 mm - 5/16"

1068032 100x100 . 40"x40" rett ■ **A32**

Corda

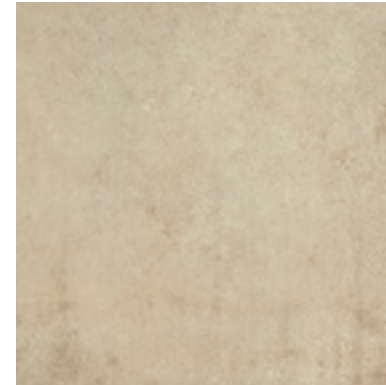

✂ 8,5 mm - 5/16"

1068033 100x100 . 40"x40" rett ■ **A32**



✂ 9,5 mm - 3/8"

1068372 120x120 . 48"x48" rett ■ **A44**

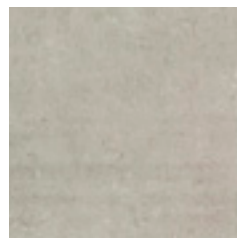

1067749 60x60 . 24"x24" rett ■ **A13**
1069847 60x60 . 24"x24" rett R11 ■ **A14**



1069852 30x60 . 12"x24" rett ■ **A10**
1069857 30x60 . 12"x24" rett R11 ■ **A11**



✂ 9,5 mm - 3/8"

1068373 120x120 . 48"x48" rett ■ **A44**



1067750 60x60 . 24"x24" rett ■ **A13**
1069848 60x60 . 24"x24" rett R11 ■ **A14**



1069853 30x60 . 12"x24" rett ■ **A10**
1069858 30x60 . 12"x24" rett R11 ■ **A11**

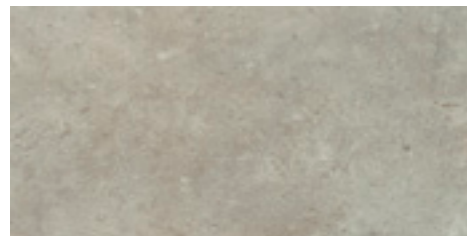

1067732 60x120 . 24"x48" rett ■ **A29**
1069844 60x120 . 24"x48" rett R11 ■ **A30**



1067733 60x120 . 24"x48" rett ■ **A29**
1069845 60x120 . 24"x48" rett R11 ■ **A30**

PROMENADE

Colours



Ebano



✂ 8,5 mm - 5/16"

1068034 100x100 . 40"x40" rett ■ **A32**

Sabbia

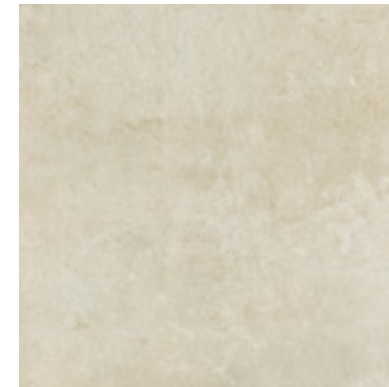

✂ 8,5 mm - 5/16"

1068035 100x100 . 40"x40" rett ■ **A32**



✂ 9,5 mm - 3/8"

1068374 120x120 . 48"x48" rett ■ **A44**

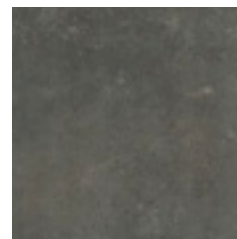

1067751 60x60 . 24"x24" rett ■ **A13**

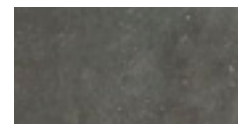

1069854 30x60 . 12"x24" rett ■ **A10**



✂ 9,5 mm - 3/8"

1068375 120x120 . 48"x48" rett ■ **A44**

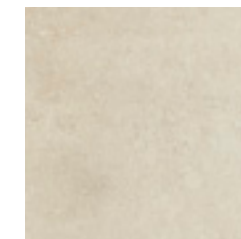

1067752 60x60 . 24"x24" rett ■ **A13**
1069849 60x60 . 24"x24" rett R11 ■ **A14**

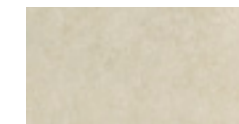

1069855 30x60 . 12"x24" rett ■ **A10**
1069859 30x60 . 12"x24" rett R11 ■ **A11**

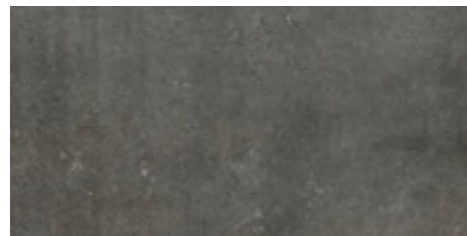

1067734 60x120 . 24"x48" rett ■ **A29**

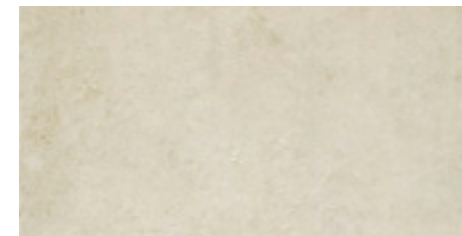

1067735 60x120 . 24"x48" rett ■ **A29**
1069846 60x120 . 24"x48" rett R11 ■ **A30**

PROMENADE

Colours



Tan



1068036 100x100 . 40"x40" rett ■ **A32**

✚ 8,5 mm - 5/16"



1068376 120x120 . 48"x48" rett ■ **A44**

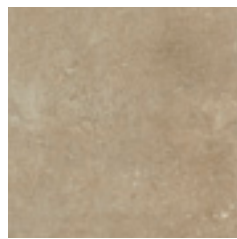

1067753 60x60 . 24"x24" rett ■ **A13**



1069856 30x60 . 12"x24" rett ■ **A10**

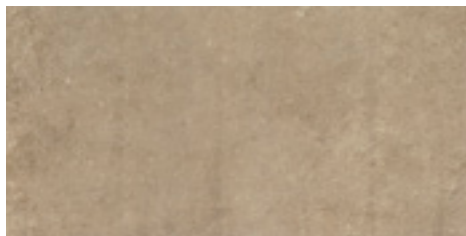

1067736 60x120 . 24"x48" rett ■ **A29**

✚ 9,5 mm - 3/8"

Mosaics ✚ 9,5 mm - 3/8"

30x30 - 12"x12"
Foglio. Sheet. Feuille. Blatt. Лист

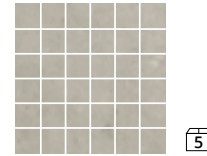

1070676 Mosaico
Argento tessera 5x5 . 2"x2"
rett ● **B13**



1070677 Mosaico
Corda tessera 5x5 . 2"x2"
rett ● **B13**

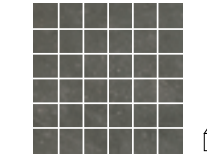

1070678 Mosaico
Ebano tessera 5x5 . 2"x2"
rett ● **B13**



1070679 Mosaico
Sabbia tessera 5x5 . 2"x2"
rett ● **B13**

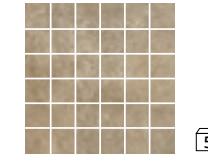

1070680 Mosaico
Tan tessera 5x5 . 2"x2"
rett ● **B13**

25x30 - 10"x12"
Foglio. Sheet. Feuille. Blatt. Лист

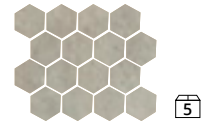

1070681 Mosaico
Esagona Argento
25x30 . 10"x12"
rett ● **B19**



1070682 Mosaico
Esagona Corda
25x30 . 10"x12"
rett ● **B19**



1070683 Mosaico
Esagona Ebano
25x30 . 10"x12"
rett ● **B19**

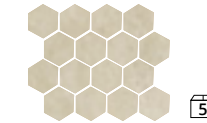

1070684 Mosaico
Esagona Sabbia
25x30 . 10"x12"
rett ● **B19**

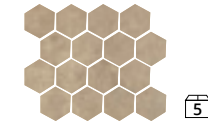

1070685 Mosaico
Esagona Tan
25x30 . 10"x12"
rett ● **B19**

24x40 - 9 7/16"x16"
Foglio. Sheet. Feuille. Blatt. Лист



1070686 Mosaico
Bricks Argento
24x40 . 9 7/16"x16"
rett ● **B14**



1070687 Mosaico
Bricks Corda
24x40 . 9 7/16"x16"
rett ● **B14**



1070688 Mosaico
Bricks Ebano
24x40 . 9 7/16"x16"
rett ● **B14**



1070689 Mosaico
Bricks Sabbia
24x40 . 9 7/16"x16"
rett ● **B14**



1070690 Mosaico
Bricks Tan
24x40 . 9 7/16"x16"
rett ● **B14**

PROMENADE

Trims \times 9,5 mm - $\frac{3}{8}$ "



Battiscopa
6,5x60 . 2 $\frac{9}{16}$ "x24" rett \blacktriangleright C5

- 1070696** Argento
- 1070697** Corda
- 1070698** Ebano
- 1070699** Sabbia
- 1070700** Tan

Elemento a "L" Assemblato
15x60x5 . 6"x24"x2" R11 rett \bullet B27

- 1070701** Argento
- 1070702** Corda
- 1070703** Sabbia



Gradone Costa Retta
30x120x3,3 . 12"x48"x1 $\frac{5}{16}$ " rett \bullet B51

- 1070704** Argento
- 1070705** Corda
- 1070706** Ebano
- 1070707** Sabbia
- 1070708** Tan

Gradone Square Assemblato
30x120x3,3 . 12"x48"x1 $\frac{5}{16}$ " rett \bullet B62

- 1070709** Argento
- 1070710** Corda
- 1070711** Ebano
- 1070712** Sabbia
- 1070713** Tan

\times 8,5 mm - $\frac{5}{16}$ "



Battiscopa
6,5x100 . 2 $\frac{9}{16}$ "x40" rett \blacktriangleright C7

- 1070691** Argento
- 1070692** Corda
- 1070693** Ebano
- 1070694** Sabbia
- 1070695** Tan

	BOX			PALLET		
	PZ	SQM	KGS	BOXES	SQM	KGS
100x100 . 40"x40" rett	2	2,00	38,00	24	48,00	950
120x120 . 48"x48" rett	1	1,44	31,00	40	57,60	1.300
60x120 . 24"x48" rett / R11	2	1,44	31,00	36	51,84	1.144
60x60 . 24"x24" rett / R11	3	1,08	22,80	40	43,20	928
30x60 . 12"x24" rett / R11	6	1,08	22,80	40	43,20	928
Battiscopa 6,5x60 . 2 $\frac{9}{16}$ "x24" rett	12	7,20 ml	11,00			
Battiscopa 6,5x100 . 2 $\frac{9}{16}$ "x40" rett	6	6,00 ml	9,00			
Elemento a "L" Assemblato R11 15x60x5 . 6"x24"x2" rett	4		11,00			
Gradone Costa Retta 30x120x3,3 . 12"x48"x1 $\frac{5}{16}$ " rett	4		34,00			
Gradone Square Assemblato 30x120x3,3 . 12"x48"x1 $\frac{5}{16}$ " rett	2		19,00			



concrete
& stone

Mosaico Esagona Sabbia 25x30 . 10"x12" rett / Battiscopa Sabbia 6,5x100 . 2 $\frac{9}{16}$ "x40" rett

2

metal



COSTRUIRE

architettura contemporanea

metal

GRES PORCELLANATO A TUTTA MASSA
 FULL BODY PORCELAIN STONEWARE
 GRÈS CÉRAMÉ PLAINE MASSE
 VOLLMASSEFEINSTEINZEUG
 КЕРАМОГРАНИТ ПО ВСЕЙ ТОЛЩИНЕ



Colours

Metallo Bianco



Metallo Nero

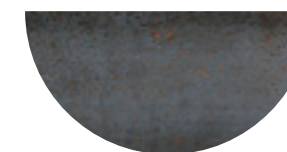

Metallo Ruggine



Metallo Titanio



Finishes

MATT



Sizes **➤ 8,5 mm - 5/16"**

80x180
32"x72"



100x100
40"x40"

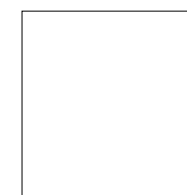

50x100
25"x40"



Sizes **➤ 9,5 mm - 3/8"**

60x120
24"x48"



30x120
12"x48"

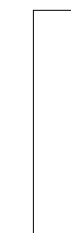

60x60
24"x24"



30x60
12"x24"

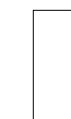



metal

Metallo Titanio 50x100 . 20"x40" rett / Mosaico Random Metallo Titanio 30x30 . 12"x12"
Wall16 Romeo and Juliet (comp. 2pz) 120x120 . 48"x48" rett (Collezione Showall vedi pag. 204)



Metallo Bianco 100x100 . 40"x40" rett
Wall16 Romeo and Juliet (comp. 2pz) 120x120 . 48"x48" rett (Collezione Showall vedi pag. 204)



metal

Metallo Ruggine 80x180 . 32"x72" rett



Metallo Strong Mix Nero 30x120 . 12"x48" / Metallo Nero 30x120 . 12"x48" rett / Metallo Bianco 80x180 . 32"x72" rett

COSTRUIRE

Colours



Metallo Bianco

✚ 8,5 mm - 5/16"



1062606
80x180 . 32"x72" rett ■ **A38**

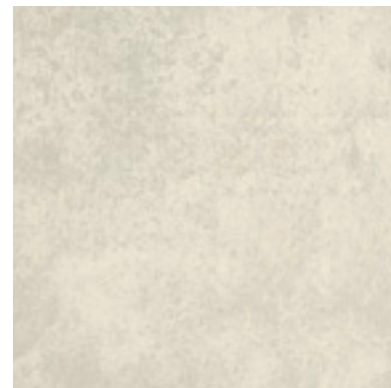

1062770
100x100 . 40"x40" rett ■ **A32**



1062801
50x100 . 20"x40" rett ■ **A28**

Metallo Nero

✚ 8,5 mm - 5/16"



1059793
80x180 . 32"x72" rett ■ **A38**



1060258
100x100 . 40"x40" rett ■ **A32**



1060308
50x100 . 20"x40" rett ■ **A28**

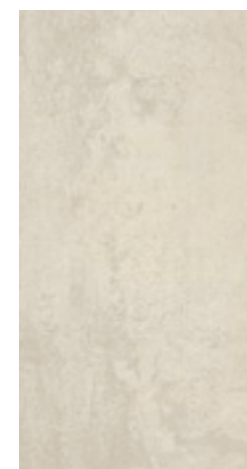

1062795
60x120 . 24"x48" rett ■ **A29**



1063159
30x120 . 12"x48" rett ■ **A31**



1062797
60x60 . 24"x24" rett ■ **A13**



1062799
30x60 . 12"x24" rett ■ **A10**

✚ 9,5 mm - 3/8"



1060319
60x120 . 24"x48" rett ■ **A29**



1063160
30x120 . 12"x48" rett ■ **A31**

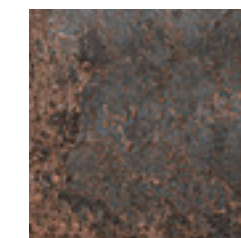

1060340
60x60 . 24"x24" rett ■ **A13**



1060348
30x60 . 12"x24" rett ■ **A10**

✚ 9,5 mm - 3/8"

COSTRUIRE

Colours



Metallo Ruggine

✂ 8,5 mm - 5/16"



1059794
80x180 . 32"x72" rett ■ **A38**



1060259
100x100 . 40"x40" rett ■ **A32**

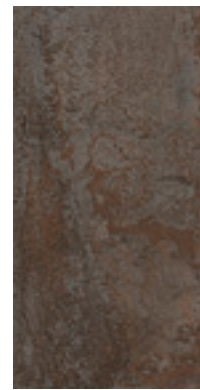

1060311
50x100 . 20"x40" rett ■ **A28**

Metallo Titanio

✂ 8,5 mm - 5/16"

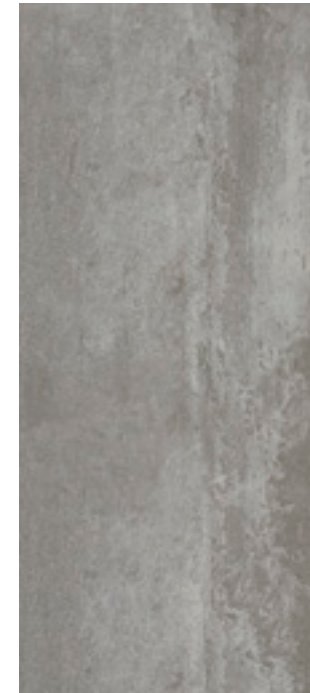

1059792
80x180 . 32"x72" rett ■ **A38**

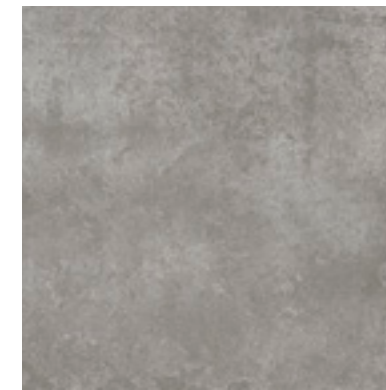

1060257
100x100 . 40"x40" rett ■ **A32**



1060305
50x100 . 20"x40" rett ■ **A28**

✂ 9,5 mm - 3/8"



1060320
60x120 . 24"x48" rett ■ **A29**



1063161
30x120 . 12"x48" rett ■ **A31**



1060341
60x60 . 24"x24" rett ■ **A13**



1060349
30x60 . 12"x24" rett ■ **A10**

✂ 9,5 mm - 3/8"



1060317
60x120 . 24"x48" rett ■ **A29**

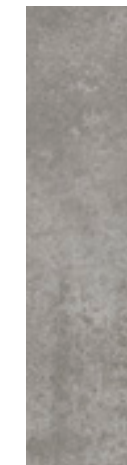

1063162
30x120 . 12"x48" rett ■ **A31**



1060339
60x60 . 24"x24" rett ■ **A13**

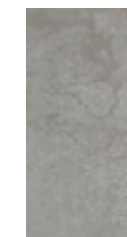

1060346
30x60 . 12"x24" rett ■ **A10**

COSTRUIRE

Colours



1063156 Metallo Strong Mix Bianco*
30x120 . 12"x48" rett **A39**

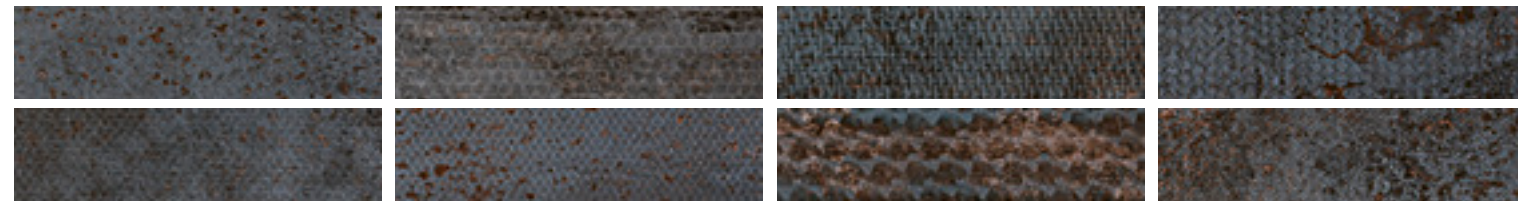

1062817 Metallo Strong Mix Nero*
30x120 . 12"x48" rett **A39**

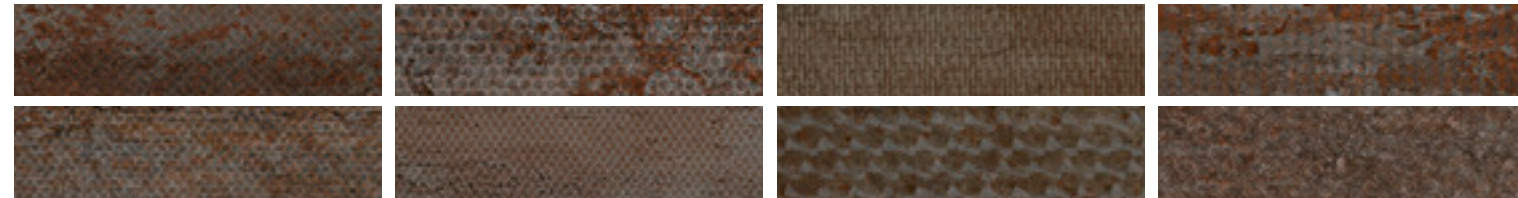

1062818 Metallo Strong Mix Ruggine*
30x120 . 12"x48" rett **A39**

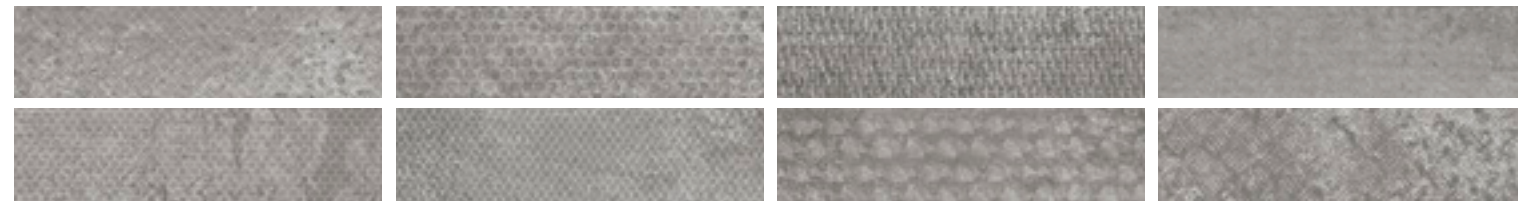

1063157 Metallo Strong Mix Titanio*
30x120 . 12"x48" rett **A39**

Mosaics $\pm 9,5 \text{ mm} - 3/8''$

30x30 - 12"x12"
Foglio. Sheet. Feuille. Blatt. Лист



1062370 Mosaico Metallo Bianco
tessera 5x5 . 2"x2" rett **B13**

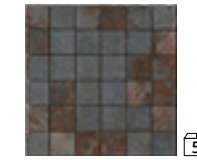

1062372 Mosaico Metallo Nero
tessera 5x5 . 2"x2" rett **B13**



1062373 Mosaico Metallo Ruggine
tessera 5x5 . 2"x2" rett **B13**



1062371 Mosaico Metallo Titanio
tessera 5x5 . 2"x2" rett **B13**



1062374 Mosaico Random Metallo Bianco **B22**



1062376 Mosaico Random Metallo Nero **B22**

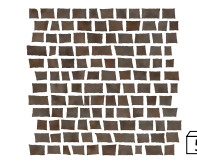

1062377 Mosaico Random Metallo Ruggine **B22**

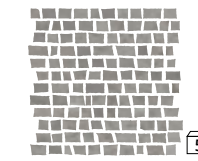

1062375 Mosaico Random Metallo Titanio **B22**

Decors* $\pm 8,5 \text{ mm} - 5/16''$

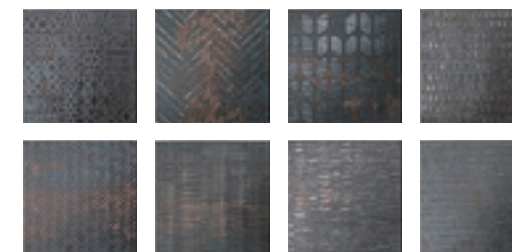

1062873 Lamiera Mix Nero S/8
25x25 . 10"x10" rett **B26**

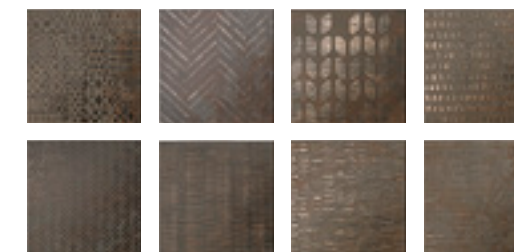

1062874 Lamiera Mix Ruggine S/8
25x25 . 10"x10" rett **B26**

* Soggetti miscelati casualmente nelle scatole. Designs available with each box containing a random mix.
Motifs mélangés au hasard dans les boîtes. Muster in den Schachteln werden nach den Zufallsprinzip gemischt. Вариантов, в коробке упакована произвольная смесь из них.

* Decori da rivestimento ad uso residenziale interno. Wall decorations for interior residential.
Décor mural pour usage résidentiel intérieur. Wanddekore nur für Innenbereich geeignet. Декоры для отделки стен жилых помещений.

COSTRUIRE

Trims  9,5 mm - 3/8"



Battiscopa
6,5x60 . 2⁹/₁₆"x24" rett ► C5
1062358 Metallo Bianco
1062360 Metallo Nero
1062361 Metallo Ruggine
1062359 Metallo Titanio

 8,5 mm - 5/16"



Battiscopa
6,5x100 . 2⁹/₁₆"x40" rett ► C7
1062353 Metallo Bianco
1062355 Metallo Nero
1062356 Metallo Ruggine
1062354 Metallo Titanio

	BOX			PALLET		
	PZ	SQM	KGS	BOXES	SQM	KGS
80x180 . 32"x72" rett	1	1,44	28,70	36	51,84	1.080
100x100 . 40"x40" rett	1	1,00	19,00	42	42,00	814
	2	2,00	34,00	24	48,00	950
50x100 . 20"x40" rett	2	1,00	19,00	42	42,00	840
60x120 . 24"x48" rett	2	1,44	31,00	36	51,84	1.144
30x120 . 12"x48" rett / strong	4	1,44	31,00	24	34,56	760
60x60 . 24"x24" rett	3	1,08	22,80	40	43,20	928
30x60 . 12"x24" rett	6	1,08	22,80	40	43,20	928
Battiscopa 6,5x60 . 2 ⁹ / ₁₆ "x24" rett	12	7,20 ml	11,00			
Battiscopa 6,5x100 . 2 ⁹ / ₁₆ "x40" rett	6	6,00 ml	7,50			



Metallo Nero 80x180 . 32"x72" rett / Lamiera Mix Nero S/8 25x25 . 10"x10" rett

3

- 100 I ROVERI
- 114 ÀCANTO
- 120 NORWAY
- 130 NEWPORT 2.0
- 136 CHARWOOD

wood



I ROVERI

essenza d'eleganza

wood

GRES PORCELLANATO SMALTATO COLORATO IN MASSA
 GLAZED PORCELAIN STONEWARE WITH COLOURED BODY
 GRÈS CÉRAME ÉMAILLÉ COLORÉ DANS LA MASSE
 GLASIERTES FEINSTEINZEUG IN DER MASSE GEFÄRBT
 ГЛАЗУРОВАННЫЙ КЕРАМОГРАНИТ, ОКРАШЕННЫЙ ПО ВСЕЙ ТООЛЩИНЕ



Colours

Rovere Antico



Rovere Decapè



Rovere Intenso



Rovere Naturale



Finishes

MATT



GRIP



Sizes ➤ 9,5 mm - 3/8"

30x120
12"x48"



20x120
8"x48"



10x40
4"x16"



CASSETTONE
60x60
24"x24"

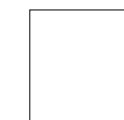

Rovere Intenso 10x40 . 4"x16" / Magistra Paonazetto 80x180 . 32"x72" lux-rett



Rovere Antico 20x120 . 8"x48" rett / Rovere Antico 30x120 . 12"x48" rett



Rovere Intenso 20x120 . 8"x48" R11 rett / Rovere Intenso 20x120 . 8"x48" rett



Rovere Decapè 10x40 . 4"x16"



wood

Rovere Naturale 20x120 . 8"x48" R11 rett / Pezzi speciali Rovere Naturale



Rovere Antico 20x120 . 8"x48" rett / Rovere Antico 30x120 . 12"x48" rett
Cassettone Rovere Antico 60x60 . 24"x24" rett



Rovere Naturale 20x120 . 8"x48" rett

wood

I ROVERI

Colours



Rovere Antico



1077597 30x120 . 12"x48" rett ■ A15



1077589 20x120 . 8"x48" rett ■ A17
1077593 20x120 . 8"x48" rett R11 ■ A18



1078542 10x40 . 4"x16" ■ A12



1079263 Cassettone Rovere Antico
60x60 . 24"x24" rett ■ A23

✂ 9,5 mm - 3/8"

Rovere Decapè



1077598 30x120 . 12"x48" rett ■ A15



1077590 20x120 . 8"x48" rett ■ A17



1078543 10x40 . 4"x16" ■ A12

Rovere Intenso



1077599 30x120 . 12"x48" rett ■ A15



1077591 20x120 . 8"x48" rett ■ A17
1077594 20x120 . 8"x48" rett R11 ■ A18



1078544 10x40 . 4"x16" ■ A12



1079264 Cassettone Rovere Intenso
60x60 . 24"x24" rett ■ A23

✂ 9,5 mm - 3/8"

Rovere Naturale



1077600 30x120 . 12"x48" ■ A15



1077592 20x120 . 8"x48" rett ■ A17
1077595 20x120 . 8"x48" rett R11 ■ A18



1078545 10x40 . 4"x16" ■ A12



1079265 Cassettone Rovere Naturale
60x60 . 24"x24" rett ■ A23

I ROVERI

Trims  9,5 mm - 3/8"



Battiscopa
7,5x120 . 3"x48" rett **C7**
1078468 Rovere Antico
1078469 Rovere Decapè
1078470 Rovere Intenso
1078471 Rovere Naturale

Gradone Costa Retta
30x120x3,3 . 12"x48"x1 5/16" rett **B51**
1078472 Rovere Antico
1078473 Rovere Decapè
1078474 Rovere Intenso
1078475 Rovere Naturale

	BOX			PALLET		
	PZ	SQM	KGS	BOXES	SQM	KGS
10x40 . 4"x16"	19	0,72	16,10	72	51,84	1.180
20x120 . 8"x48" rett / rett R11	4	0,96	20,70	48	46,08	1.022
30x120 . 12"x48" rett	4	1,44	31,00	24	34,56	760
60x60 . 24"x24" rett Cassettone	3	1,08	22,80	40	43,20	928
Battiscopa 7,5x120 . 3"x48" rett	6	7,20 ml	15,50			
Gradone Costa Retta 30x120x3,3 . 12"x48"x1 5/16" rett	4		34,00			



Cassettone Rovere Naturale 60x60 . 24"x24" rett



ÀCANTO

eterno charme

wood

GRES PORCELLANATO SMALTATO COLORATO IN MASSA
 GLAZED PORCELAIN STONEWARE WITH COLOURED BODY
 GRÈS CÉRAMÉ ÉMAILLÉ COLORÉ DANS LA MASSE
 GLASIERTES FEINSTEINZEUG IN DER MASSE GEFÄRBT
 ГЛАЗУРОВАННЫЙ КЕРАМОГРАНИТ, ОКРАШЕННЫЙ ПО ВСЕЙ ТООЛЩИНЕ



Colours

Bianco



Grigio



Miele



Noce



Rovere



Finishes

MATT



Sizes ✂ 9,5 mm - 3/8"

30x120
12"x48"



20x120
8"x48"





Grigio 30x120 . 12"x48" rett / Wall02 Myfair White 60x120 . 24"x48" (Collezione Showall vedi pag. 204)



wood

Rovere 30x120 . 12"x48" rett / Rovere 20x120 . 8"x48" rett

ÀCANTO

Colours



Bianco



1047706 30x120 . 12"x48" rett ■ **A15**



1047427 20x120 . 8"x48" rett ■ **A17**

Miele



1047708 30x120 . 12"x48" rett ■ **A15**



1047429 20x120 . 8"x48" rett ■ **A17**

Rovere



1047710 30x120 . 12"x48" rett ■ **A15**



1047431 20x120 . 8"x48" rett ■ **A17**

Grigio

✂ 9,5 mm - 3/8"



1047707 30x120 . 12"x48" rett ■ **A15**



1047428 20x120 . 8"x48" rett ■ **A17**

Noce



1047709 30x120 . 12"x48" rett ■ **A15**



1047430 20x120 . 8"x48" rett ■ **A17**

Mosaics ✂ 9,5 mm - 3/8"

30x30 - 12"x12"
Foglio. Sheet. Feuille. Blatt. Лист



1048070 Mosaico Àcanto Bianco tessera 5x5 . 2"x2" rett ● **B13**

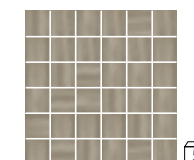

1048072 Mosaico Àcanto Grigio tessera 5x5 . 2"x2" rett ● **B13**

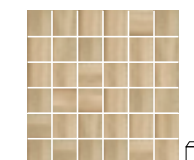

1048073 Mosaico Àcanto Miele tessera 5x5 . 2"x2" rett ● **B13**

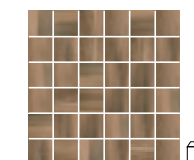

1048074 Mosaico Àcanto Noce tessera 5x5 . 2"x2" rett ● **B13**

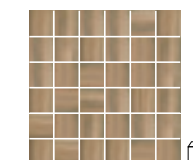

1048075 Mosaico Àcanto Rovere tessera 5x5 . 2"x2" rett ● **B13**

20x60 - 8"x24"
Foglio. Sheet. Feuille. Blatt. Лист



1048078 Mosaico Bricks Bianco 20x60 . 8"x24" rett ● **B22**



1048079 Mosaico Bricks Grigio 20x60 . 8"x24" rett ● **B22**



1048080 Mosaico Bricks Miele 20x60 . 8"x24" rett ● **B22**



1048081 Mosaico Bricks Noce 20x60 . 8"x24" rett ● **B22**



1048082 Mosaico Bricks Rovere 20x60 . 8"x24" rett ● **B22**

Trims ✂ 9,5 mm - 3/8"



Battiscopa
9,8x120 . 3 7/8"x48" rett ► **C7**
1048044 Àcanto Bianco
1048045 Àcanto Grigio
1048046 Àcanto Miele
1048047 Àcanto Noce
1048048 Àcanto Rovere



Gradone Costa Retta
30x120x3,3 - 12"x48"x1 5/16" rett ● **B51**
1063186 Àcanto Bianco
1063187 Àcanto Grigio
1062395 Àcanto Miele
1063188 Àcanto Noce
1063189 Àcanto Rovere

	BOX			PALLET		
	PZ	SQM	KGS	BOXES	SQM	KGS
20x120 . 8"x48" rett	4	0,96	20,70	48	46,08	1.022
30x120 . 12"x48" rett	4	1,44	31,00	24	34,56	760
Battiscopa 9,8x120 . 3 7/8"x48" rett	6	7,20 ml	15,50			
Gradone Costa Retta 30x120x3,3 . 12"x48"x1 5/16" rett	4		34,00			



NORWAY

north wood

wood

GRES FINE PORCELLANATO SMALTATO

GLAZED FINE PORCELAIN STONEWAREE
GRÈS CÉRAME FIN ÉMAILLÉ
GLASIERTES FEINSTEINZEUG
ГЛАЗУРОВАННЫЙ КЕРАМОГРАНИТ



Colours

Beautiful Shade



Golden Sunset



Long Night



Natural Feeling

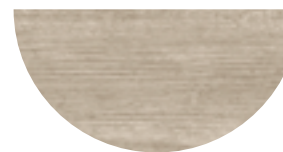

Nordic Land



Norway Mix Cold



Finishes

MATT



Sizes  9,5 mm - 3/8"

30x120
12"x48"



20x120
8"x48"





wood

Golden Sunset 20x120 . 8"x48" rett



Long Night 20x120 . 8"x48" rett / 30x120 . 12"x48" rett



wood

Natural Feeling 20x120 . 8"x48" rett



Beautiful Shade 20x120 . 8"x48" rett / 30x120 . 12"x48" rett
Wall07 White Leaf (comp. 2pz) 120x120 . 48"x48" rett (Collezione Showall vedi pag. 204)

NORWAY

Colours



Beautiful Shade



1050644 30x120 . 12"x48" rett ■ **A15**



1050638 20x120 . 8"x48" rett ■ **A17**

Long Night



1050646 30x120 . 12"x48" rett ■ **A15**

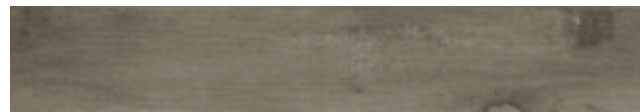

1050640 20x120 . 8"x48" rett ■ **A17**

Nordic Land



1050648 30x120 . 12"x48" rett ■ **A15**

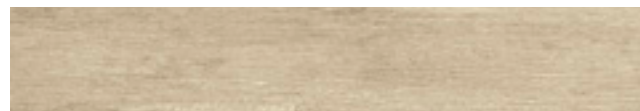

1050642 20x120 . 8"x48" rett ■ **A17**

Golden Sunset

✂ 9,5 mm - 3/8"

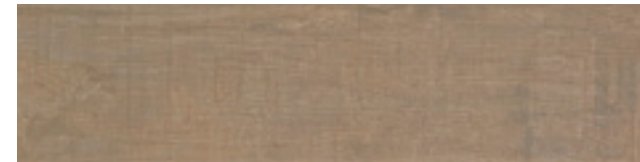

1050645 30x120 . 12"x48" rett ■ **A15**



1050639 20x120 . 8"x48" rett ■ **A17**

Natural Feeling



1050647 30x120 . 12"x48" rett ■ **A15**



1050641 20x120 . 8"x48" rett ■ **A17**

Norway Mix Cold



1050643 20x120 . 8"x48" rett ■ **A18**

Mosaics ✂ 9,5 mm - 3/8"

30x30 - 12"x12"
Foglio. Sheet. Feuille. Blatt. Лист



1050914 Mosaico Beautiful Shade tessera 5x5 . 2"x2" rett ● **B13**



1050915 Mosaico Golden Sunset tessera 5x5 . 2"x2" rett ● **B13**



1050916 Mosaico Long Night tessera 5x5 . 2"x2" rett ● **B13**



1050917 Mosaico Natural Feeling tessera 5x5 . 2"x2" rett ● **B13**



1050918 Mosaico Nordic Land tessera 5x5 . 2"x2" rett ● **B13**



1052879 Mosaico Intreccio Cold (Long Night - Natural Feeling) (11,5 pz al mq) ● **B29**



1052880 Mosaico Intreccio Warm (Beautiful Shade - Golden Sunset) (11,5 pz al mq) ● **B29**

Trims ✂ 9,5 mm - 3/8"



Battiscopa
7,5x120 . 3"x48" rett ► **C7**
1050739 Beautiful Shade
1050740 Golden Sunset
1050741 Long Night
1050742 Natural Feeling
1050893 Nordic Land



Gradone Costa Retta
30x120x3,3 - 12"x48"x1 5/16" rett ● **B51**
1059987 Beautiful Shade
1063182 Golden Sunset
1063183 Long Night
1063184 Natural Feeling
1063185 Nordic Land

	BOX			PALLET		
	PZ	SQM	KGS	BOXES	SQM	KGS
20x120 . 8"x48" rett	4	0,96	20,70	48	46,08	1.022
30x120 . 12"x48" rett	4	1,44	31,00	24	34,56	760
Battiscopa 7,5x120 . 3"x48" rett	6	7,20 ml	12,00			
Gradone Costa Retta 30x120x3,3 . 12"x48"x1 5/16" rett	4		34,00			



NEWPORT 2.0

unconventional wood

wood

GRES FINE PORCELLANATO SMALTATO
 GLAZED FINE PORCELAIN STONEWAREE
 GRÈS CÉRAME FIN ÉMAILLÉ
 GLASIERTES FEINSTEINZEUG
 ГЛАЗУРОВАННЫЙ КЕРАМОГРАНИТ



Colours

New Ash



New Birch



New Fir



New Maple



Finishes

MATT



Sizes **↕** 9,5 mm - 3/8"

30x120
12"x48"



20x120
8"x48"

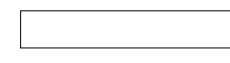

New Fir 20x120 . 8"x48" rett / 30x120 . 12"x48" rett



New Maple 20x120 . 8"x48" rett



wood

New Fir 20x120 . 8"x48" rett / 30x120 . 12"x48" rett

NEWPORT 2.0

Colours



New Ash



1055725 30x120 . 12"x48" rett ■ **A15**



1055720 20x120 . 8"x48" rett ■ **A17**

New Fir



1055833 30x120 . 12"x48" rett ■ **A15**



1055832 20x120 . 8"x48" rett ■ **A17**

New Birch

✂ 9,5 mm - 3/8"



1055726 30x120 . 12"x48" rett ■ **A15**



1055721 20x120 . 8"x48" rett ■ **A17**

New Maple



1055728 30x120 . 12"x48" rett ■ **A15**



1055723 20x120 . 8"x48" rett ■ **A17**

Trims ✂ 9,5 mm - 3/8"



Battiscopa
7,5x120 - 3"x48" rett ► **C7**
1055791 New Ash
1055792 New Birch
1055834 New Fir
1055794 New Maple



Gradone Costa Retta
30x120x3,3 - 12"x48"x1 5/16" rett ● **B51**
1063171 New Ash
1063172 New Birch
1063174 New Fir
1063175 New Maple



wood

New Birch 20x120 . 8"x48" rett / 30x120 . 12"x48" rett

	BOX			PALLET		
	PZ	SQM	KGS	BOXES	SQM	KGS
20x120 . 8"x48" rett	4	0,96	20,70	48	46,08	1.022
30x120 . 12"x48" rett	4	1,44	31,00	24	34,56	760
Battiscopa 7,5x120 . 3"x48" rett	6	7,20 ml	12,00			
Gradone Costa Retta 30x120x3,3 . 12"x48"x1 5/16" rett	4		34,00			



CHARWOOD

profondità d'essenza

wood

GRES PORCELLANATO SMALTATO
GLAZED PORCELAIN STONEWARE
GRÈS CÉRAME ÉMAILLÉ
GLASIERTES FEINSTEINZEUG
ГЛАЗУРОВАННЫЙ КЕРАМОГРАНИТ



Colours

Ash



Burned



Carbon



Finishes

MATT



✂ 10 mm - 3/8"

18x118
7 1/16" x 46 7/16"

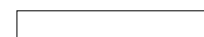



Carbon 18x118 . 7 1/16" x 46 7/16"



wood

Ash 18x118 . 7 1/16" x 46 7/16" / Mosaico Spinetta Ash 31x31 . 12 3/16" x 12 3/16"

CHARWOOD

Colours



Ash



1058434 18x118 . 7 1/16"x46 7/16" ■ A11

10 mm - 3/8"

Burned



1058437 18x118 . 7 1/16"x46 7/16" ■ A11

Carbon

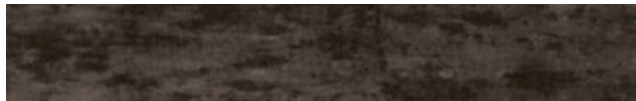

1058438 18x118 . 7 1/16"x46 7/16" ■ A11

Mosaics 10 mm - 3/8"

30x30 - 12"x12"
Foglio. Sheet. Feuille. Blatt. Лист

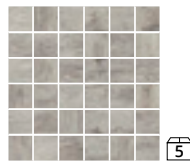

1059029 Mosaico Ash tessera 5x5 . 2"x2" ● B13

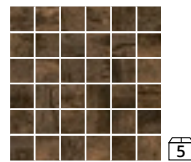

1059030 Mosaico Burned tessera 5x5 . 2"x2" ● B13

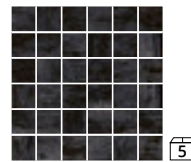

1059031 Mosaico Carbon tessera 5x5 . 2"x2" ● B13

Mosaics 10 mm - 3/8"

31x31 - 12 3/16"x12 3/16"
Foglio. Sheet. Feuille. Blatt. Лист



1059032 Mosaico Spinetta Ash 31x31 . 12 3/16"x 12 3/16" ● B18



1059033 Mosaico Spinetta Burned 31x31 . 12 3/16"x 12 3/16" ● B18



1059034 Mosaico Spinetta Carbon 31x31 . 12 3/16"x 12 3/16" ● B18

Trims 10 mm - 3/8"



Battiscopa 9x118 - 3 9/16"x46 7/16" ► C7
1059035 Ash
1059036 Burned
1059037 Carbon



Gradone Costa Retta (comp. 2 pz) 36x118x3,3 - 14 3/16"x46 7/16"x1 5/16" ● B50
1059038 Ash
1059039 Burned
1059040 Carbon

	BOX			PALLET		
	PZ	SQM	KGS	BOXES	SQM	KGS
18x118 . 7 1/16"x46 7/16"	5	1,06	21,50	36	38,16	790
Battiscopa 9,8x118 . 3 9/16"x46 7/16"	6	7,08 ml	14,50			
Gradone Costa Retta 36x118x3,3 . 14 3/16"x46 7/16"x1 5/16"	comp 2		24,00			

4

- 114 TRAVERTINI DUE
- 154 GEMME
- 166 MAGISTRA
- 176 FOSSIL
- 190 DUOMO

marble



TRAVERTINI DUE

seducente perfezione

marble

GRES PORCELLANATO SMALTATO COLORATO IN MASSA
 GLAZED PORCELAIN STONEWARE WITH COLOURED BODY
 GRÈS CÉRAME ÉMAILLÉ COLORÉ DANS LA MASSE
 GLASIERTES FEINSTEINZEUG IN DER MASSE GEFÄRBT
 ГЛАЗУРОВАННЫЙ КЕРАМОГРАНИТ, ОКРАШЕННЫЙ ПО ВСЕЙ ТООЛЩИНЕ



Colours

Beige



Bianco



Greige



Finishes

LUX



MATT



Sizes ∇ 8,5 mm - $\frac{5}{16}$ "

100x100
40"x40"

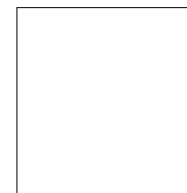

∇ 9,5 mm - $\frac{3}{8}$ "

60x120
24"x48"



60x60
24"x24"

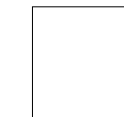

30x60
12"x24"



Greige 60x120 . 24"x48" rett / Mosaico Legno Greige 20x120 . 8"x48" lux-rett



marble

Greige 60x120 . 24"x48" rett / pezzi speciali Greige rett
Wall20 - Fontana 60x120 . 24"x48" rett (Collezione Showall vedi pag. 204)
Wall21 - Mondrian 60x120 . 24"x48" rett (Collezione Showall vedi pag. 204)



Bianco 60x60 . 24"x24" rett / Mosaico Bianco 5x5 . 2"x2" rett
Wall20 - Fontana 60x120 . 24"x48" rett (Collezione Showall vedi pag. 204)



marble

Bianco 60x120 . 24"x48" lux-rett / Mosaico Legno Bianco 20x120 . 8"x48" lux-rett

TRAVERTINI DUE

marble

Colours

Beige



1073526 100x100 . 40"x40" rett ■ **A32**
1073525 100x100 . 40"x40" lux-rett ■ **A44**

Bianco

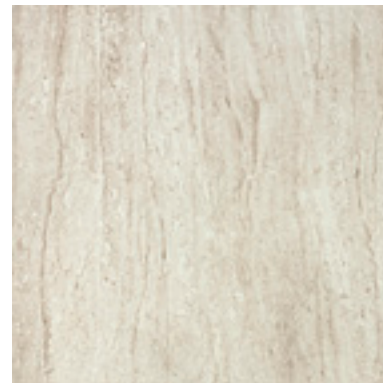

✂ 8,5 mm - 5/16"

1073528 100x100 . 40"x40" rett ■ **A32**
1073527 100x100 . 40"x40" lux-rett ■ **A44**

Greige



✂ 8,5 mm - 5/16"

1073530 100x100 . 40"x40" rett ■ **A32**
1073529 100x100 . 40"x40" lux-rett ■ **A44**

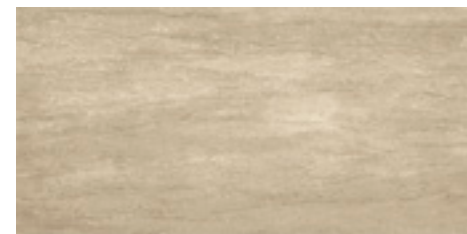

1072921 60x120 . 24"x48" rett ■ **A29**
1072941 60x120 . 24"x48" lux-rett ■ **A42**



✂ 9,5 mm - 3/8"

1072920 60x120 . 24"x48" rett ■ **A29**
1072940 60x120 . 24"x48" lux-rett ■ **A42**



✂ 9,5 mm - 3/8"

1072922 60x120 . 24"x48" rett ■ **A29**
1072942 60x120 . 24"x48" lux-rett ■ **A42**



1073744 60x60 . 24"x24" rett ■ **A13**
1073745 60x60 . 24"x24" lux-rett ■ **A31**



1074394 30x60 . 12"x24" rett ■ **A10**
1074391 30x60 . 12"x24" lux-rett ■ **A27**

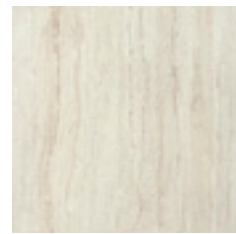

1074389 60x60 . 24"x24" rett ■ **A13**
1074387 60x60 . 24"x24" lux-rett ■ **A31**



1074395 30x60 . 12"x24" rett ■ **A10**
1074392 30x60 . 12"x24" lux-rett ■ **A27**



1074390 60x60 . 24"x24" rett ■ **A13**
1074388 60x60 . 24"x24" lux-rett ■ **A31**



1074396 30x60 . 12"x24" rett ■ **A10**
1074393 30x60 . 12"x24" lux-rett ■ **A27**

Mosaics ✂ 9,5 mm - 3/8"

30x30 - 12"x12"
Foglio. Sheet. Feuille. Blatt. Лист

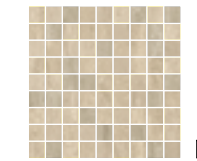

1074329 Mosaico Beige tessera 3x3 . 1¹³/₁₆"x1¹³/₁₆" lux-rett ■ **B19**



1074330 Mosaico Bianco tessera 3x3 . 1¹³/₁₆"x1¹³/₁₆" lux-rett ■ **B19**

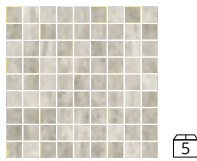

1074331 Mosaico Greige tessera 3x3 . 1¹³/₁₆"x1¹³/₁₆" lux-rett ■ **B19**

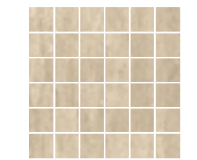

1074326 Mosaico Beige tessera 5x5 . 2"x2" rett ■ **B14**



1074327 Mosaico Bianco tessera 5x5 . 2"x2" rett ■ **B14**

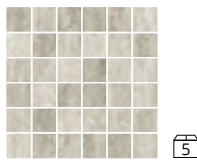

1074328 Mosaico Greige tessera 5x5 . 2"x2" rett ■ **B14**

20x120 - 8"x48"
Foglio. Sheet. Feuille. Blatt. Лист



1074927 Mosaico Legno Beige 20x120 . 8"x48" lux-rett ■ **B33**



1074928 Mosaico Legno Bianco 20x120 . 8"x48" lux-rett ■ **B33**

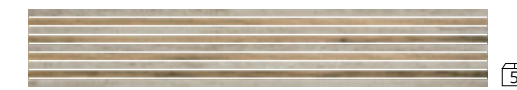

1074929 Mosaico Legno Greige 20x120 . 8"x48" lux-rett ■ **B33**

TRAVERTINI DUE

Trims  9,5 mm - 3/8"



Battiscopa
6,5x60 . 2 9/16"x24" rett ► **C5**

- 1074341** Beige
- 1074342** Bianco
- 1074343** Greige

Battiscopa
6,5x60 . 2 9/16"x24" lux-rett ► **C6**

- 1074338** Beige
- 1074339** Bianco
- 1074340** Greige

 8,5 mm - 5/16"



Battiscopa
6,5x100 . 2 9/16"x40" rett ► **C7**

- 1074335** Beige
- 1074336** Bianco
- 1074337** Greige

Battiscopa
6,5x100 . 2 9/16"x40" lux-rett ► **C8**

- 1074332** Beige
- 1074333** Bianco
- 1074334** Greige

	BOX			PALLET		
	PZ	SQM	KGS	BOXES	SQM	KGS
100x100 . 40"x40" rett / lux-rett	1	1,00	19,00	42	42,00	814
	2	2,00	38,00	24	48,00	950
60x120 . 24"x48" lux-rett	2	1,44	32,00	36	51,84	1.190
60x120 . 24"x48" rett	2	1,44	31,00	36	51,84	1.144
60x60 . 24"x24" lux-rett	3	1,08	23,00	40	43,20	936
60x60 . 24"x24" rett	3	1,08	22,80	40	43,20	928
30x60 . 12"x24" lux-rett	6	1,08	23,00	40	43,20	936
30x60 . 12"x24" rett	6	1,08	22,80	40	43,20	928
Battiscopa 6,5x60 . 2 9/16"x24" rett / lux-rett	12	7,20 ml	11,00			
Battiscopa 6,5x100 . 2 9/16"x40" rett / lux-rett	6	6,00 ml	9,00			

Beige 60x120 . 24"x48" rett , 60x120 . 24"x48" lux-rett / Mosaico Legno Beige 20x120 . 8"x48" lux-rett





GEMME

preziosa concretezza

marble

GRES FINE PORCELLANATO SMALTATO
 GLAZED FINE PORCELAIN STONEWAREE
 GRÈS CÉRAME FIN ÉMAILLÉ
 GLASIERTES FEINSTEINZEUG
 ГЛАЗУРОВАННЫЙ КЕРАМОГРАНИТ



Colours

Breccia Sabbia



Black Mirror



Colorado



Daino



Saturnia

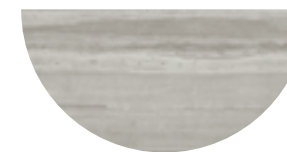

Finishes

LUX



Sizes $\pm 8,5 \text{ mm} - \frac{5}{16}''$

80x180
32"x72"



100x100
40"x40"



50x100
20"x40"

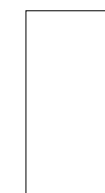

$\pm 9,5 \text{ mm} - \frac{3}{8}''$

60x120
24"x48"

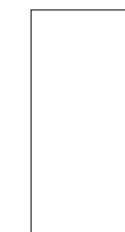

60x60
24"x24"

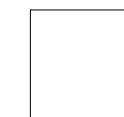

30x60
12"x24"



Black Mirror 100x100 . 40"x40" lux-rett / Colorado 100x100 . 40"x40" lux-rett



Daino 100x100 . 40"x40" lux-rett



Breccia Sabbia 100x100 . 40"x40" lux-rett

GEMME

Colours



Breccia Sabbia

✂ 8,5 mm - 5/16"

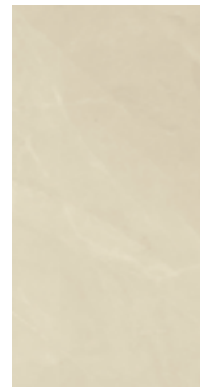
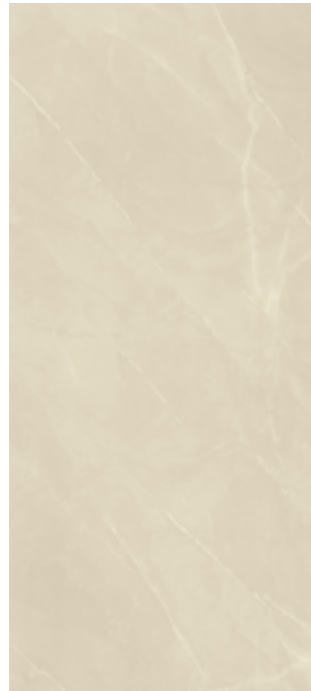

1059774 80x180 . 32"x72"
lux-rett ■ **A48**

1060026 100x100 . 40"x40"
lux-rett ■ **A44**

1060024 50x100 . 20"x40"
lux-rett ■ **A40**

Black Mirror

✂ 8,5 mm - 5/16"

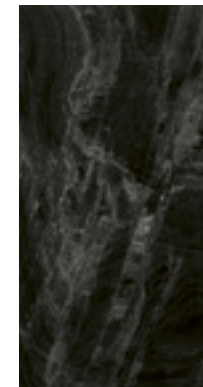
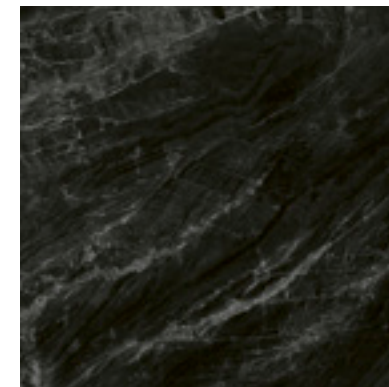
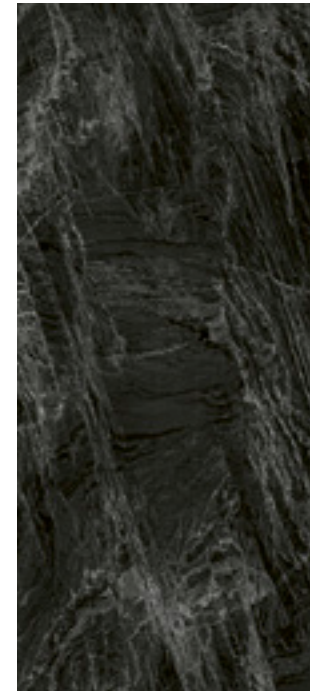

1059772 80x180 . 32"x72"
lux-rett ■ **A48**

1059449 100x100 . 40"x40"
lux-rett ■ **A44**

1059457 50x100 . 20"x40"
lux-rett ■ **A40**

✂ 9,5 mm - 3/8"

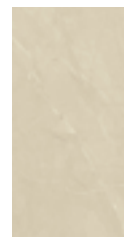
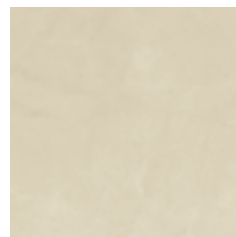
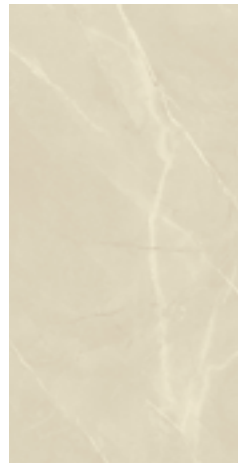

1060036 60x120 . 24"x48"
lux-rett ■ **A42**

1060040 60x60 . 24"x24"
lux-rett ■ **A31**

1060044 30x60 . 12"x24"
lux-rett ■ **A27**

✂ 9,5 mm - 3/8"

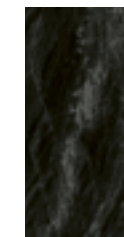
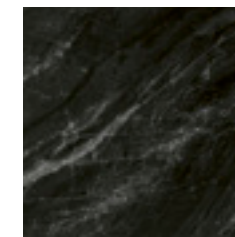
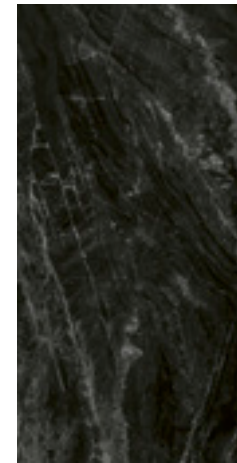

1058940 60x120 . 24"x48"
lux-rett ■ **A42**

1058952 60x60 . 24"x24"
lux-rett ■ **A31**

1058964 30x60 . 12"x24"
lux-rett ■ **A27**

GEMME

Colours



Colorado

✚ 8,5 mm - 5/16"



1059775 80x180 . 32"x72"
lux-rett ■ **A48**

1059450 100x100 . 40"x40"
lux-rett ■ **A44**

1059458 50x100 . 20"x40"
lux-rett ■ **A40**

Daino

✚ 8,5 mm - 5/16"

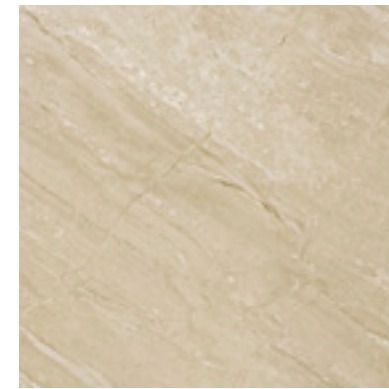

1059776 80x180 . 32"x72"
lux-rett ■ **A48**

1059451 100x100 . 40"x40"
lux-rett ■ **A44**

✚ 9,5 mm - 3/8"

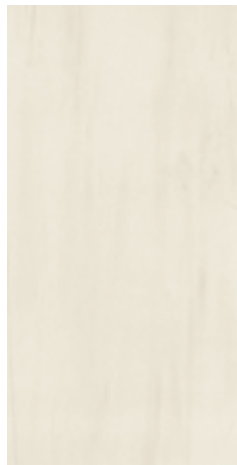

1058941 60x120 . 24"x48"
lux-rett ■ **A42**

1058953 60x60 . 24"x24"
lux-rett ■ **A31**

1058965 30x60 . 12"x24"
lux-rett ■ **A27**

✚ 9,5 mm - 3/8"

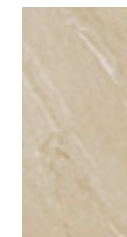
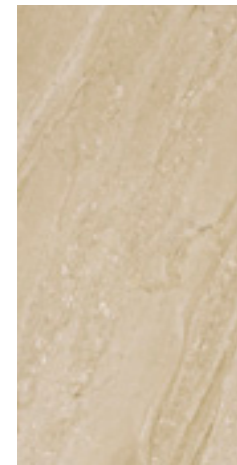

1058942 60x120 . 24"x48"
lux-rett ■ **A42**

1058954 60x60 . 24"x24"
lux-rett ■ **A31**

1058966 30x60 . 12"x24"
lux-rett ■ **A27**

GEMME

marble

Colours



Saturnia



1059778 80x180 . 32"x72"
lux-rett ■ **A48**



1059528 100x100 . 40"x40"
lux-rett ■ **A44**

✂ 8,5 mm - 5/16"



1058944 60x120 . 24"x48"
lux-rett ■ **A42**



1058956 60x60 . 24"x24"
lux-rett ■ **A31**



1058968 30x60 . 12"x24"
lux-rett ■ **A27**

✂ 9,5 mm - 3/8"

Mosaics ✂ 9,5 mm - 3/8"

30x30 - 12"x12"
Foglio. Sheet. Feuille. Blatt. Лист

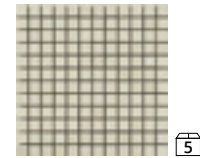

1059864 Mosaico Breccia Sabbia
tessera 2,2x2,2 . 7/8"x7/8"
lux-rett ● **B19**

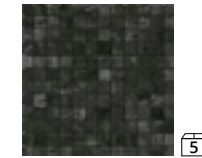

1059862 Mosaico Black Mirror
tessera 2,2x2,2 . 7/8"x7/8"
lux-rett ● **B19**

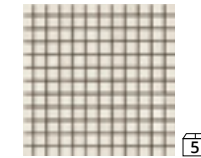

1059865 Mosaico Colorado
tessera 2,2x2,2 . 7/8"x7/8"
lux-rett ● **B19**

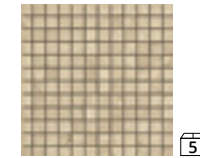

1059866 Mosaico Daino
tessera 2,2x2,2 . 7/8"x7/8"
lux-rett ● **B19**

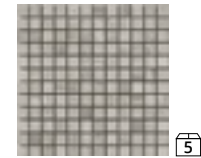

1059868 Mosaico Saturnia
tessera 2,2x2,2 . 7/8"x7/8"
lux-rett ● **B19**

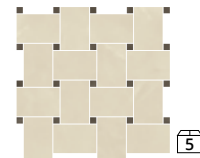

1059874 Mosaico Basket
Breccia Sabbia/Fossena
30x30 - 12"x12"
lux-rett ● **B18**

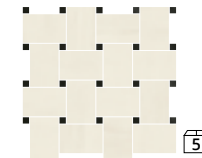

1059870 Mosaico Basket
Colorado/Black Mirror
30x30 - 12"x12"
lux-rett ● **B18**

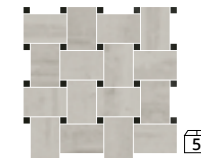

1059878 Mosaico Basket
Saturnia/Black Mirror
30x30 - 12"x12"
lux-rett ● **B18**

Decors* ✂ 8,5 mm - 5/16"

Heritage



1060496 Heritage Breccia Sabbia
50x100 . 20"x40" lux-rett ● **B58**

Texture



1060500 Texture Colorado
50x100 . 20"x40" lux-rett ● **B62**



1060917 Alzata Breccia Sabbia
15x40 . 6"x16"
lux-rett ● **B28**



1061570 Alzata Black Mirror
15x40 . 6"x16"
lux-rett ● **B28**



1061575 Alzata Colorado
15x40 . 6"x16"
lux-rett ● **B28**



1061577 Alzata Daino
15x40 . 6"x16"
lux-rett ● **B28**



1061580 Alzata Saturnia
15x40 . 6"x16"
lux-rett ● **B28**

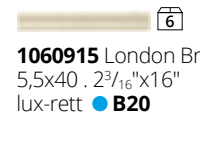

1060915 London Breccia Sabbia
5,5x40 . 2 3/16"x16"
lux-rett ● **B20**

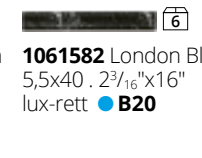

1061582 London Black Mirror
5,5x40 . 2 3/16"x16"
lux-rett ● **B20**

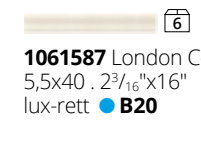

1061587 London Colorado
5,5x40 . 2 3/16"x16"
lux-rett ● **B20**



1061590 London Daino
5,5x40 . 2 3/16"x16"
lux-rett ● **B20**

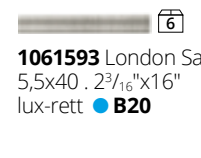

1061593 London Saturnia
5,5x40 . 2 3/16"x16"
lux-rett ● **B20**

* Decori da rivestimento ad uso residenziale interno.

Wall decorations for interior residential. Décor mural pour usage résidentiel intérieur. Wanddekore nur für Innenbereich geeignet. Декоры для отделки стен жилых помещений.

GEMME

Trims \times 9,5 mm - $\frac{3}{8}$ "



Battiscopa
6,5x60 . 2 $\frac{9}{16}$ "x24" lux-rett **C6**

- 1060528** Breccia Sabbia
- 1060524** Black Mirror
- 1060530** Colorado
- 1060532** Daino
- 1060536** Saturnia

\times 8,5 mm - $\frac{5}{16}$ "



Battiscopa
6,5x100 . 2 $\frac{9}{16}$ "x40" lux-rett **C8**

- 1060518** Breccia Sabbia
- 1060516** Black Mirror
- 1060520** Colorado
- 1060521** Daino
- 1060523** Saturnia

	BOX			PALLET		
	PZ	SQM	KGS	BOXES	SQM	KGS
80x180 . 32"x72" lux-rett	1	1,44	29,30	36	51,84	1.100
100x100 . 40"x40" lux-rett	1	1,00	19,00	42	42,00	814
	2	2,00	38,00	24	48,00	950
50x100 . 20"x40" lux-rett	2	1,00	19,00	42	42,00	840
60x120 . 24"x48" lux-rett	2	1,44	32,00	36	51,84	1.190
60x60 . 24"x24" lux-rett	3	1,08	23,00	40	43,20	936
30x60 . 12"x24" lux-rett	6	1,08	23,00	40	43,20	936
Battiscopa 6,5x60 . 2 $\frac{9}{16}$ "x24" lux-rett	12	7,20 ml	11,00			
Battiscopa 6,5x100 . 2 $\frac{9}{16}$ "x40" lux-rett	6	6,00 ml	7,50			



marble

Saturnia 60x120 . 24"x48" lux-rett / Mosaico Basket Saturnia/Black Mirror 30x30 . 12"x12" lux-rett
Elements Black Mirror lux-rett



MAGISTRA

dettagli d'autore

marble

GRES FINE PORCELLANATO SMALTATO
 GLAZED FINE PORCELAIN STONEWAREE
 GRÈS CÉRAME FIN ÉMAILLÉ
 GLASIERTES FEINSTEINZEUG
 ГЛАЗУРОВАННЫЙ КЕРАМОГРАНИТ



Colours

Cappuccino



Corinthian



Fior Di Bosco



Marquinia



Paonazetto



Finishes

LUX



Sizes ∇ 8,5 mm - $\frac{5}{16}$ "

∇ 9,5 mm - $\frac{3}{8}$ "

80x180
32"x72"



100x100
40"x40"

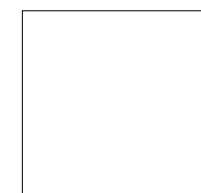

60x120
24"x48"

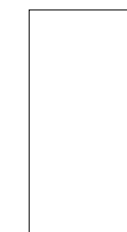

60x60
24"x24"

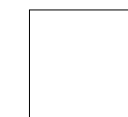

30x60
12"x24"



Paonazetto 100x100 . 40"x40" lux-rett / Marquinia 100x100 . 40"x40" lux-rett



marble

Cappuccino 80x180 . 32"x72" lux-rett / Marquinia 60x120 . 24"x48" lux-rett



Paonazetto 100x100 . 40"x40" lux-rett / Marquinia 100x100 . 40"x40" lux-rett
Wall06 Black Leaf (comp. 2pz) 120x120 . 48"x48" rett (Collezione Showall vedi pag. 204)



marble

Fior di Bosco 80x180 . 32"x72" lux-rett

MAGISTRA

Colours



Cappuccino

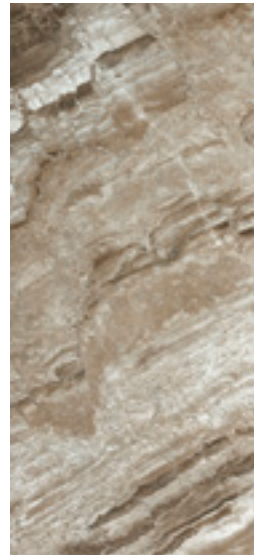

1062860
80x180 . 32"x72"
lux-rett ■ **A48**

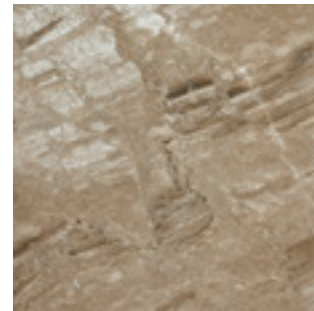

1063770
100x100 . 40"x40"
lux-rett ■ **A44**

Corinthian

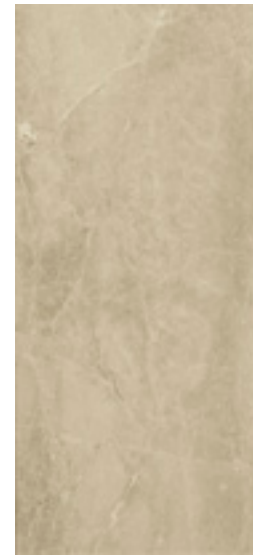

1062861
80x180 . 32"x72"
lux-rett ■ **A48**

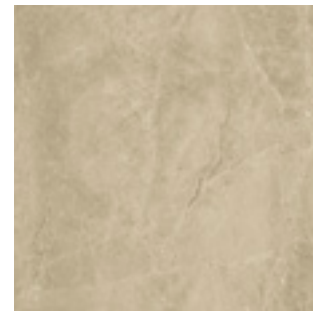

1063771
100x100 . 40"x40"
lux-rett ■ **A44**

✂ 8,5 mm - 5/16"

Fior Di Bosco



1062862
80x180 . 32"x72"
lux-rett ■ **A48**

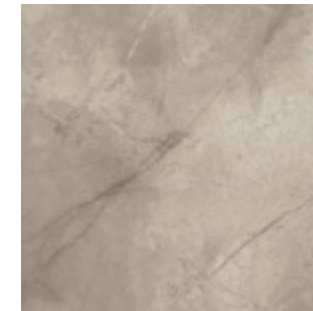

1063772
100x100 . 40"x40"
lux-rett ■ **A44**

Marquinia

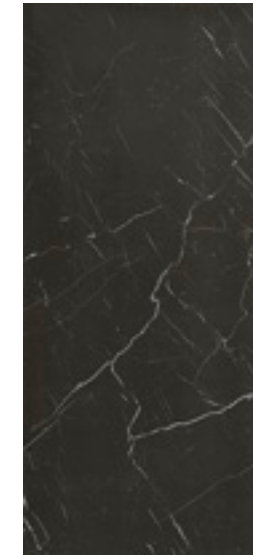

1062863
80x180 . 32"x72"
lux-rett ■ **A48**

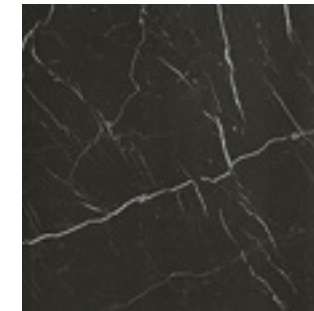

1063773
100x100 . 40"x40"
lux-rett ■ **A44**

✂ 8,5 mm - 5/16"



1063364
60x120 . 24"x48" lux-rett ■ **A42**

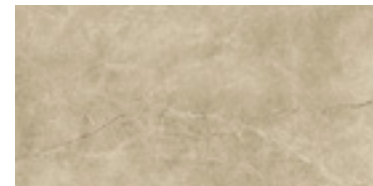

1063365
60x120 . 24"x48" lux-rett ■ **A42**

✂ 9,5 mm - 3/8"

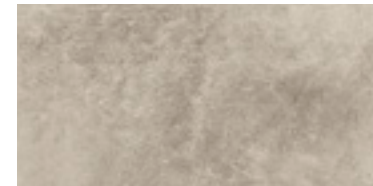

1063366
60x120 . 24"x48" lux-rett ■ **A42**

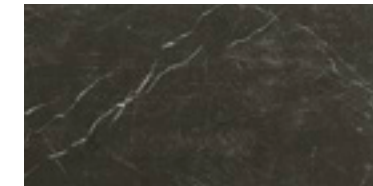

1063367
60x120 . 24"x48" lux-rett ■ **A42**

✂ 9,5 mm - 3/8"

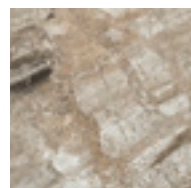

1063356
60x60 . 24"x24"
lux-rett ■ **A31**



1063765
30x60 . 12"x24"
lux-rett ■ **A27**



1063357
60x60 . 24"x24"
lux-rett ■ **A31**



1063766
30x60 . 12"x24"
lux-rett ■ **A27**



1063358
60x60 . 24"x24"
lux-rett ■ **A31**



1063767
30x60 . 12"x24"
lux-rett ■ **A27**

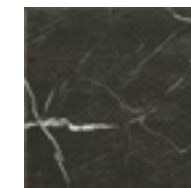

1063359
60x60 . 24"x24"
lux-rett ■ **A31**

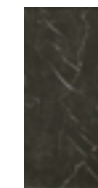

1063768
30x60 . 12"x24"
lux-rett ■ **A27**

MAGISTRA

marble

Colours



Paonazetto



1062864
80x180 . 32"x72"
lux-rett ■ **A48**

1063774
100x100 . 40"x40"
lux-rett ■ **A44**



1063368
60x120 . 24"x48" lux-rett ■ **A42**



1063360
60x60 . 24"x24"
lux-rett ■ **A31**



1063769
30x60 . 12"x24"
lux-rett ■ **A27**

✂ 8,5 mm - 5/16"

✂ 9,5 mm - 3/8"

Mosaics ✂ 9,5 mm - 3/8"

30x30 - 12"x12"
Foglio. Sheet. Feuille. Blatt. Лист

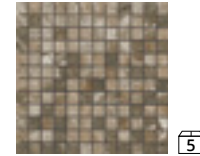

1063479
Mosaico Cappuccino
tessera 2,2x2,2 . 7/8"x7/8"
lux-rett ● **B19**

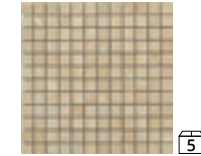

1063481
Mosaico Corinthian
tessera 2,2x2,2 . 7/8"x7/8"
lux-rett ● **B19**



1063482
Mosaico Fior di Bosco
tessera 2,2x2,2 . 7/8"x7/8"
lux-rett ● **B19**

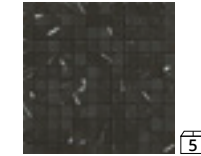

1063483
Mosaico Marquinia
tessera 2,2x2,2 . 7/8"x7/8"
lux-rett ● **B19**

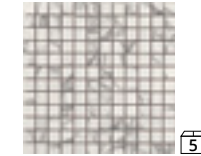

1063484
Mosaico Paonazetto
tessera 2,2x2,2 . 7/8"x7/8"
lux-rett ● **B19**

Trims ✂ 9,5 mm - 3/8"



Battiscopa
6,5x60 . 2 9/16"x24" lux-rett ► **C6**

- 1063611** Cappuccino
- 1063612** Corinthian
- 1063613** Fior di Bosco
- 1063614** Marquinia
- 1063615** Paonazetto

Trims ✂ 8,5 mm - 5/16"



Battiscopa
6,5x100 . 2 9/16"x40" lux-rett ► **C8**

- 1063616** Cappuccino
- 1063617** Corinthian
- 1063618** Fior di Bosco
- 1063619** Marquinia
- 1063620** Paonazetto

	BOX			PALLET		
	PZ	SQM	KGS	BOXES	SQM	KGS
80x180 . 32"x72" lux-rett	1	1,44	29,30	36	51,84	1.100
100x100 . 40"x40" lux-rett	1	1,00	19,00	42	42,00	814
	2	2,00	38,00	24	48,00	950
60x120 . 24"x48" lux-rett	2	1,44	32,00	36	51,84	1.190
60x60 . 24"x24" lux-rett	3	1,08	23,00	40	43,20	936
30x60 . 12"x24" lux-rett	6	1,08	23,00	40	43,20	936
Battiscopa 6,5x60 . 2 9/16"x24" lux-rett	12	7,20 ml	11,00			
Battiscopa 6,5x100 . 2 9/16"x40" lux-rett	6	6,00 ml	7,50			



FOSSIL

stile senza tempo

marble

GRES FINE PORCELLANATO SMALTATO
 GLAZED FINE PORCELAIN STONEWAREE
 GRÈS CÉRAME FIN ÉMAILLÉ
 GLASIERTES FEINSTEINZEUG
 ГЛАЗУРОВАННЫЙ КЕРАМОГРАНИТ



Colours

Bruno



Crema



Perla



Piombo

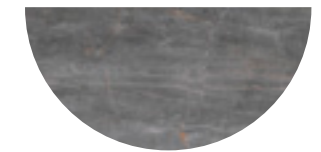

Finishes

MATT

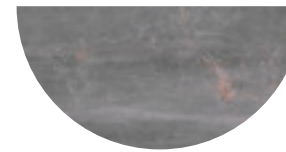

LUX

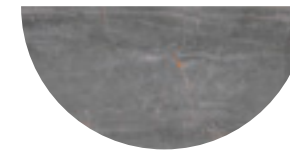

Sizes $\pm 8,5 \text{ mm} - \frac{5}{16}''$

100x100
40"x40"

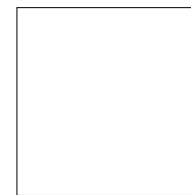

$\pm 9,5 \text{ mm} - \frac{3}{8}''$

60x120
24"x48"

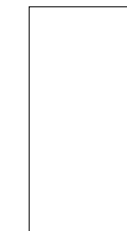

30x120
12"x48"



60x60
24"x24"



30x60
12"x24"





Bruno 60x120 . 24"x48" lux-rett
Wall04 Hypnotic (comp. 2pz) 120x120 . 48"x48" rett (Collezione Showall vedi pag. 204)



marble

Crema 60x120 . 24"x48" rett / Bruno 60x60 . 24"x24" lux-rett



Piombo 60x120 . 24"x48" rett



marble

Perla 100x100 . 40"x40" lux-rett

FOSSIL

marble

Colour

Bruno

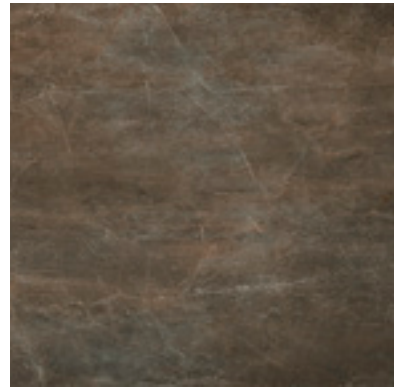

1066558 100x100 . 40"x40" lux-rett ■ A44

✂ 8,5 mm - 5/16"

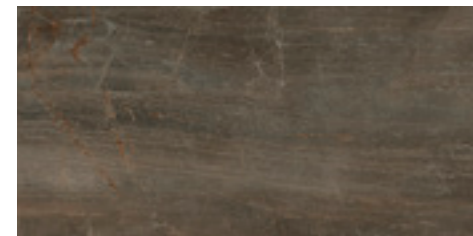

1066566 60x120 . 24"x48" lux-rett ■ A42

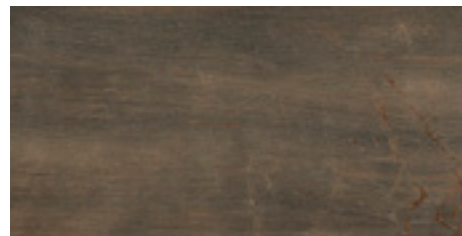

1066570 60x120 . 24"x48" rett ■ A29



1067947 Inserto Déco Bruno
60x60 . 24"x24" lux-rett ■ A39

✂ 9,5 mm - 3/8"

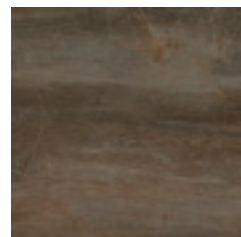

1066574 60x60 . 24"x24" lux-rett ■ A31

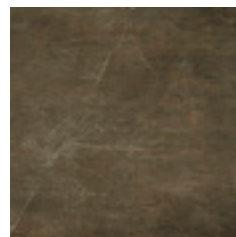

1066578 60x60 . 24"x24" rett ■ A14



1067943 Lines Bruno
30x120 . 12"x48" rett ■ A29



1066582 30x60 . 12"x24" lux-rett ■ A27



1066586 30x60 . 12"x24" rett ■ A10



1068531 Lines Bruno
30x60 . 12"x24" rett ■ A22

Crema

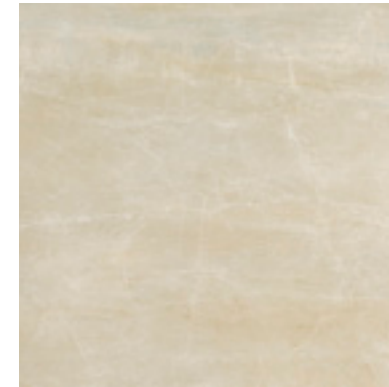

1066559 100x100 . 40"x40" lux-rett ■ A44

✂ 8,5 mm - 5/16"



1066567 60x120 . 24"x48" lux-rett ■ A42



1066571 60x120 . 24"x48" rett ■ A29



1067947 Inserto Déco Bruno
60x60 . 24"x24" lux-rett ■ A39

✂ 9,5 mm - 3/8"

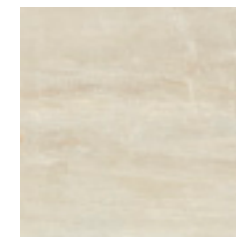

1066575 60x60 . 24"x24" lux-rett ■ A31

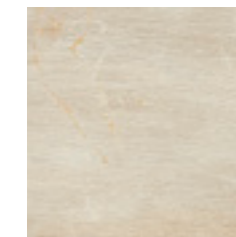

1066579 60x60 . 24"x24" rett ■ A14



1067944 Lines Crema
30x120 . 12"x48" rett ■ A29



1066583 30x60 . 12"x24" lux-rett ■ A27



1066587 30x60 . 12"x24" rett ■ A10



1068532 Lines Crema
30x60 . 12"x24" rett ■ A22

FOSSIL

marble

Colour



Perla

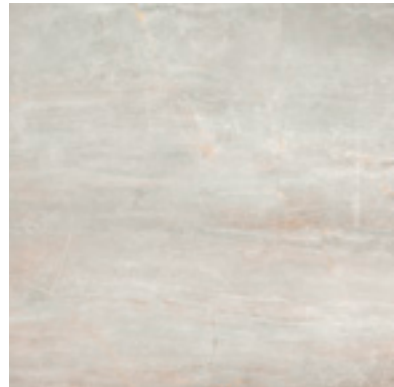

1066560 100x100 . 40"x40" lux-rett ■ **A44**

✂ 8,5 mm - 5/16"

Piombo

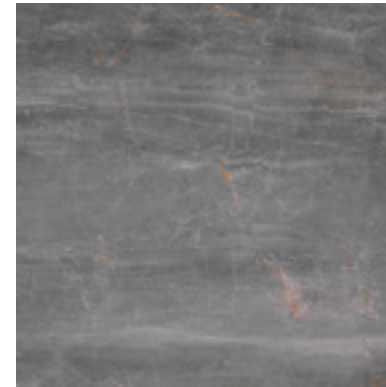

1066561 100x100 . 40"x40" lux-rett ■ **A44**

✂ 8,5 mm - 5/16"



1066568 60x120 . 24"x48" lux-rett ■ **A42**

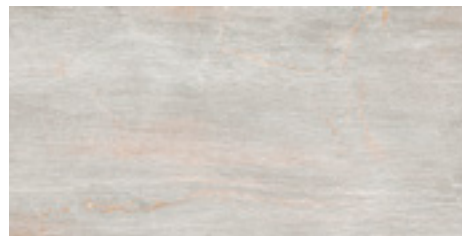

1066572 60x120 . 24"x48" rett ■ **A29**



1067948 Inserto Déco Piombo
60x60 . 24"x24" lux-rett ■ **A39**

✂ 9,5 mm - 3/8"

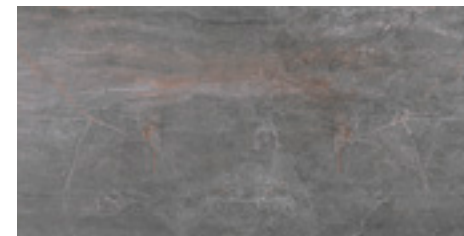

1066569 60x120 . 24"x48" lux-rett ■ **A42**



1066573 60x120 . 24"x48" rett ■ **A29**



1067948 Inserto Déco Piombo
60x60 . 24"x24" lux-rett ■ **A39**

✂ 9,5 mm - 3/8"

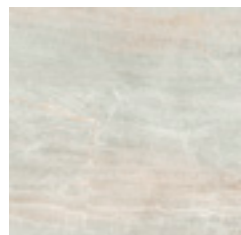

1066576 60x60 . 24"x24" lux-rett ■ **A31**

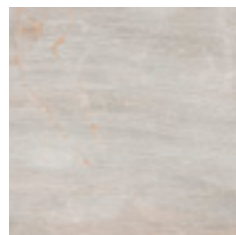

1066580 60x60 . 24"x24" rett ■ **A14**



1067945 Lines Perla
30x120 . 12"x48" rett ■ **A29**

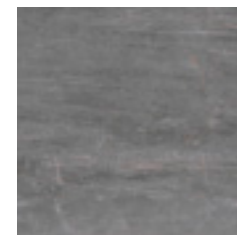

1066577 60x60 . 24"x24" lux-rett ■ **A31**

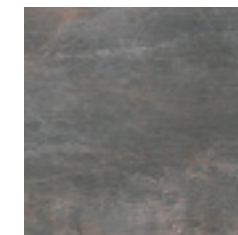

1066581 60x60 . 24"x24" rett ■ **A14**

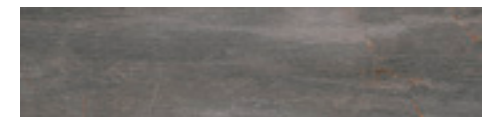

1067946 Lines Piombo
30x120 . 12"x48" rett ■ **A29**



1066584 30x60 . 12"x24" lux-rett ■ **A27**



1066588 30x60 . 12"x24" rett ■ **A10**



1068533 Lines Perla
30x60 . 12"x24" rett ■ **A22**



1066585 30x60 . 12"x24" lux-rett ■ **A27**

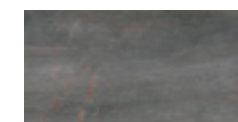

1066589 30x60 . 12"x24" rett ■ **A10**



1068534 Lines Piombo
30x60 . 12"x24" rett ■ **A22**

FOSSIL

Mosaics 9,5 mm - 3/8"

30x30 - 12"x12"
Foglio. Sheet. Feuille. Blatt. Лист

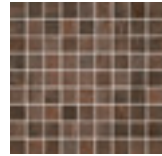

1066627 Mosaico Bruno
tessera 3x3 . 1¹³/₁₆"x1¹³/₁₆"
lux-rett ● **B17**

1066631 Mosaico Bruno
tessera 3x3 . 1¹³/₁₆"x1¹³/₁₆"
rett ● **B16**



1066628 Mosaico Crema
tessera 3x3 . 1¹³/₁₆"x1¹³/₁₆"
lux-rett ● **B17**

1066633 Mosaico Crema
tessera 3x3 . 1¹³/₁₆"x1¹³/₁₆"
rett ● **B16**



1066629 Mosaico Perla
tessera 3x3 . 1¹³/₁₆"x1¹³/₁₆"
lux-rett ● **B17**

1066634 Mosaico Perla
tessera 3x3 . 1¹³/₁₆"x1¹³/₁₆"
rett ● **B16**

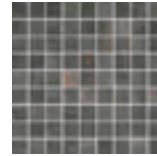

1066630 Mosaico Piombo
tessera 3x3 . 1¹³/₁₆"x1¹³/₁₆"
lux-rett ● **B17**

1066635 Mosaico Piombo
tessera 3x3 . 1¹³/₁₆"x1¹³/₁₆"
rett ● **B16**



1066636 Mosaico
Losanga Bruno 30x30 . 12"x12"
lux-rett ● **B24**

1066640 Mosaico
Losanga Bruno 30x30 . 12"x12"
rett ● **B22**



1066637 Mosaico
Losanga Crema 30x30 . 12"x12"
lux-rett ● **B24**

1066641 Mosaico
Losanga Crema 30x30 . 12"x12"
rett ● **B22**



1066638 Mosaico
Losanga Perla 30x30 . 12"x12"
lux-rett ● **B24**

1066642 Mosaico
Losanga Perla 30x30 . 12"x12"
rett ● **B22**



1066639 Mosaico
Losanga Piombo 30x30 . 12"x12"
lux-rett ● **B24**

1066643 Mosaico
Losanga Piombo 30x30 . 12"x12"
rett ● **B22**



1066644 Mosaico
Basket Bruno 30x30 - 12"x12"
lux-rett ● **B18**

1066648 Mosaico
Basket Bruno 30x30 - 12"x12"
rett ● **B17**



1066645 Mosaico
Basket Crema 30x30 - 12"x12"
lux-rett ● **B18**

1066649 Mosaico
Basket Crema 30x30 - 12"x12"
rett ● **B17**



1066646 Mosaico
Basket Perla 30x30 - 12"x12"
lux-rett ● **B18**

1066650 Mosaico
Basket Perla 30x30 - 12"x12"
rett ● **B17**



1066647 Mosaico
Basket Piombo 30x30 - 12"x12"
lux-rett ● **B18**

1066651 Mosaico
Basket Piombo 30x30 - 12"x12"
rett ● **B17**

Decors* 9,5 mm - 3/8"

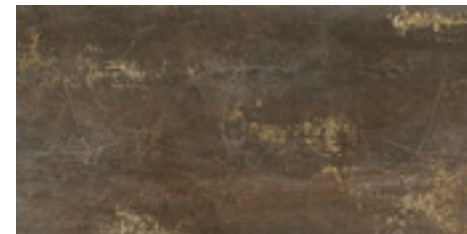

1069615 Inserto Gold Bruno
60x120 . 24"x48" lux-rett ● **B63C**



1069626 Lines Gold Bruno
30x120 . 12"x48" rett ● **B44**



1069620 Inserto Gold Perla
60x120 . 24"x48" lux-rett ● **B63C**



1069631 Lines Gold Perla
30x120 . 12"x48" rett ● **B44**

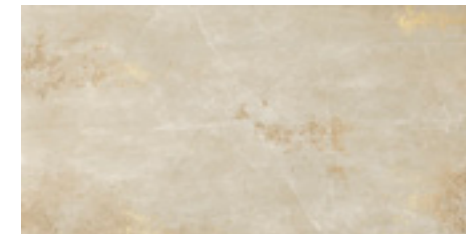

1069618 Inserto Gold Crema
60x120 . 24"x48" lux-rett ● **B63C**



1069629 Lines Gold Crema
30x120 . 12"x48" rett ● **B44**

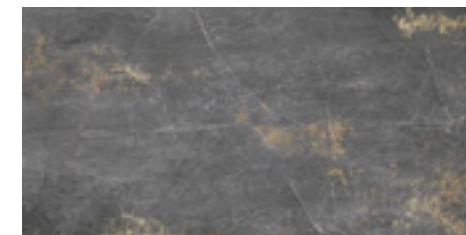

1069622 Inserto Gold Piombo
60x120 . 24"x48" lux-rett ● **B63C**

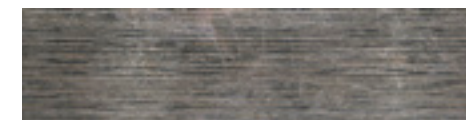

1069633 Lines Gold Piombo
30x120 . 12"x48" rett ● **B44**

* Decori da rivestimento ad uso residenziale interno. Wall decorations for interior residential.
Décor mural pour usage résidentiel intérieur. Wanddekore nur für Innenbereich geeignet. Декоры для отделки стен жилых помещений.

FOSSIL

Trims  9,5 mm - 3/8"



Battiscopa
6,5x60 . 2⁹/₁₆"x24" lux-rett ► **C6**
1066656 Bruno
1066657 Crema
1066658 Perla
1066659 Piombo



Battiscopa
6,5x60 . 2⁹/₁₆"x24" rett ► **C5**
1066660 Bruno
1066661 Crema
1066662 Perla
1066663 Piombo

 8,5 mm - 5/16"



Battiscopa
6,5x100 . 2⁹/₁₆"x40" lux-rett ► **C8**
1066652 Bruno
1066653 Crema
1066654 Perla
1066655 Piombo

	BOX			PALLET		
	PZ	SQM	KGS	BOXES	SQM	KGS
100x100 . 40"x40" lux-rett	1	1,00	19,00	42	42,00	814
	2	2,00	38,00	24	48,00	950
60x120 . 24"x48" lux-rett	2	1,44	32,00	36	51,84	1.190
60x120 . 24"x48" rett	2	1,44	31,00	36	51,84	1.144
60x60 . 24"x24" lux-rett / rett / Decò	3	1,08	22,80	40	43,20	928
30x60 . 12"x24" lux-rett	6	1,08	23,00	40	43,20	936
30x60 . 12"x24" rett	6	1,08	22,80	40	43,20	928
Lines 30x120 . 12"x48" rett	4	1,44	31,00	24	34,56	760
Lines 30x60 . 12"x24" rett	6	1,08	22,80	40	43,20	928
Battiscopa 6,5x60 . 2 ⁹ / ₁₆ "x24" lux-rett / rett	12	7,20 ml	11,00			
Battiscopa 6,5x100 . 2 ⁹ / ₁₆ "x40" rett	6	6,00 ml	8,00			



marble

Inserto Gold Perla 60x120 . 24"x48" lux-rett



DUOMO

eleganza eterna

marble

GRES FINE PORCELLANATO SMALTATO
GLAZED FINE PORCELAIN STONEWAREE
GRÈS CÉRAME FIN ÉMAILLÉ
GLASIERTES FEINSTEINZEUG
ГЛАЗУРОВАННЫЙ КЕРАМОГРАНИТ



Colours

Bianco



Crema



Grigio

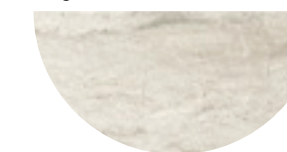

Noce



Finishes

MATT



✂ 10 mm - 3/8"

40x80
16"x32"



40x40
16"x16"



20x40
8"x16"



20x20
8"x8"



10x20
4"x8"



Grigio 10x20 . 4"x8" / 20x20 . 8"x8" / 40x40 . 16"x16"

DUOMO

Colours



Bianco

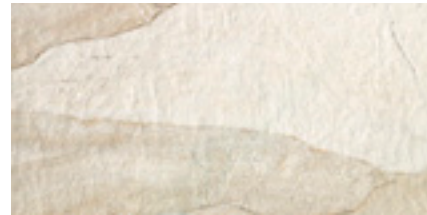

1049794 40x80 . 16"x32" ■ **A14**

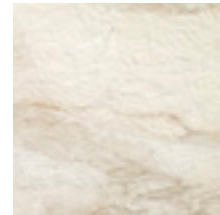

1049783 40x40 . 16"x16" ■ **A8**



1049798 20x40 . 8"x16" ■ **A8**

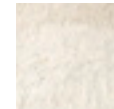

1049802 20x20 . 8"x8" ■ **A8**



1049806 10x20 . 4"x8" ■ **A11**

± 10 mm - 3/8"

Crema



1049795 40x80 . 16"x32" ■ **A14**

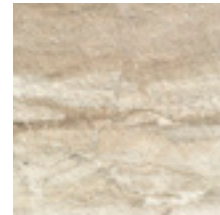

1049784 40x40 . 16"x16" ■ **A8**



1049799 20x40 . 8"x16" ■ **A8**

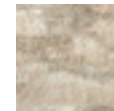

1049803 20x20 . 8"x8" ■ **A8**



1049807 10x20 . 4"x8" ■ **A11**

Grigio

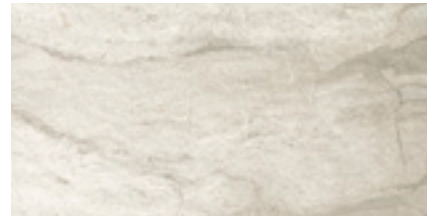

1049796 40x80 . 16"x32" ■ **A14**

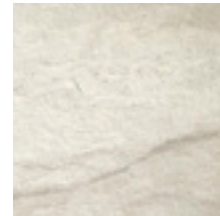

1049785 40x40 . 16"x16" ■ **A8**

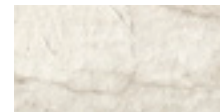

1049800 20x40 . 8"x16" ■ **A8**



1049804 20x20 . 8"x8" ■ **A8**



1049808 10x20 . 4"x8" ■ **A11**

Noce



1049797 40x80 . 16"x32" ■ **A14**

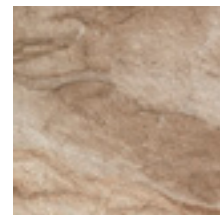

1049786 40x40 . 16"x16" ■ **A8**



1049801 20x40 . 8"x16" ■ **A8**



1049805 20x20 . 8"x8" ■ **A8**



1049809 10x20 . 4"x8" ■ **A11**

Mosaics ± 10 mm - 3/8"

30x30 - 12"x12"
Foglio. Sheet. Feuille. Blatt. Лист



1049829 Mosaico Duomo Bianco tessera 5x5 . 2"x2" ● **B13**



1049830 Mosaico Duomo Crema tessera 5x5 . 2"x2" ● **B13**



1049831 Mosaico Duomo Grigio tessera 5x5 . 2"x2" ● **B13**

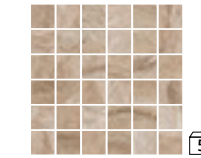

1049832 Mosaico Duomo Noce tessera 5x5 . 2"x2" ● **B13**

Trims ± 10 mm - 3/8"



Battiscopa
6,5x40 . 2 9/16"x16" ► **C3**

- 1050081** Bianco
- 1050082** Crema
- 1050083** Grigio
- 1050084** Noce

	BOX			PALLET		
	PZ	SQM	KGS	BOXES	SQM	KGS
40x80 . 16"x32"	3	0,96	19,50	28	26,88	565
40x40 . 16"x16"	8	1,28	25,60	48	61,44	1.245
20x40 . 8"x16"	13	1,04	20,80	54	56,16	1.130
20x20 . 8"x8"	26	1,04	20,80	54	56,16	1.130
10x20 . 4"x8"	36	0,72	14,40	72	51,84	1.055
Battiscopa 6,5x40 . 2 9/16"x16"	20	8,00 ml	10,00			

5

cotto



RIABITA IL COTTO

classico contemporaneo

cotto

GRES PORCELLANATO SMALTATO COLORATO IN MASSA
GLAZED PORCELAIN STONEWARE WITH COLOURED BODY
GRÈS CÉRAMÉ ÉMAILLÉ COLORÉ DANS LA MASSE
GLASIERTES FEINSTEINZEUG IN DER MASSE GEFÄRBT
ГЛАЗУРОВАННЫЙ КЕРАМОГРАНИТ, ОКРАШЕННЫЙ ПО ВСЕЙ ТООЛЩИНЕ



Colours

Classic



Minimal



Natural



Shabby Chic



Finishes

MATT



✂ 10 mm - 3/8"

40x80
16"x32"



40x40
16"x16"



20x40
8"x16"



20x20
8"x8"



RIABITA IL COTTO

Colours



Classic



1046380 40x80 . 16"x32" ■ A14



1046385 40x40 . 16"x16" ■ A8



1046391 20x40 . 8"x16" ■ A8



1046685 20x20 . 8"x8" ■ A8

± 10 mm - 3/8"

Minimal

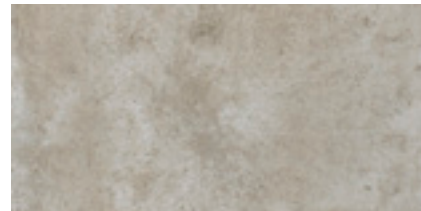

1046483 40x80 . 16"x32" ■ A14

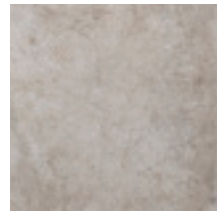

1046481 40x40 . 16"x16" ■ A8

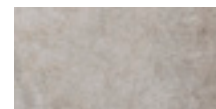

1046480 20x40 . 8"x16" ■ A8

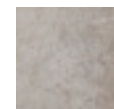

1046688 20x20 . 8"x8" ■ A8

Natural

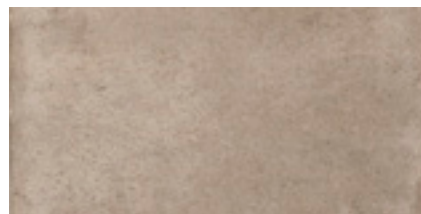

1046383 40x80 . 16"x32" ■ A14

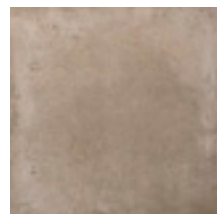

1046389 40x40 . 16"x16" ■ A8



1046394 20x40 . 8"x16" ■ A8



1046689 20x20 . 8"x8" ■ A8

Shabby Chic

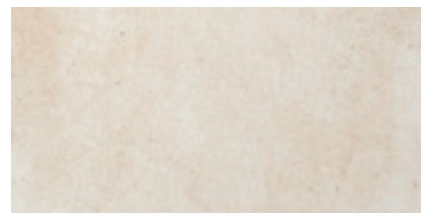

1046384 40x80 . 16"x32" ■ A14

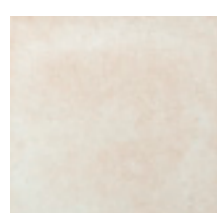

1046390 40x40 . 16"x16" ■ A8



1046395 20x40 . 8"x16" ■ A8

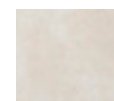

1046690 20x20 . 8"x8" ■ A8

Colours



Fabric Mix



Fabric (9 soggetti mix)*
40x40 . 16"x16"

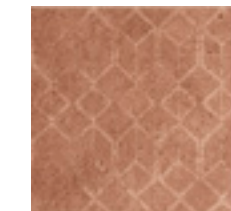

1046396 Fabric Mix Classic 40x40 . 16"x16" ■ A17



1046482 Fabric Mix Minimal 40x40 . 16"x16" ■ A17

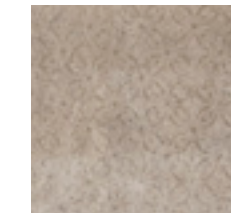

1046399 Fabric Mix Natural 40x40 . 16"x16" ■ A17

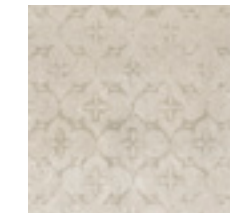

1046400 Fabric Mix Shabby Chic 40x40 . 16"x16" ■ A17

± 10 mm - 3/8"

Mosaics ± 10 mm - 3/8"

30x30 - 12"x12"
Foglio. Sheet. Feuille. Blatt. Лист

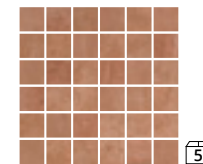

1046889 Mosaico Riabita Classic tessera 5x5 . 2"x2" ● B13



1046892 Mosaico Riabita Minimal tessera 5x5 . 2"x2" ● B13

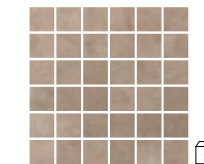

1046893 Mosaico Riabita Natural tessera 5x5 . 2"x2" ● B13



1046894 Mosaico Riabita Shabby Chic tessera 5x5 . 2"x2" ● B13

* Soggetti miscelati casualmente nelle scatole. Designs available with each box containing a random mix. Motifs mélangés au hasard dans les boîtes. Muster in den Schachteln werden nach den Zufallsprinzip gemischt. Вариантов, в коробке упакована произвольная смесь из них.

RIABITA IL COTTO

Decors* $\pm 10 \text{ mm} - 3/8''$

Pattern

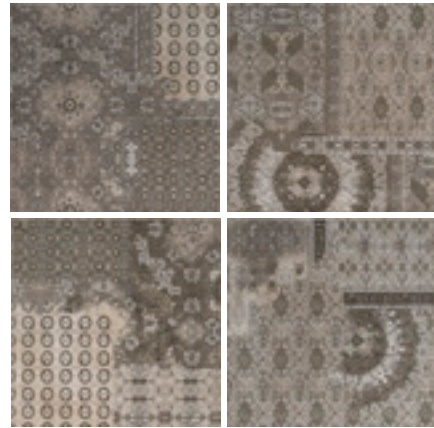

1047041 Inserto Pattern Grey S/4
40x40 . 16"x16" ■ **A53**

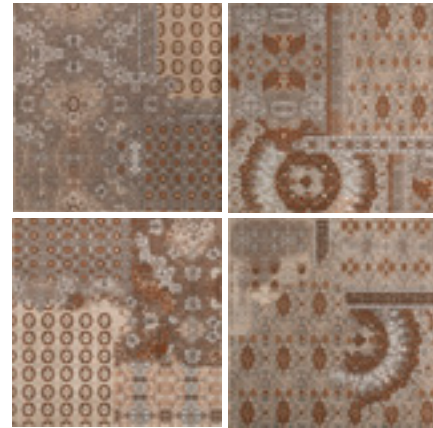

1047040 Inserto Pattern Beige S/4
40x40 . 16"x16" ■ **A53**

Vanity



1047754 Inserto Vanity Warm S/1 ■ **A60**
40x40 . 16"x16"

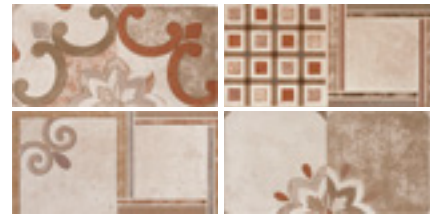

1046336 Inserto Vanity Warm s/4
20x40 . 8"x16" ● **B19**

New Glam

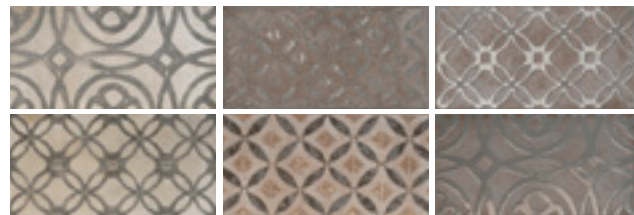

1046816 Inserto New Glam Cold s/6
20x40 . 8"x16" ● **B17**

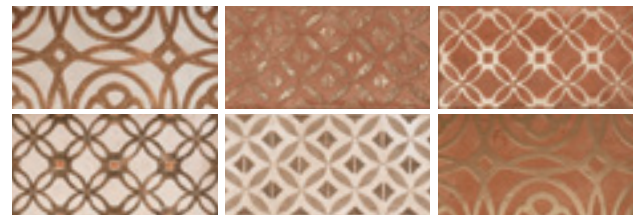

1046817 Inserto New Glam Warm s/6
20x40 . 8"x16" ● **B17**

Trims $\pm 10 \text{ mm} - 3/8''$



Battiscopa
6,5x40 . 2 9/16"x16" ► **C3**
1050095 Classic
1050098 Minimal
1050099 Natural
1050100 Shabby Chic



Gradone con frontale Monolitico
30x33x4,5 . 12"x13"x1 7/8" ● **B33**
1047465 Classic
1047495 Minimal
1047424 Natural
1047496 Shabby Chic



Angolare
33x33 . 13"x13" ● **B40**
1047466 Classic
1047497 Minimal
1047498 Natural
1047499 Shabby Chic



Battiscopa Scala (comp 2 pz)
6,5x40 . 2 9/16"x16" ● **B16**
1050470 Classic Dx
1050471 Classic Sx
1053535 Minimal Dx
1053536 Minimal Sx
1050551 Natural Dx
1050552 Natural Sx
1053422 Shabby Chic Dx
1050966 Shabby Chic Sx

	BOX			PALLET		
	PZ	SQM	KGS	BOXES	SQM	KGS
40x80 . 16"x32"	3	0,96	21,60	28	26,88	621
40x40 . 16"x16" / Fabric	8	1,28	26,50	48	61,44	1.076
20x40 . 8"x16"	12	0,96	20,00	54	51,84	1.096
20x20 . 8"x8"	24	0,96	19,50	54	51,84	1.070
Battiscopa 6,5x40 . 2 9/16"x16"	20	8,00 ml	11,50			
Gradone con frontale Monolitico 30x33x4,5 . 12"x13"x1 7/8"	6		16,80			
Angolare 33x33 . 13"x13"	2		6,80			
Battiscopa scala comp. 2 pz 6,5x40 . 2 9/16"x16"	comp 7		10,00			

* Decori da rivestimento ad uso residenziale interno. Wall decorations for interior residential.
Décor mural pour usage résidentiel intérieur. Wanddekore nur für Innenbereich geeignet. Декоры для отделки стен жилых помещений.

6

204 SHOWALL

decors



SHOWALL

prêt-à-porter
ceramic wide decoration

decors

GRES FINE PORCELLANATO SMALTATO
GLAZED FINE PORCELAIN STONEWAREE
GRÈS CÉRAME FIN ÉMAILLÉ
GLASIERTES FEINSTEINZEUG
ГЛАЗУРОВАННЫЙ КЕРАМОГРАНИТ



Decors

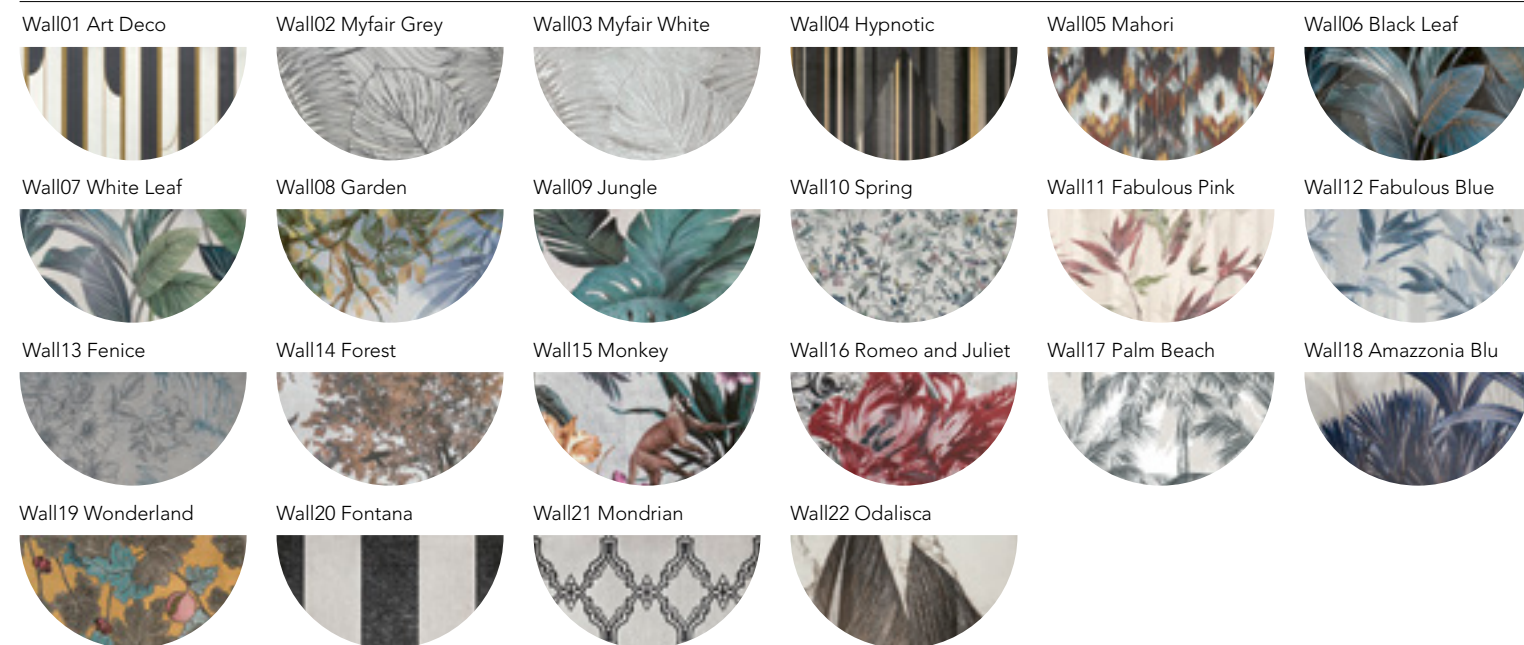

± 9,5 mm - 3/8"

60x120
24"x48"

120x120 Comp 2 pz
48"x48"

60x240 Comp 2 pz
24"x96"

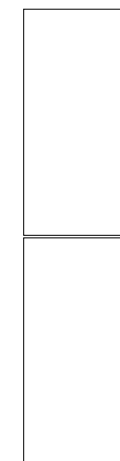
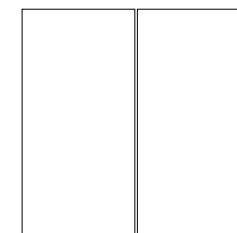

Wall18 Amazonia Blu (comp 2 pz) 120x120 . 48"x48" rett

SHOWWALL

Decors*

± 9,5 mm - 3/8"

± 9,5 mm - 3/8"

Wall04 Hypnotic

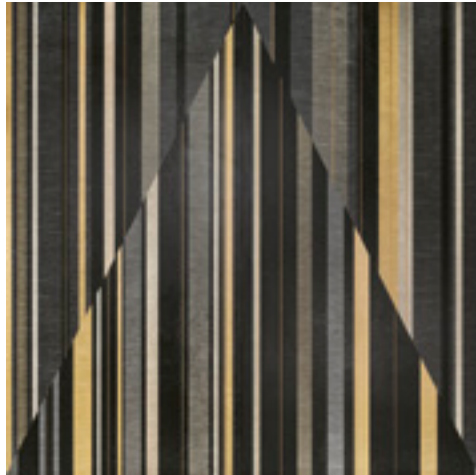

1069817 Wall04 Hypnotic comp 2 PZ
120x120 . 48"x48" rett ● **B71**

Wall06 Black Leaf



1069819 Wall06 Black Leaf comp 2 PZ
120x120 . 48"x48" rett ● **B72**

Wall07 White Leaf



1069821 Wall07 White Leaf comp 2 PZ
120x120 . 48"x48" rett ● **B68**

Wall14 Forest



1070296 Wall14 Forest comp 2 PZ
120x120 . 48"x48" rett ● **B68**

Wall15 Monkey

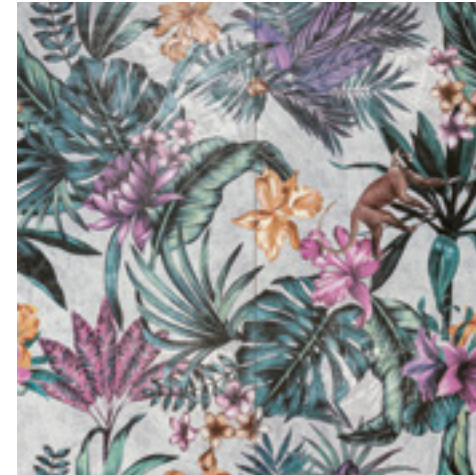

1070301 Wall15 Monkey comp 2 PZ
120x120 . 48"x48" rett ● **B68**

Wall16 Romeo and Juliet



1070329 Wall16 Romeo and Juliet comp 2 PZ
120x120 . 48"x48" rett ● **B68C**

Wall08 Garden



1069823 Wall08 Garden comp 2 PZ
120x120 . 48"x48" rett ● **B67**

Wall09 Jungle



1069825 Wall09 Jungle comp 2 PZ
120x120 . 48"x48" rett ● **B68**

Wall13 Fenice



1070292 Wall13 Fenice comp 2 PZ
120x120 . 48"x48" rett ● **B68C**

Wall17 Palm Beach



1074003 Wall17 Palm Beach comp 2 PZ
120x120 . 48"x48" rett ● **B68C**

Wall18 Amazonia Blu



1074004 Wall18 Amazonia Blu comp 2 PZ
120x120 . 48"x48" rett ● **B72**

* Decori da rivestimento ad uso residenziale interno. Wall decorations for interior residential.
Décor mural pour usage résidentiel intérieur. Wanddekore nur für Innenbereich geeignet. Декоры для отделки стен жилых помещений.

	BOX		
	PZ	SQM	KGS
120x120 . 48"x48" rett	comp 1	1,44	31,00
60x120 . 24"x48" rett	2	1,44	31,00
60x240 . 24"x96" rett	comp 1	1,44	31,00

SHOWALL

Decors*

± 9,5 mm - 3/8"

± 9,5 mm - 3/8"

Wall01 Art Deco



1069815 Wall01 Art Deco
60x120 . 24"x48" rett ● **B62C**

Wall02 Myfair Grey



1070215 Wall02 Myfair Grey
60x120 . 24"x48" rett ● **B62C**

Wall03 Myfair White

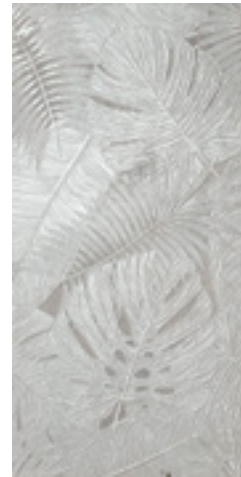

1070217 Wall03 Myfair White
60x120 . 24"x48" rett ● **B62C**

Wall12 Fabulous Blue



1069831 Wall12 Fabulous Blue
60x120 . 24"x48" rett ● **B62C**

Wall19 Wonderland



1074005 Wall19 Wonderland
60x120 . 24"x48" rett ● **B63B**

Wall22 Odalisca



1074008 Wall22 Odalisca comp 2 PZ
60x240 . 24"x96" rett ● **B72**

Wall05 Mahori



1070289 Wall05 Mahori
60x120 . 24"x48" rett ● **B63D**

Wall10 Spring

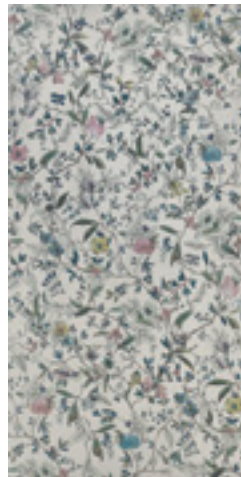

1069827 Wall10 Spring
60x120 . 24"x48" rett ● **B62C**

Wall11 Fabulous Pink



1069829 Wall11 Fabulous Pink
60x120 . 24"x48" rett ● **B62C**

Wall20 Fontana



1074006 Wall20 Fontana
60x120 . 24"x48" rett ● **B63**

Wall21 Mondrian



1074007 Wall21 Mondrian
60x120 . 24"x48" rett ● **B63**

* Decori da rivestimento ad uso residenziale interno. Wall decorations for interior residential.
Décor mural pour usage résidentiel intérieur. Wanddekore nur für Innenbereich geeignet. Декоры для отделки стен жилых помещений.

	BOX		
	PZ	SQM	KGS
120x120 . 48"x48" rett	comp 1	1,44	31,00
60x120 . 24"x48" rett	2	1,44	31,00
60x240 . 24"x96" rett	comp 1	1,44	31,00



diciannove

- 212 MATERICA 19 MM
- 214 STUDIO 50 19 MM
- 218 EVOCA 19 MM
- 220 PROMENADE 19 MM
- 222 I ROVERI 19 MM
- 224 RIABITA IL COTTO 19 MM



MATERICA

19 MM

Colours 19 mm - 13/16"



Ecrú R11



1075384 80x80 . 32"x32"
rett R11 ■ **A46**

Perla R11



1075386 80x80 . 32"x32"
rett R11 ■ **A46**

Platino R11

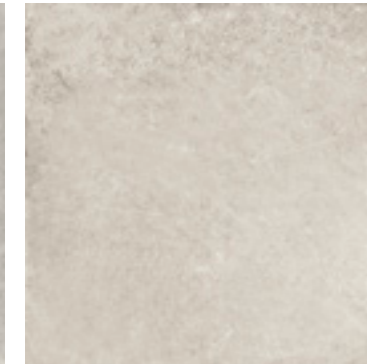

1075387 80x80 . 32"x32"
rett R11 ■ **A46**

Tortora R11



1075388 80x80 . 32"x32"
rett R11 ■ **A46**

Trims 19 mm - 13/16"



Step Molato R11
40x80 . 16"x32" rett ● **B42**
1078445 Ecrú
1078446 Perla
1078447 Platino
1078448 Tortora



Step Torato R11
40x80 . 16"x32" rett ● **B43**
1078449 Ecrú
1078450 Perla
1078451 Platino
1078452 Tortora



Elemento ad "L" Assemblato R11
15x80x5 . 6"x32"x2" rett ● **B49**
1078453 Ecrú
1078454 Perla
1078455 Platino
1078456 Tortora



Gradone Costa Retta R11
30x80x5 . 12"x32"x2" rett ● **B58**
1078457 Ecrú
1078458 Perla
1078459 Platino
1078460 Tortora

Platino 80x80 . 32"x32" R11 rett 19 mm / Pezzi speciali 19 MM rett
Perla Mosaico 5x5 . 2"x2" rett
Elementi: Piatto doccia Perla

	BOX			PALLET		
	PZ	SQM	KGS	BOXES	SQM	KGS
80x80 . 32"x32" rett	1	0,64	29,00	44	28,16	1.292



STUDIO 50

19 MM

Colours  19 mm - 13/16"



Studio Peltro R11



1068438 100x100 . 40"x40" rett ■ A46E

Studio Perla R11



1068439 100x100 . 40"x40" rett ■ A46E

Studio Verderame R11



1068442 100x100 . 40"x40" rett ■ A46E



1068443 60x60 . 24"x24" rett ■ A36

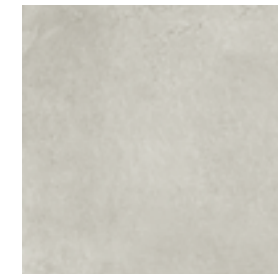

1068444 60x60 . 24"x24" rett ■ A36

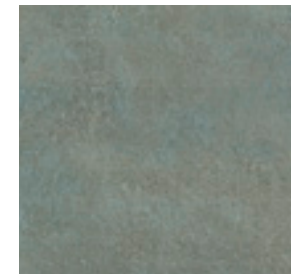

1068447 60x60 . 24"x24" rett ■ A36

Studio Verde Rame 100x100 . 40"x40" R11 19 MM rett

	BOX			PALLET		
	PZ	SQM	KGS	BOXES	SQM	KGS
100x100 . 40"x40" rett	1	1,00	42,50	21	21,00	926
60x60 . 24"x24" rett	2	0,72	30,60	32	23,04	996

STUDIO 50

19 MM

Colours  19 mm - 13/16"



Studio Sabbia R11

Studio Terracotta R11



1068440 100x100 . 40"x40" rett ■ **A46E**

1068441 100x100 . 40"x40" rett ■ **A46E**



1068445 60x60 . 24"x24" rett ■ **A36**

1068446 60x60 . 24"x24" rett ■ **A36**

Trims  19 mm - 13/16"



Step Molato R11
33x100 . 13"x40" rett ● **B56**
1070972 Studio Peltro
1070973 Studio Perla
1070974 Studio Sabbia
1070975 Studio Terracotta
1070976 Studio Verderame

Step Torato R11
33x100 . 13"x40" rett ● **B57**
1070977 Studio Peltro
1070978 Studio Perla
1070979 Studio Sabbia
1070980 Studio Terracotta
1070981 Studio Verderame

Elemento ad "L" Assemblato R11
15x100x5 . 6"x40"x2" rett ● **B54**
1070901 Studio Peltro
1070902 Studio Perla
1070903 Studio Sabbia
1070904 Studio Terracotta
1070905 Studio Verderame

Gradone Costa Retta R11
30x100x5 . 12"x40"x2" rett ● **B60**
Studio Peltro
Studio Perla
Studio Sabbia
Studio Terracotta
Studio Verderame



Step Molato R11
30x60 . 12"x24" rett ● **B36**
1070870 Studio Peltro
1070871 Studio Perla
1070872 Studio Sabbia
1070873 Studio Terracotta
1070874 Studio Verderame

Step Torato R11
30x60 . 12"x24" rett ● **B37**
1070875 Studio Peltro
1070876 Studio Perla
1070877 Studio Sabbia
1070878 Studio Terracotta
1070879 Studio Verderame

Elemento ad "L" Assemblato R11
15x60x5 . 6"x24"x2" rett ● **B43**
1070880 Studio Peltro
1070881 Studio Perla
1070882 Studio Sabbia
1070883 Studio Terracotta
1070884 Studio Verderame

Gradone Costa Retta R11
30x60x5 . 12"x24"x2" rett ● **B52**
Studio Peltro
Studio Perla
Studio Sabbia
Studio Terracotta
Studio Verderame

	BOX			PALLET		
	PZ	SQM	KGS	BOXES	SQM	KGS
100x100 . 40"x40" rett	1	1,00	42,50	21	21,00	926
60x60 . 24"x24" rett	2	0,72	30,60	32	23,04	996



EVOCA

19 MM

Colours  19 mm - 13/16"

R11  V2  

Ambra R11

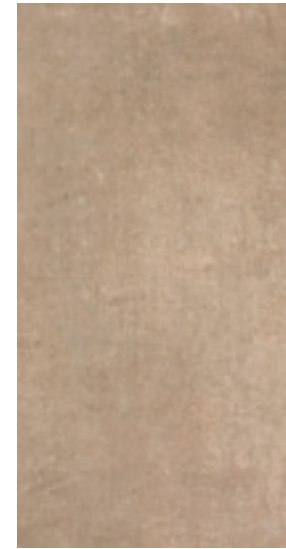

1065234 60x120 . 24"x48"
rett R11 ■ **A46**

Avorio R11

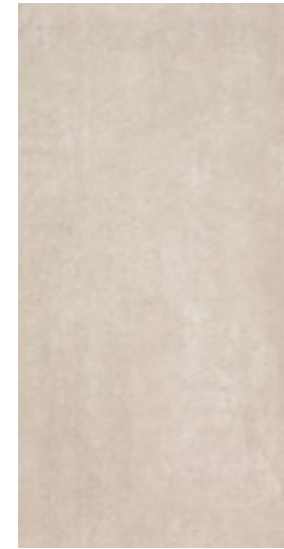

1065235 60x120 . 24"x48"
rett R11 ■ **A46**

Cenere R11



1065236 60x120 . 24"x48"
rett R11 ■ **A46**

Grafite R11



1065237 60x120 . 24"x48"
rett R11 ■ **A46**

Terra R11



1065238 60x120 . 24"x48"
rett R11 ■ **A46**

Trims  19 mm - 13/16"



Step Molato R11
30x120 . 12"x48" rett ● **B53**
1065272 Ambra
1065273 Avorio
1065274 Cenere
1065275 Grafite
1065276 Terra



Step Torato R11
30x120 . 12"x48" rett ● **B55**
1065277 Ambra
1065278 Avorio
1065279 Cenere
1065280 Grafite
1065281 Terra



Elemento ad "L" Assemblato R11
15x60x5 . 6"x24"x2" rett ● **B43**
1065282 Ambra
1065283 Avorio
1065284 Cenere
1065285 Grafite
1065286 Terra



Gradone Costa Retta R11
30x60x5 . 12"x24"x2" rett ● **B52**
Ambra
Avorio
Cenere
Grafite
Terra

Ambra 60x120 . 24"x48" R11 19 MM rett

	BOX			PALLET		
	PZ	SQM	KGS	BOXES	SQM	KGS
60x120 . 24"x48" rett	1	0,72	30,60	36	25,92	1.118



PROMENADE

19 MM

Colours 19 mm - 13/16"



Argento R11

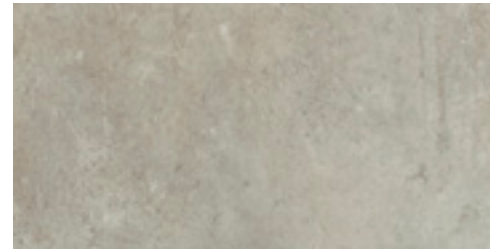

1068041 60x120 . 24"x48" rett ■ A46

Corda R11

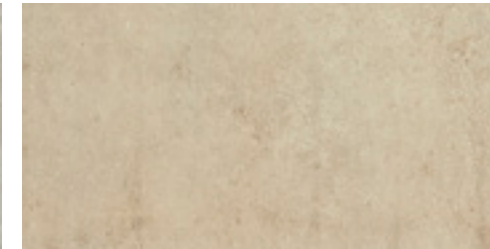

1068042 60x120 . 24"x48" rett ■ A46

Sabbia R11

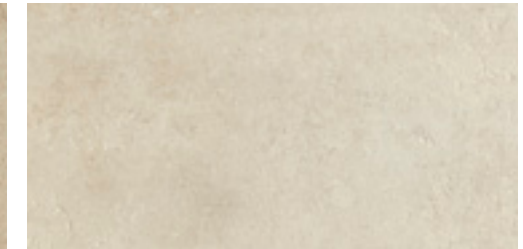

1068043 60x120 . 24"x48" rett ■ A46

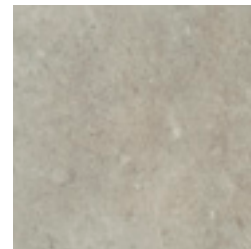

1070525 60x60 . 24"x24" rett ■ A36

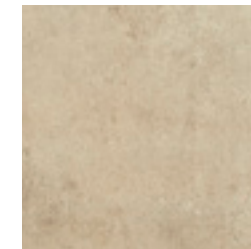

1070526 60x60 . 24"x24" rett ■ A36

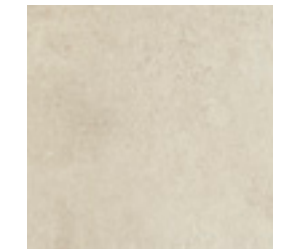

1070527 60x60 . 24"x24" rett ■ A36

Trims 19 mm - 13/16"



Step Molato R11
30x120 . 12"x48" rett ● B53
1070851 Argento
1070852 Corda
1070853 Sabbia



Step Torato R11
30x120 . 12"x48" rett ● B55
1070854 Argento
1070855 Corda
1070856 Sabbia



Elemento ad "L" Assemblato R11
15x60x5 . 6"x24"x2" rett ● B43
1070858 Argento
1070859 Corda
1070860 Sabbia



Gradone Costa Retta R11
30x60x5 . 12"x24"x2" rett ● B52
Argento
Corda
Sabbia

Sabbia 60x120 . 24"x48" R11 19 MM rett

	BOX			PALLET		
	PZ	SQM	KGS	BOXES	SQM	KGS
60x120 . 24"x48" rett	1	0,72	30,60	36	25,92	1.118
60x60 . 24"x24" rett	2	0,72	30,60	32	23,04	996



I ROVERI

Colours 19 mm - 13/16"



Rovere Antico **R11**



1077601 30x120 . 12"x48" rett R11 ■ **A46**

Rovere Intenso **R11**



1077602 30x120 . 12"x48" rett R11 ■ **A46**

Rovere Naturale **R11**

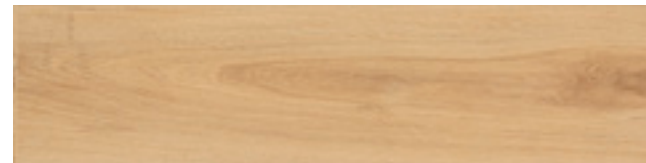

1077603 30x120 . 12"x48" rett R11 ■ **A46**

Trims 19 mm - 13/16"



Step Molato R11
30x120 . 12"x48" rett ● **B53**
1078484 Rovere Antico
1078486 Rovere Intenso
1078487 Rovere Naturale



Step Torato R11
30x120 . 12"x48" rett ● **B55**
1078489 Rovere Antico
1078490 Rovere Intenso
1078491 Rovere Naturale



Elemento ad "L" Assemblato R11
15x60x5 . 6"x24"x2" rett ● **B43**
1078492 Rovere Antico
1078493 Rovere Intenso
1078494 Rovere Naturale



Gradone Costa Retta R11
30x60x5 . 12"x24"x2" rett ● **B52**
Rovere Antico
Rovere Intenso
Rovere Naturale

Rovere Antico 30x120 . 12"x48" R11 19 MM rett

	BOX			PALLET		
	PZ	SQM	KGS	BOXES	SQM	KGS
30x120 . 12"x48" rett	2	0,72	30,60	24	17,28	760



RIABITA IL COTTO

19 MM

Colours  19 mm - 13/16"



Classic R11



1047018 60x60 . 24"x24" rett  A37

Trims  19 mm - 13/16"



Step Molato R11
30x60 . 12"x24" rett  B36
1054549 Classic



Step Torato R11
30x60 . 12"x24" rett  B37
1053564 Classic



Elemento ad "L" Assemblato R11
15x60x5 . 6"x24"x2" rett  B43
1048295 Classic



Gradone Costa Retta R11
30x60x5 . 12"x24"x2" rett  B52
Classic

Classic 60x60 . 24"x24" R11 19 MM rett

	BOX			PALLET		
	PZ	SQM	KGS	BOXES	SQM	KGS
60x60 . 24"x24" rett	2	0,72	30,60	32	23,04	996

19mm dove?

WHERE? OÙ? WO? ГДЕ?



19 MILLIMETRI PER LA CASA

19 millimeters for the home | 19 mm pour la maison
19 mm für die wohnung | 19 миллиметров для дома

IN GIARDINO.

In the garden. Dans le jardin.
Im Garten. В саду.

NEL PATIO E NELLE TERRAZZE.

In the patio and terraces. Sous le porche et sur les terrasses.
Im Innenhof und auf Terrassen. На patio или на террасах.

NELLE SCALE E NEI VIALETTI.

In the stairways and walkways. Sur les escaliers et dans les ruelle.
Auf Treppen und Wegen. На лестницах и на аллеях.

IN PISCINA.

In the swimming pool. En piscine.
Im Schwimmbad. В бассейне.



19 MILLIMETRI NEGLI SPAZI PUBBLICI

19 millimeters for public spaces | 19 mm dans les espaces publics
19 mm in öffentlichen bereichen | 19 миллиметров в общественных пространствах

NEI RISTORANTI E HOTEL.

In the hospitality. Dans les restaurants et dans les hôtels.
In Gästebereichen. В гостиничных заведениях.

NEGLI STABILIMENTI BALNEARI.

In the bathing establishments. Dans les établissements balnéaires.
In Badeanstalten. На пляжах.

NELLE AREE COMMERCIALI.

In the commercial areas. Dans les zones commerciales.
In Gewerbebereichen. В коммерческих зонах.

NEI CAMMINAMENTI E NELL'ARREDO URBANO.

In the walkways and urban environment. Dans la passerelle et dans la décoration urbaine.
Auf Gehwegen und in Stadtbereichen. На дорожках и в городском благоустройстве.

19mm perchè?

WHY? POURQUOI? WARUM? ПОЧЕМУ?



PERCHÈ RESISTE ALLA FLESSIONE E ALLA FORZA DI ROTTURA

Modulus of rupture and breaking strength
Résistant à la flexion et à la force de rupture
Biegefestigkeit und Bruchlast
прочная на изгиб и устойчивая к разрушающим усилиям



PERCHÈ RESISTE AI CARICHI DI ROTTURA CON SUPPORTO

Charge of rupture with support
Résistant aux charges de rupture avec support
Biegefestigkeit und Bruchlast
устойчивая к разрушающим усилиям с основой

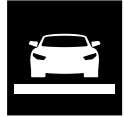

PERCHÈ È CARRABILE

Drive-over
Carrassable
Befahrbar
допускает движение транспортных средств



PERCHÈ È FACILE DA POSARE ED È RETTIFICATO

Easy to fit and it is rectified
Parce qu'il est facile à poser
Leicht verlegen und rektifiziert
легко укладывается, обрезная



PERCHÈ È COORDINABILE INDOOR/OUTDOOR

Because it can match indoor and outdoor
Parce qu'il coordonne l'intérieur/extérieur
Weil er für Innen- und Außenbereiche koordinierbar ist
потому, что интерьер и экстерьер сочетаются друг с другом



PERCHÈ È FACILE DA PULIRE

Easy to clean
Facile à nettoyer
Pflegeleicht
легко чистится



PERCHÈ È REMOVIBILE E ISPEZIONABILE

Because it can be removed and inspected
Facile à enlever et à contrôler
Weil er entfernbar und inspektionierbar ist
потому, что он съемный и осматриваемый



PERCHÈ È IGNIFUGO

Resistant to fire
Ignifuge
Feuerbeständig
огнестойкая и негорючая



PERCHÈ RESISTE ALLA SCIVOLOSITÀ

Skid resistance
Antidérapant
Rutschfestigkeit
Сопротивление скольжению



PERCHÈ RESISTE ALLA MUFFA, AL MUSCHIO E AL SALE

Resistant to mold, moss and salt
Résistant à la moisissure, à la mousse et au sel
Resistent gegen Schimmel, Moos und Salz
Устойчива к плесени, мху и соли

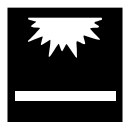

PERCHÈ RESISTE AI COLORI E ALLA LUCE

Color resistance to light
Aucune altération des couleurs à la lumière
Lichtbeständigkeit
Устойчива к краске и свету



PERCHÈ RESISTE AL GELO

Frost resistance
Résistant au gel
Frostbeständigkeit
Морозостойкая



PERCHÈ RESISTE ALLO SHOCK TERMICO

Thermal shock resistance
Résistant au choc thermique
Temperaturwechselbeständigkeit
Устойчива к тепловым перепадам

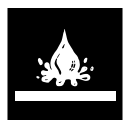

PERCHÈ NON ASSORBE ACQUA

No water absorption
Aucune absorption d'eau
Keine Wasseraufnahme
Водонепроницаема



PERCHÈ RESISTE ALL'ATTACCO CHIMICO

Resistance to chemical attack
Résistance à l'attaque chimique
Säure- und Laugenbeständigkeit
Устойчива к бытовым химикатам

19mm come?

HOW? COMMENT? WIE? KAK?

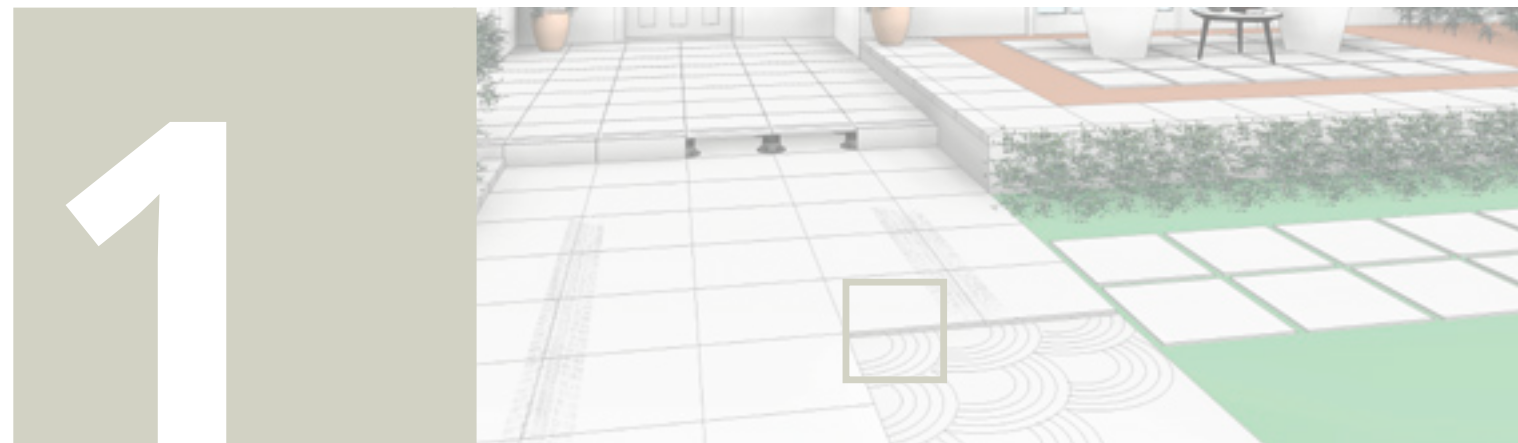

POSA A COLLA SU MASSETTO

LAYING WITH GLUE FOR CARRIAGEABLE PATH.
POSE À LA COLLE SUR CHAPE CARROSSABLE.
VERLEGUNG MIT KLEBER.
ТРАДИЦИОННАЯ УКЛАДКА НА КЛЕЙ

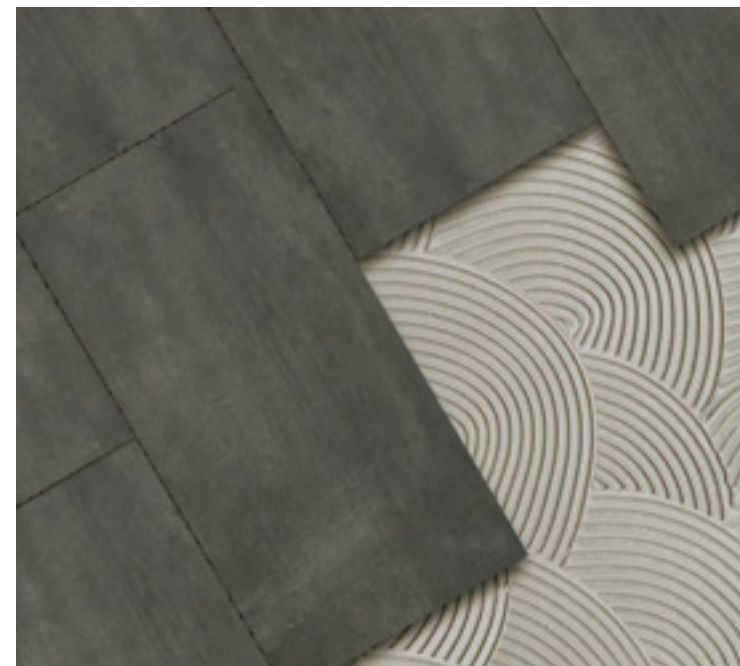

All'interno di aree urbane, la posa su massetto rappresenta la scelta ottimale per realizzare zone di parcheggio, marciapiedi, percorsi pedonali e ciclabili, garantendo al tempo stesso praticità, pulizia, estetica e sicurezza.

In urban areas, laying on concrete beds is the best choice to create parking areas, sidewalks, footpaths and cycle tracks, guaranteeing a result that is practical, clean, beautiful and safe all at the same time.

En zone urbaine, la pose sur chape est un choix optimal pour réaliser des aires de stationnement, des trottoirs, des parcours piétons et cyclables, garantissant à la fois praticité, propreté, esthétique et sécurité.

Die traditionelle Verlegung erlaubt eine maximale Nutzung der hohen Bruchfestigkeit und eignet sich ideal für die Gestaltung befahrbarer Bodenbeläge. Die Oberfläche nimmt keinen Schmutz auf und absorbiert keine Flecken und ist daher extrem reinigungsfreundlich.

В городских зонах укладка на стяжку является оптимальным выбором для строительства стоянок, тротуаров, пешеходных и велосипедных дорожек, гарантируя практичность, чистоту, эстетику и безопасность.

19 come? mm

HOW? COMMENT? WIE? KAK?

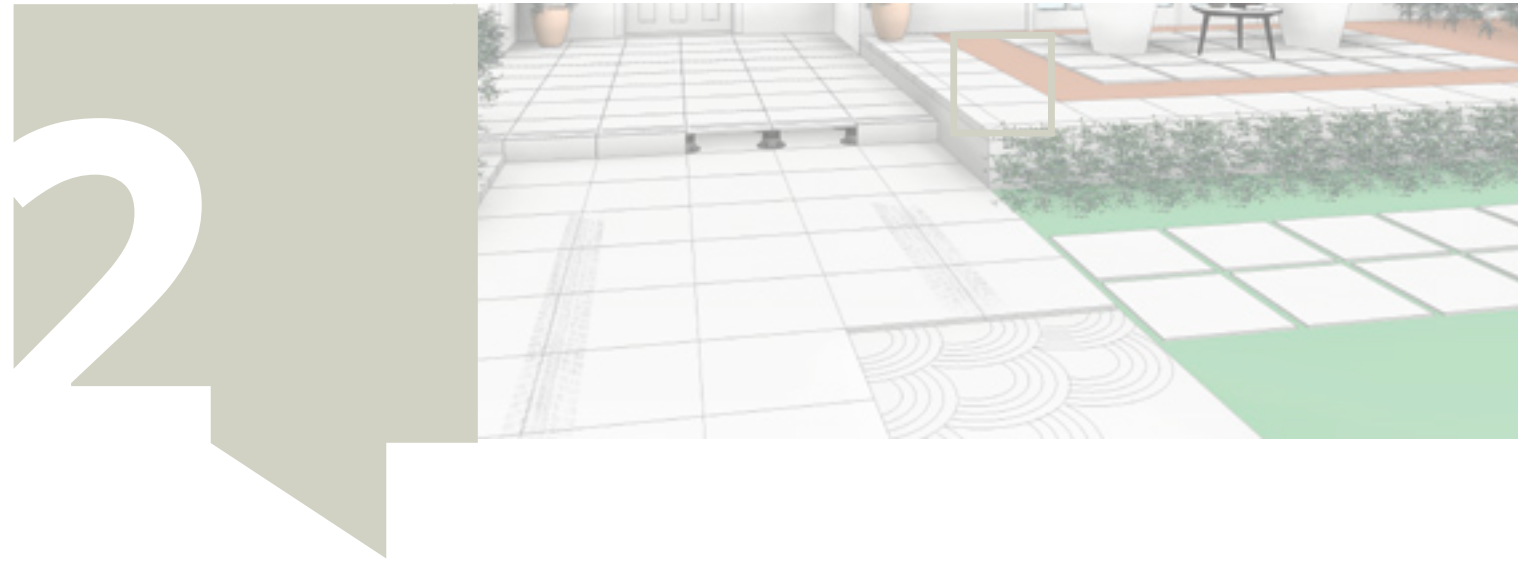

FLOTTANTE SU SABBIA E GHIAIA

DRY INSTALLATION ONTO GRAVEL OR SAND.
POSE À SEC SUR GRAVIER OU SABLE.
TROCKENVERLEGUNG IN SPLITT ODER
AUF SANDBETT
СУХАЯ УКЛАДКА НА
ПЕСОК ИЛИ ЩЕБЕНЬ.

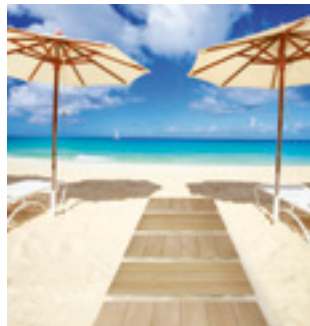

Per creare camminamenti pedonali, percorsi di raccordo e aree di sosta, è possibile posare il materiale direttamente su ghiaia o sabbia. I differenti metodi di posa consentono di realizzare ambienti articolati e garantire uniformità visiva anche in presenza di sottofondi diversi.
To create pedestrian walkways, linking paths and waiting areas, the material can be laid directly onto gravel or sand. The different laying methods allow complex surroundings to be created and the visual uniformity to be guaranteed even with different underlayers.
Pour créer des allées piétonnes, des parcours de raccordement et des aires de stationnement, le matériau peut être posé directement sur sable ou gravier. Les différents modes de pose permettent de réaliser des espaces structurés et garantissent l'uniformité visuelle, même en présence de supports différents.
Für die Gestaltung von Gehwegen, Verbindungsstrecken und Aufenthaltsbereichen besteht die Möglichkeit, das Material direkt auf Kies oder Sand zu verlegen. Die unterschiedlichen Verlegungsmethoden erlauben die Einrichtung artikulierter Bereiche und garantieren auch bei verschiedenartigen Untergründen eine gleichmäßige Optik.

Для строительства пешеходных дорожек, выездов и стоянок материал можно укладывать непосредственно на щебень или песок. Различные методы укладки позволяют использовать плиты в разных условиях и гарантировать зрительную однородность даже при наличии разнотипных оснований.

19 come? mm

HOW? COMMENT? WIE? KAK?

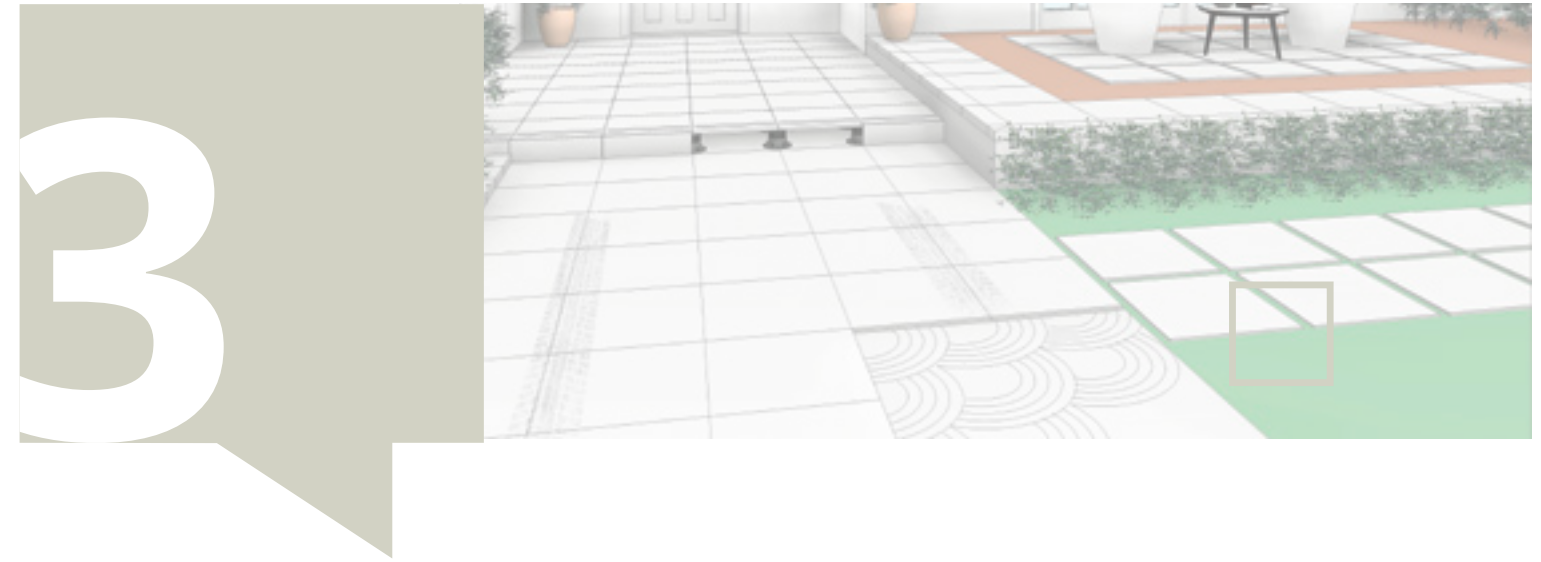

FLOTTANTE SU TERRA

DRY INSTALLATION ONTO GRASS.
POSE À SEC SUR GAZON.
TROCKENVERLEGUNG AUF RASEN.
СУХАЯ УКЛАДКА НА ТРАВУ.

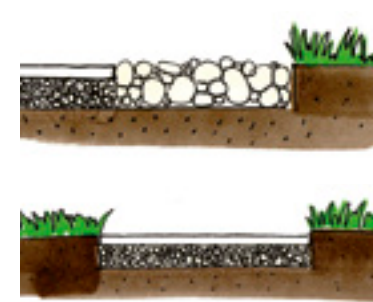

Con la posa a secco su erba si possono creare percorsi che si inseriscono con eleganza all'interno di parchi pubblici e giardini privati. Questa tecnica di posa è semplice, ecologica e non richiede l'intervento di personale professionista.

With dry laying on grass, you can create paths that blend elegantly into public parks and private gardens. This laying technique is simple, environmentally friendly, and does not require the intervention of professional operators.

La pose à sec sur gazon permet de créer des parcours qui s'insèrent avec élégance dans les parcs publics et les jardins privés. Simple et écologique, cette technique de pose ne requiert pas l'intervention d'un professionnel.

Durch Trockenverlegung auf Gras lassen sich Strecken gestalten, die sich elegant in öffentliche Parkanlagen wie auch Privatgärten fügen. Diese Verlegungstechnik ist einfach, ökologisch und verlangt kein Fachpersonal.

Благодаря сухой укладке на траву можно создавать такие дорожки, которые элегантно впишутся в городские парки и частные сады. Эта техника укладки является простой, экологичной, не требующей услуг специализированного персонала.

19 come?

mm

19 MM

HOW? COMMENT? WIE? KAK?

4

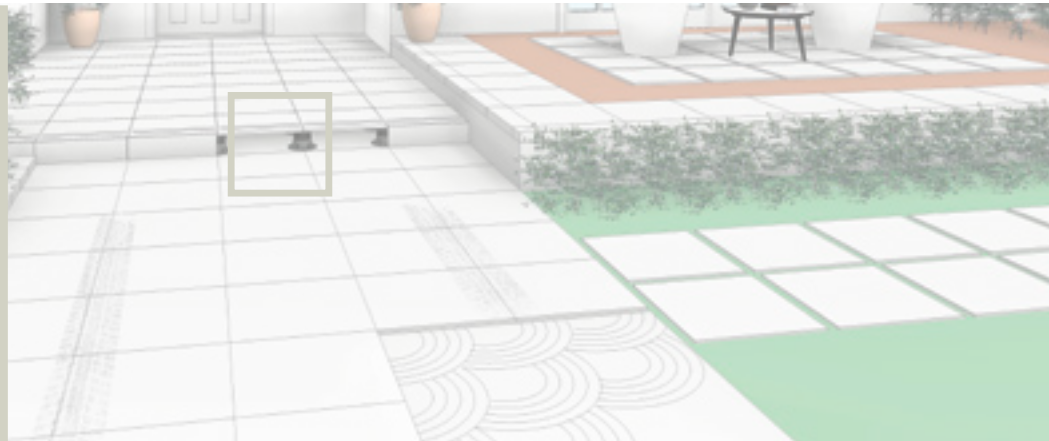

FLOTTANTE SOPRAELEVATA E DRENANTE

INSTALLATION USING A DRAINING RAISED STRUCTURE.
POSE SURÉLEVÉE ET DRAINANTE.
DOPPELBODENVERLEGUNG AUF STELZLAGERN MIT DRAINAGE.
УКЛАДКА ФАЛЬШПОЛОВ С ДРЕНАЖОМ.



La posa sopraelevata è ottimale per ogni necessità di pavimentazione in presenza di cavi o tubi non inseriti nel massetto e per ogni necessità di ispezionabilità degli stessi o del sottofondo, inoltre garantisce il drenaggio delle acque piovane nelle pavimentazioni esterne.

Raised laying is excellent whenever there is a need for flooring with the cables or pipes not inserted in the bed and where these, or the underlayer, need to be accessed for inspection; it also guarantees the draining of rainwater in outdoor flooring.

La pose surélevée est un choix optimal pour la réalisation de revêtements de sol en présence de câbles ou de conduites hors chape. Elle laisse la possibilité d'inspecter ces derniers ou le support, et garantit le drainage des eaux de pluie dans les sols extérieurs.

Die Doppelbodenverlegung ist eine optimale Lösung für jede Bodengestaltung wo Kabel oder Rohrleitungen nicht in den Estrich eingebettet sind und wo Kabel, Rohrleitungen oder Untergründe inspektionierbar bleiben müssen. Außerdem garantieren Doppelböden bei externen Bodenbelägen die Regenwasserdränage.

Фальшпол отлично подходит для любых необходимостей настила полов при наличии кабелей или труб, которые не включены в стяжку, а также для любых необходимостей осмотра как их самих, так и основы. Кроме того, гарантируется дренаж дождевой воды на наружных полах.

PERCHÈ CONSENTE IL PASSAGGIO DI IMPIANTI ELETTRICI E IDRICI.

Because it allows the passage of electrical and plumbing installations.
Parce qu'il permet le passage des équipements électriques et d'eau.
Weil er die Durchführung von Strom- und Wasseranlagen erlaubt.
Потому, что позволяет прокладывать электрические и водопроводные системы.

PERCHÈ GARANTISCE IL DRENAGGIO DELLE ACQUE PIOVANE.

Because it allows stormwater drainage.
Parce qu'il garantit le drainage de l'eau de pluie.
Garantiert die Ableitung des Regenwassers.
Потому, что он гарантирует дренаж дождевой воды.

PERCHÈ RISOLVE I PROBLEMI DI DISLIVELLO.

Because it solves floor unevenness.
Parce qu'il résout les problèmes de dénivellation.
Weil er bei Höhenunterschieden eine Lösung ist.
Потому, что решает проблемы перепада уровня.

PERCHÈ È FACILE DA POSARE.

Because it is easy to lay down.
Parce qu'il est facile à poser.
Weil er leicht zu verlegen ist.
Потому, что он прост в укладке.

PERCHÈ È REMOVIBILE.

Because it is removable.
Parce qu'il est amovible.
Weil er entfernbar ist.
Потому, что он съемный и осматриваемый.

PERCHÈ È ISPEZIONABILE FACILMENTE.

Because it can be easily inspected.
Parce qu'il est facile à vérifier.
Weil er einfach inspektionierbar ist.
Потому, что он легко осматривается.

PERCHÈ È RIUTILIZZABILE.

Because it is reusable.
Parce qu'il est réutilisable.
Weil er wiederverwendbar ist.
Потому, что он подлежит повторному использованию.

CARATTERISTICHE TECNICHE SUPPORTI

Support technical features. Caracteristiques techniques support.
Technische eigenschaften tragstruktur. технические характеристики опор.



SUPPORTI REALIZZATI CON MATERIALE TOTALMENTE RICICLABILE

Supports made with totally recycled material.
Supports réalisés avec matériel entièrement recyclable
Stelzlager aus recycelbarem Material.
Подставка полностью реализована из вторичного сырья



RESISTENTI ALLE SOLUZIONI ACIDE E BASICHE

Resistant to acidic and basic solutions.
Résistant aux solutions acides et basiques
Saeure- und Laugenbeständig.
Устойчива к кислотным и щелочным растворам



RESISTENTE AGLI AGENTI ATMOSFERICI

Weather resistant.
Résistant à la désagrégation
Wetterbeständig.
Устойчива к атмосферным факторам



RESISTENTE A TEMPERATURE DA -30° A +120°

Temperature resistant from -30° to +120°.
Résistant à la température de -30° à +120°
Beständigkeit beim Temperaturschwankungen von -30° bis +120°.
Устойчива к перепадам температур от -30° до +120°

19 come?

mm

HOW? COMMENT? WIE? KAK?

19 MM

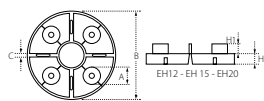

SUPPORTO FISSO (EH)
Fixed support (EH)
Support fixe (EH)
Feste tragstruktur (EH)
фиксированная опора (EH)
EH12= h 12 mm



SUPPORTO REGOLABILE (NM)
Adjustable support (NM)
Support réglable (NM)
Verstellbare tragstruktur (NM)
регулируемая опора (NM)
NM1= h 25/40 mm
NM2= h 40/70 mm
NM3= h 60/100 mm



SUPPORTO AUTOLIVELLANTE (SE)
Self-levelling support (SE)
Support autonivelant (SE)
Selbthnivellierende tragstruktur (SE)
самовыравнивающаяся опора (SE)
SE1= h 37/50 mm
SE2= h 50/75 mm
SE3= h 75/120 mm
SE4= h 120/170 mm

AVVERTENZE PER LA POSA SOPRAELEVATA

IMPORTANT NOTES FOR FLOATING INSTALLATION.

Per garantire la massima sicurezza del sistema sopraelevato si consiglia l'uso di un ulteriore supporto posizionato al centro della lastra. Tale soluzione definisce una distribuzione uniforme dei carichi e genera la massima resistenza della superficie calpestabile.

To ensure maximum mechanical performance and safety of the raised floor/paving, we suggest you to add one more pedestal positioned at the centre of the raised tile. This measure ensures uniform load distribution and maximum strength of the walkable surface.

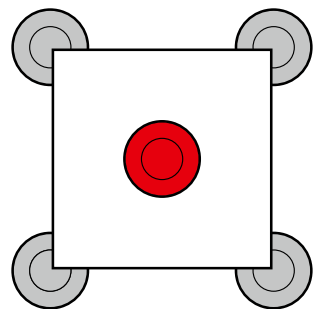

INCIDENZA DEI SUPPORTI AL M²

NUMBER OF PEDESTALS PER M²

Dimensione lastra Tile size	20 cm	30 cm	40 cm	45 cm	50 cm	60 cm	70 cm	75 cm	80 cm	90 cm	100 cm
20 cm	25	16,67	12,5	11,11	10	8,33	14,29	13,33	12,5	11,11	10
30 cm	16,67	11,11	8,33	7,41	6,67	5,56	9,52	8,89	8,33	7,41	6,67
40 cm	12,5	8,33	6,25	5,56	5	4,17	7,14	6,67	6,65	5,56	5
45 cm	11,1	7,41	5,56	4,94	4,44	3,7	6,35	5,63	5,56	4,94	4,44
50 cm	10	6,67	5	4,44	4	3,33	5,71	5,33	5	4,44	4
60 cm	8,3	5,56	4,17	3,7	3,33	2,78	4,76	4,44	4,17	3,7	3,33
70 cm	14,29	9,52	7,14	6,35	5,71	4,76	4,08	3,81	3,57	3,17	2,86
75 cm	13,33	8,89	6,67	5,93	5,33	4,44	3,81	3,56	3,33	2,96	2,67
80 cm	12,5	8,33	6,25	5,56	5	4,17	3,57	3,33	6,25	5,56	5
90 cm	11,11	7,41	5,56	4,94	4,44	3,7	3,17	2,96	5,56	4,94	4,44
100 cm	10	6,67	5	4,44	4	3,33	2,86	2,67	5	4,44	4
120 cm	8,33	5,56	4,17	3,7	3,33	2,78	2,38	2,22	4,17	3,7	3,33
140 cm	14,29	9,52	7,14	6,35	5,71	4,76	2,04	1,9	3,57	3,17	2,86

NB: questa tabella è un puro calcolo matematico e non tiene conto di tutte le variabili di cantiere, pertanto i valori di incidenza sono indicativi e consigliamo di rivolgersi sempre ai nostri tecnici.

NB: this table is a pure mathematical calculation and does not take into account all the site variables so the incidence values are indicative and we recommend always contacting our technicians.

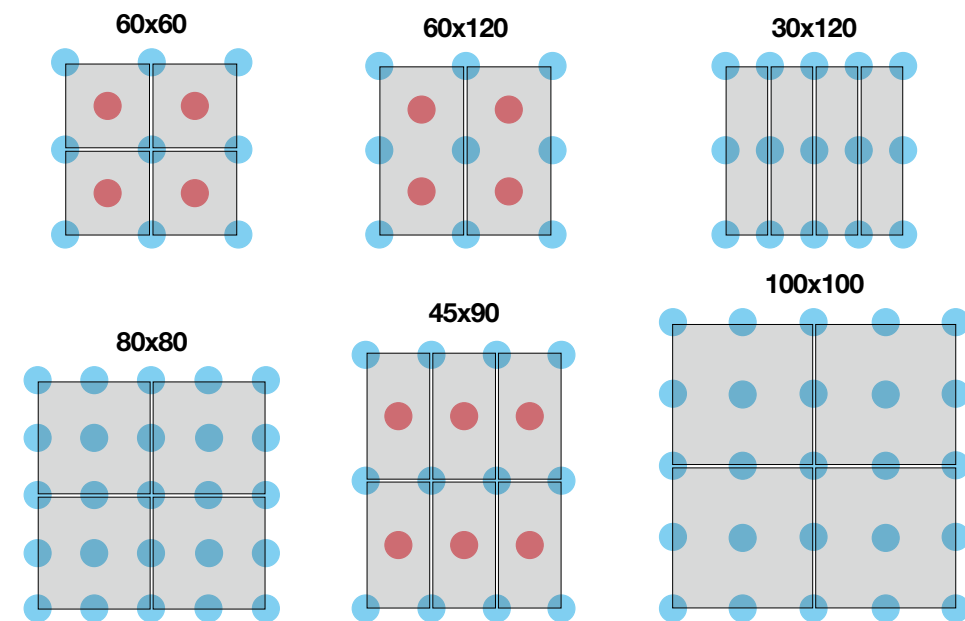

MODULARE 10

1 - 20x20...14,3%
2 - 20x40...28,6%
3 - 40x40...57,1%

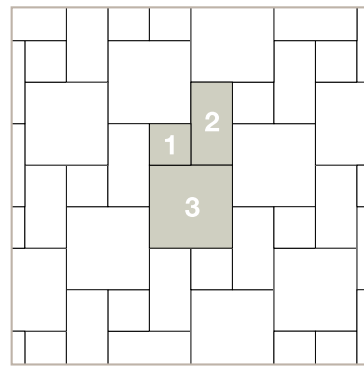
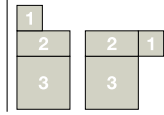
**DUOMO****RIABITA IL COTTO****MODULARE 19**

1 - 20x20 11,1%
2 - 20x40 44,45%
3 - 40x40 44,45%

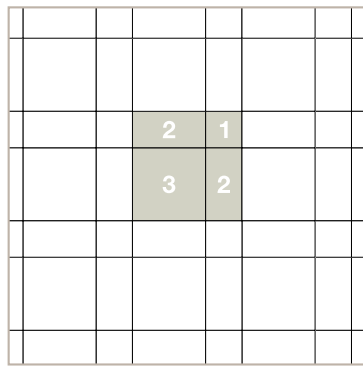
**DUOMO****RIABITA IL COTTO****MODULARE 26**

1 - 20x40 14,3%
2 - 40x40 28,6%
3 - 40x80 57,1%

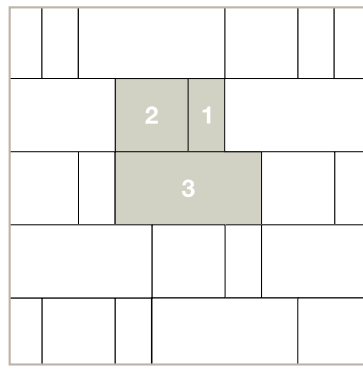
**DUOMO****RIABITA IL COTTO****MODULARE 27**

1 - 20x20 6,67%
2 - 20x40 13,34%
3 - 40x40 26,66%
4 - 40x80 53,33%

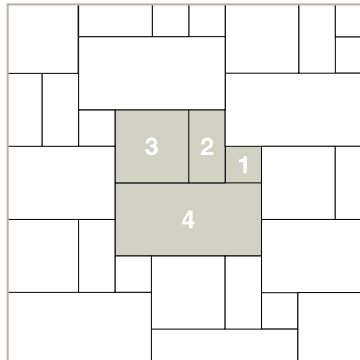
**DUOMO****RIABITA IL COTTO****MODULARE 30**

1 - 30x120 60%
2 - 20x120 40%

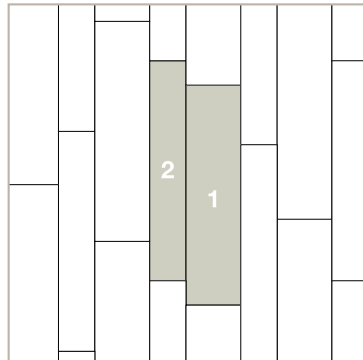
**ÀCANTO****I ROVERI****NEWPORT****NORWAY****MODULARE 40**

1 - 30x60 14,3%
2 - 60x60 28,5%
3 - 60x120 57,2%

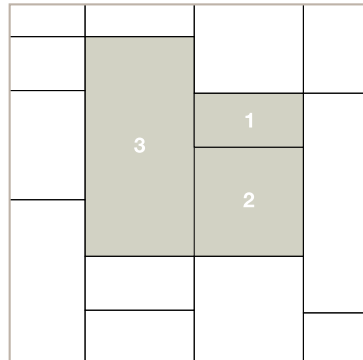
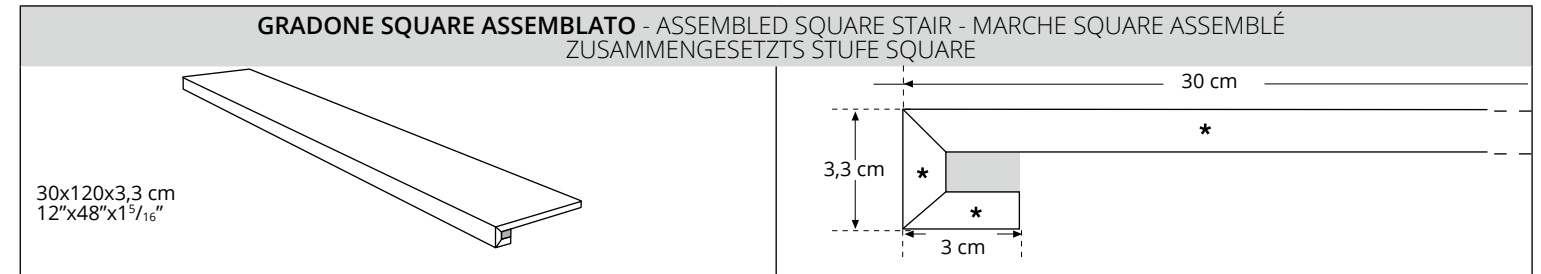
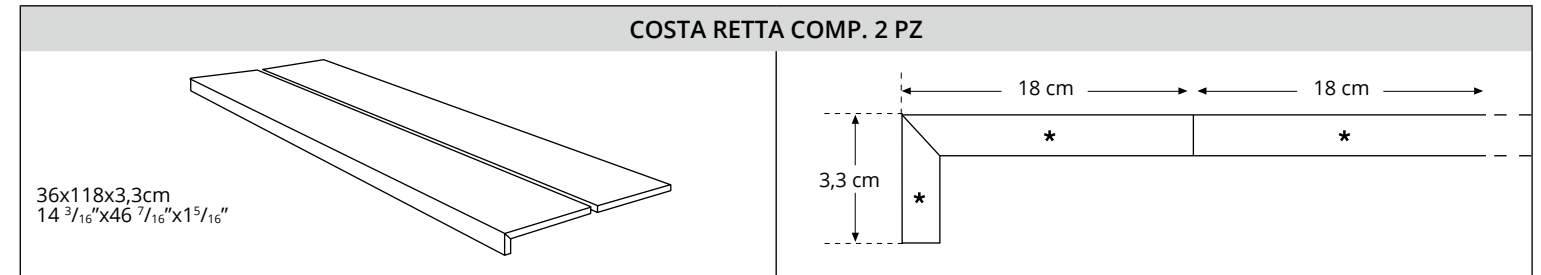
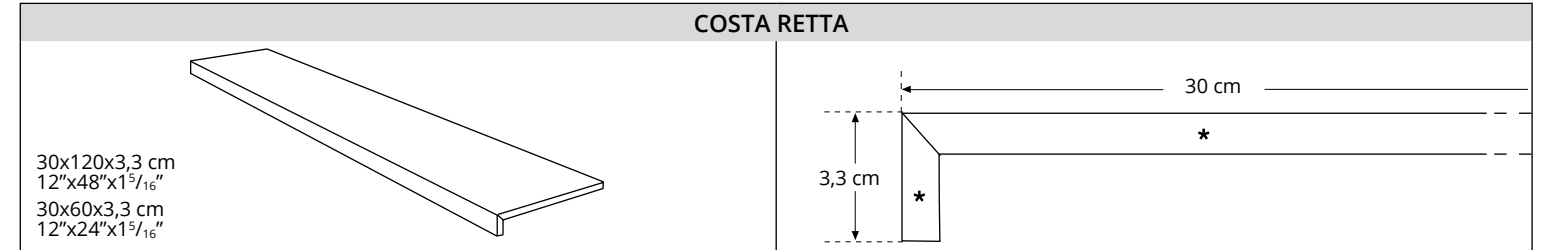
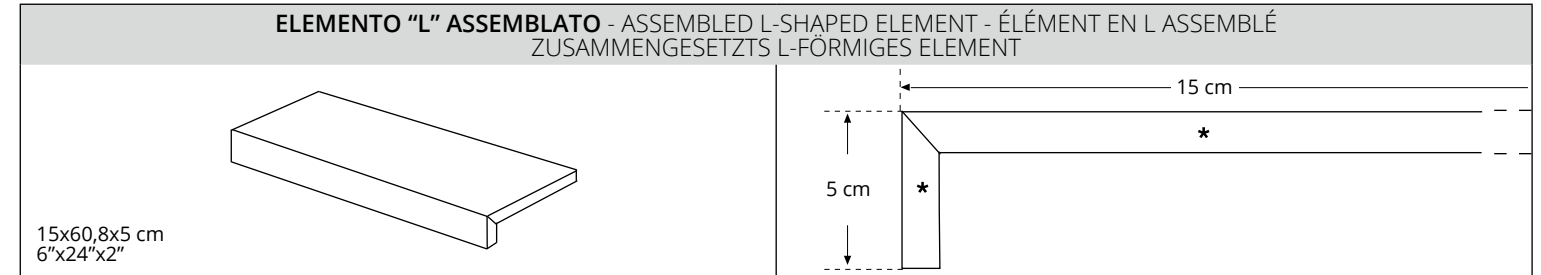
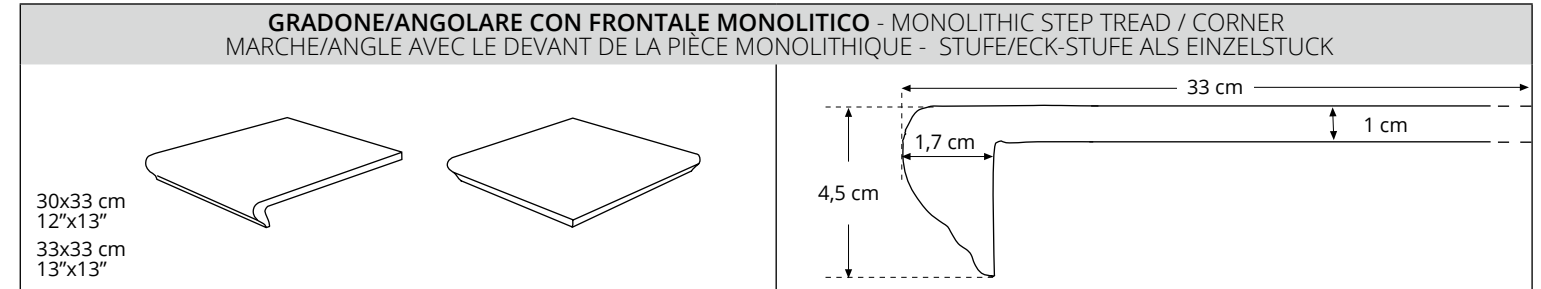
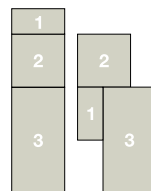
**COSTRUIRE****EVOCA****FOSSIL RETT****MATERICA****PROMENADE****STUDIO 50****TRAVERTINI DUE RETT**

* Spessore piastrella - Tile Thickness - Epaisseur du carreau - Stärke der Fliese

PEZZI SPECIALI E FONDO POSSONO DIFFERIRE IN TERMINI DI TONALITÀ, IL BORDO PUÒ PRESENTARE STRATIFICAZIONI DI TONALITÀ DIVERSE.

SPECIAL PIECES AND FIELD TILES MAY COME IN DIFFERENT SHADES, THE SLAB'S EDGE MAY SHOW LAYERS OF DIFFERING HUES.
IL PEUT Y AVOIR DES DIFFÉRENCES DE TONALITÉS ENTRE LES PIÈCES SPÉCIALES ET LE FOND, LE BORD POURRAIT PRÉSENTER DES STRATIFICATIONS DE TONALITÉS DIFFÉRENTES.
DIE FORMTEILE KÖNNEN FARBLICH VON DER GRUNDPLATTE ABWEICHEN, IHRE KANTEN KÖNNEN SCHICHTUNGEN IN UNTERSCHIEDLICHEN FARBTÖNEN AUFWEISEN.

* La posa modulare è consigliata con una fuga di 4 mm, 2 mm per i prodotti rettificati.

We recommend modular laying with a 4 mm 3/16" joint, and a 2 mm joint for rectified products.

La pose modulaire est conseillée avec un joint de 4 mm, 2 mm pour les produits rectifiés.

Die Modulverlegung wird mit einer Mindestfuge von 4 mm empfohlen, 2 mm fuer rektifizierte Produkte.

При модульной укладке рекомендуется шов в 4 мм, 2 мм для укладки модулем ректифицированной плитки.

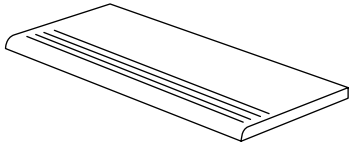
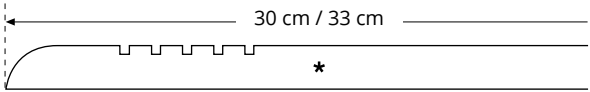
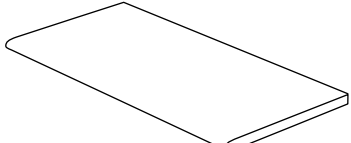
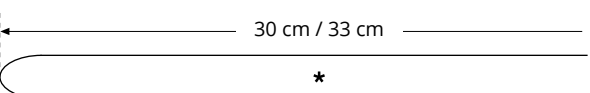
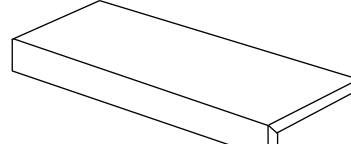
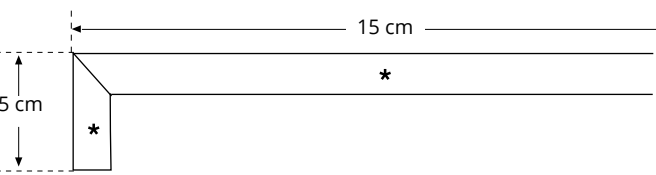
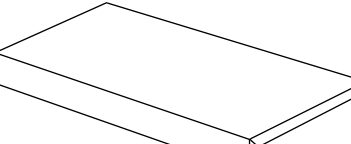
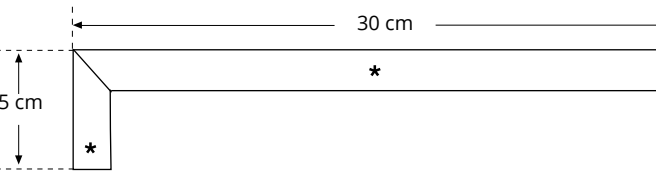
STEP MOLATO	
<p>30x60 cm 12"x24" 30x120 cm 12"x48" 33x100 cm 13"x40"</p> 	
STEP TORATO	
<p>30x60 cm 12"x24" 30x120 cm 12"x48" 33x100 cm 13"x40"</p> 	
ELEMENTO "L" ASSEMBLATO - ASSEMBLED L-SHAPED ELEMENT - ÉLÉMENT EN L ASSEMBLÉ ZUSAMMENGESETZTS L-FÖRMIGES ELEMENT	
<p>15x60x5 cm 6"x24"x2" 15x100x5 cm 6"x40"x2"</p> 	
COSTA RETTA	
<p>30x60x5 cm 12"x24"x2" 30x100x5 cm 12"x40"x2"</p> 	

* Spessore piastrella - Tile Thickness - Epaisseur du carreau - Stärke der Fliese

PEZZI SPECIALI E FONDO POSSONO DIFFERIRE IN TERMINI DI TONALITÀ, IL BORDO PUÒ PRESENTARE STRATIFICAZIONI DI TONALITÀ DIVERSE.

SPECIAL PIECES AND FIELD TILES MAY COME IN DIFFERENT SHADES, THE SLAB'S EDGE MAY SHOW LAYERS OF DIFFERING HUES.
IL PEUT Y AVOIR DES DIFFÉRENCES DE TONALITÉS ENTRE LES PIÈCES SPÉCIALES ET LE FOND, LE BORD POURRAIT PRÉSENTER DES STRATIFICATIONS DE TONALITÉS DIFFÉRENTES.
DIE FORMTEILE KÖNNEN FARBLICH VON DER GRUNDPLATTE ABWEICHEN, IHRE KANTEN KÖNNEN SCHICHTUNGEN IN UNTERSCHIEDLICHEN FARBTÖNEN AUFWEISEN.

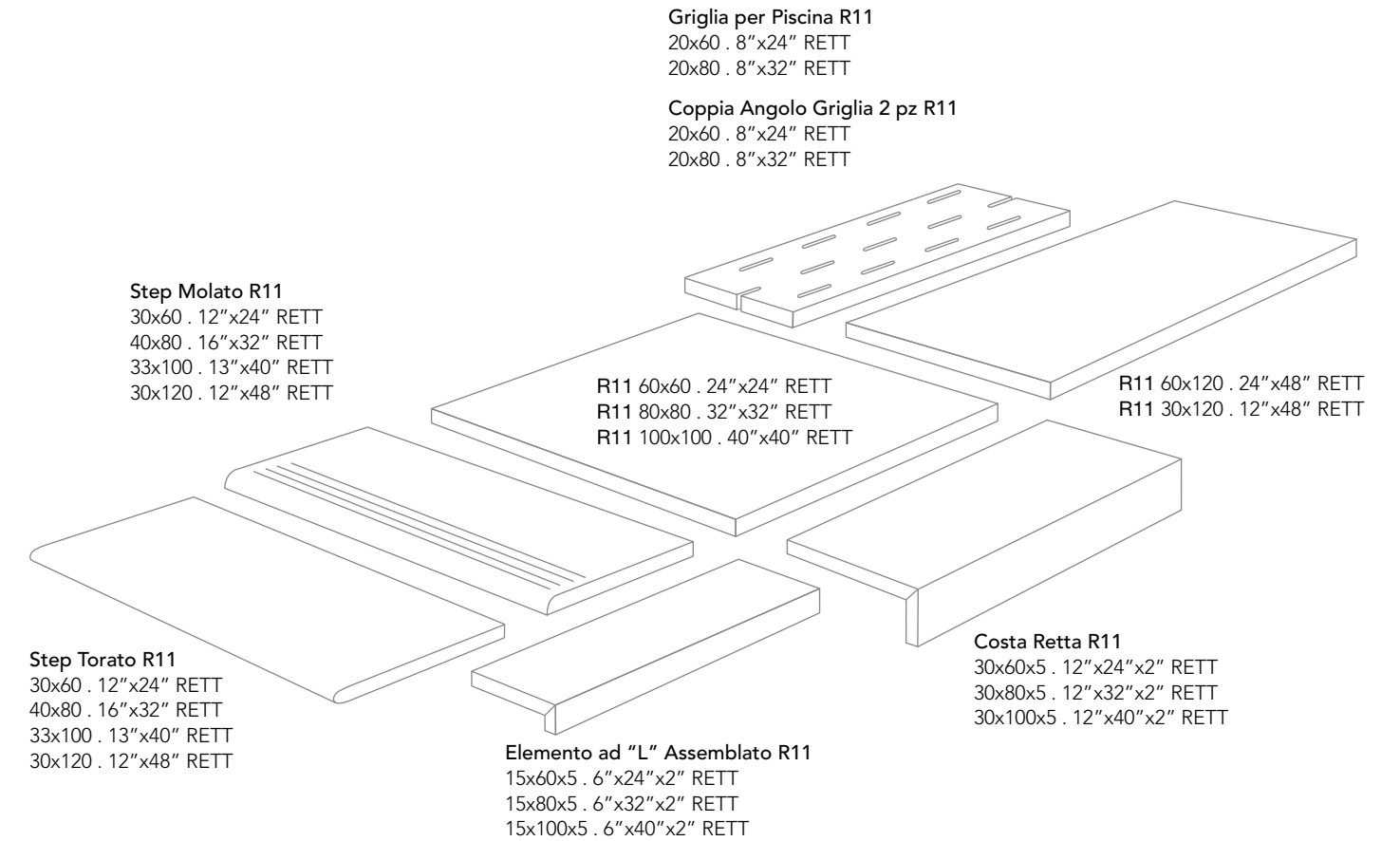

PEZZI SPECIALI E FINITURE DISPONIBILI SU RICHIESTA
SPECIAL TRIMS AND FINISHES AVAILABLE ON DEMAND.
PIÈCES SPÉCIALES ET FINITIONS DISPONIBLES SUR DEMANDE.
FORMSTÜCKE UND SONDERANFERTIGUNGEN AUF ANFRAGE.

PEZZI SPECIALI E FONDO POSSONO DIFFERIRE IN TERMINI DI TONALITÀ, IL BORDO PUÒ PRESENTARE STRATIFICAZIONI DI TONALITÀ DIVERSE.

SPECIAL PIECES AND FIELD TILES MAY COME IN DIFFERENT SHADES, THE SLAB'S EDGE MAY SHOW LAYERS OF DIFFERING HUES.
IL PEUT Y AVOIR DES DIFFÉRENCES DE TONALITÉS ENTRE LES PIÈCES SPÉCIALES ET LE FOND, LE BORD POURRAIT PRÉSENTER DES STRATIFICATIONS DE TONALITÉS DIFFÉRENTES.
DIE FORMTEILE KÖNNEN FARBLICH VON DER GRUNDPLATTE ABWEICHEN, IHRE KANTEN KÖNNEN SCHICHTUNGEN IN UNTERSCHIEDLICHEN FARBTÖNEN AUFWEISEN.

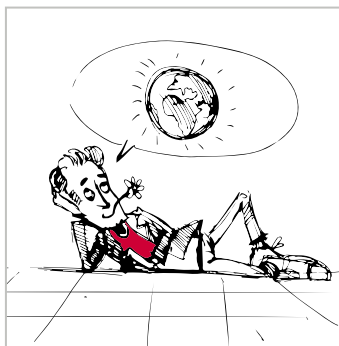
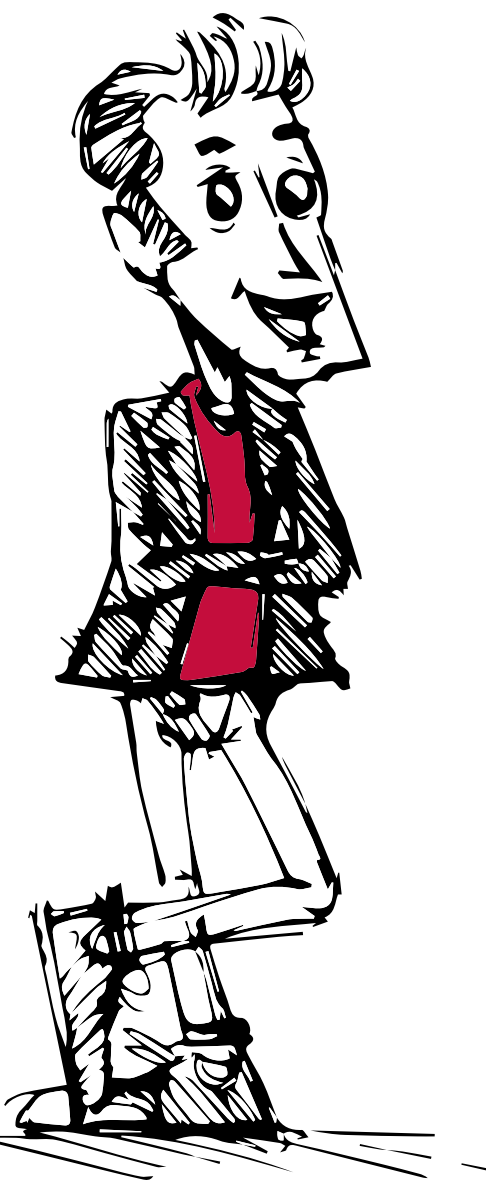

LA CERAMICA È NATURALE, NON CONTIENE PLASTICA ED È COMPLETAMENTE RICICLABILE.

Ceramic is natural, contains no plastic and is completely recyclable.

La céramique ne contient pas de plastique, elle est naturelle et entièrement recyclable.

Keramik ist natürlich, sie enthält keine Kunststoffe und ist vollständig recycelbar.

Керамика - это натуральный, не содержащий пластмассы материал, полностью подлежащий повторной переработке.



È IGIENICA, ANALLERGICA, NON TRATTIENE LO SPORCO, I BATTERI ED È ASSOLUTAMENTE INODORE.

It is hygienic, hypoallergenic, does not retain dirt and bacteria and is entirely odourless.

Hygiénique, hypoallergénique et absolument inodore, elle ne retient ni la saleté ni les bactéries.

Sie ist hygienisch, anallergisch, schmutz- und bakterienabweisend und absolut geruchlos.

Она гигиенична, не вызывает аллергию, не задерживает грязь, бактерии и не имеет никаких запахов.



RISPETTA L'AMBIENTE E LA SALUTE PERCHÈ PRODOTTA IN MODO CONFORME ALLE PIÙ RIGOROSE NORMATIVE EUROPEE ED INTERNAZIONALI.

It is eco-friendly and health-friendly because it is produced in compliance with the strictest European and international regulations.

Elle respecte l'environnement et la santé parce qu'elle est produite conformément aux normes européennes et internationales les plus strictes.

Sie schadet weder der Umwelt noch der Gesundheit, da sie nach den strengsten europäischen und internationalen Vorschriften hergestellt wird.

Она защищает окружающую среду и здоровье, потому что производится в соответствии с самыми строгими европейскими и международными нормами.



UN PAVIMENTO IN CERAMICA DURA A LUNGO, SI PULISCE FACILMENTE ED È SEMPRE COME NUOVO.

A ceramic floor is long-lasting, easy to clean and is always as good as new.

Un sol en céramique dure longtemps, se lave facilement et reste toujours comme neuf.

Ein Keramikboden hält lange, ist leicht zu reinigen und immer wie neu.

Керамический пол долговечен, легко очищается и всегда выглядит как новый.

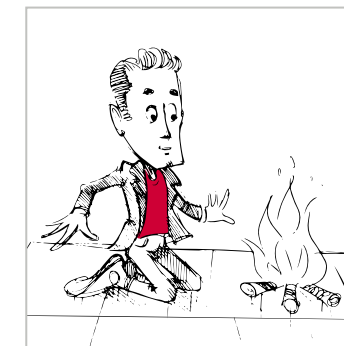

LA CERAMICA NON BRUCIA, IN CASO DI INCENDIO NON RILASCIAMOSTANZESUBSTANZENOCIVE NÈ PER L'UOMO NÈ PER L'AMBIENTE.

Ceramic does not burn, in the event of a fire it does not release substances harmful to man or to the environment.

La céramique ne brûle pas, en cas d'incendie elle ne dégage pas de substances nocives pour l'homme ou l'environnement.

Keramik brennt nicht, im Brandfall setzt sie keine gesundheits- oder umweltschädlichen Stoffe frei.

Керамика не горит, в случае пожара она не выделяет вредных веществ как для человека, так и для окружающей среды.



NON SI DEFORMA, NON GELA E RESISTE AI DETERGENTI CHIMICI PIÙ AGGRESSIVI

It does not warp, does not freeze and is not damaged by aggressive chemical detergents.

Elle ne se déforme pas, ne gèle pas et résiste aux détergents chimiques les plus agressifs.

Sie verformt sich nicht, gefriert nicht und hält den aggressivsten chemischen Reinigungsmitteln stand.

Она не деформируется, не замерзает и выдерживает воздействие самых агрессивных химических моющих средств.

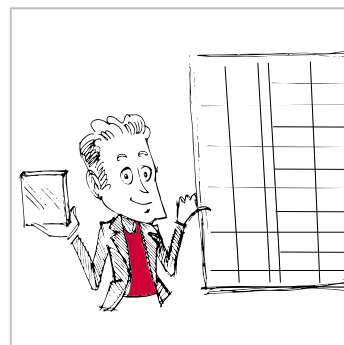

È VERSATILE, IDEALE SU PAVIMENTI E PARETI, È DISPONIBILE IN MOLTISSIMI FORMATI E SUPERFICI

It is versatile, ideal for floors and walls, and is available in many sizes and finishes.

Elle est polyvalente, idéale sur les sols et les murs, et disponible dans de très nombreux formats et surfaces.

Sie ist vielseitig, ideal für Böden und Wandverkleidungen und in unzähligen Formaten und Oberflächen erhältlich.

Она универсальна, отлично подходит для настила полов и облицовки стен, представлена в большом ассортименте форматов и отделки.



UN PAVIMENTO IN CERAMICA SI POSA FACILMENTE... NEI NEGOZI, NEGLI UFFICI, NEI RISTORANTI E IN OGNI TIPO DI LOCALE.

A ceramic floor is easy to lay ... in shops, offices, restaurants and in any type of premises.

Un sol en céramique est très facile à poser... dans les magasins, les bureaux, les restaurants et autres établissements en tout genre.

Ein Keramikboden kann problemlos leicht verlegt werden... in Geschäften, Büros, Restaurants und in allen Arten von Lokalen.

Керамический пол легко настиляется в магазинах, в офисах, в ресторанах и в помещениях любого типа.



MA SOPRATTUTTO È BELLISSIMA PERCHÈ AUTENTICA E SICURA, CAPACE DI DONARE STILE E VALORE AD OGNI AMBIENTE.

But, above all, it is beautiful because it is authentic and safe, with the capacity to bring style and value to any environment.

Elle est surtout très belle car authentique et sûre, capable de donner du style et de la valeur à tout espace.

Und sie ist vor allem wunderschön, weil sie authentisch und sicher ist und jedem Ambiente Stil verleiht und dabei seinen Wert steigert.



NATURALMENTE SCELGO LA CERAMICA

NATURALLY, I CHOOSE CERAMIC!
JE CHOISIS NATURELLEMENT LA CÉRAMIQUE!
ICH WÄHLE NATÜRLICH KERAMIK!
ЕСТЕСТВЕННО, Я ВЫБИРАЮ КЕРАМИКУ!

UN SISTEMA DI SUPERFICI AFFIDABILE, VERSATILE E COMPLETO.

Il programma di superfici del Gruppo Romani è uno strumento completo per la progettazione degli spazi sia domestici che commerciali. Le caratteristiche tecniche dei differenti spessori del gres porcellanato uniti a differenti metodi di posa, consentono di realizzare ambienti con esigenze complesse. Tanti vantaggi pratici che si sommano alla ricchezza di gamma di pezzi speciali dedicati a piscine e pavimenti sopraelevati. Ogni esigenza ha una risposta che risolve tecnicamente ed esteticamente le tematiche più complesse per elaborare spazi bellissimi, sicuri ed eterni.

THE RELIABLE, VERSATILE AND COMPLETE SURFACES SYSTEM.

The Gruppo Romani surfaces programme is a complete design tool for domestic and commercial spaces. The technical features of porcelain stoneware in different thicknesses combined with different installation methods, make it possible to create environments to meet complex requirements. A host of practical advantages, backed up by a vast range of trims for swimming pools and floating floors. Each need has an answer that provides technical and aesthetic solutions in the most complex applications to create beautiful, safe and indestructible spaces.

UN SYSTÈME DE REVÊTEMENT FIABLE, POLYVALENT ET COMPLET.

Le programme de revêtements du Gruppo Romani est un instrument complet pour la conception des espaces aussi bien domestiques que commerciaux. Les caractéristiques techniques des différentes épaisseurs du grès cérame unies aux différentes méthodes de pose permettent la réalisation d'environnements aux exigences complexes. Ces avantages pratiques s'ajoutent à la richesse de la gamme des pièces spéciales dédiées aux piscines et aux sols surélevés. Chaque exigence obtient une réponse qui résout aussi bien techniquement qu'esthétiquement les problèmes les plus complexes, afin d'élaborer des espaces magnifiques, sûrs et éternels.

EIN ZUVERLÄSSIGES, VIELSEITIGES UND KOMPLETTES OBERFLÄCHENSYSTEM.

Das Oberflächenprogramm von Gruppo Romani ist ein komplettes Instrument, mit dem man sowohl Wohn- als auch Geschäftsräume gestalten kann. Die technischen Eigenschaften der verschiedenen Stärken von Feinsteinzeug ermöglichen zusammen mit den unterschiedlichen Verlegungsmethoden die Gestaltung von Räumen, deren komplexe Anforderungen vollauf erfüllt werden. Unzählige praktische Vorteile, die eine breite Palette von Spezialstücken für Schwimmbäder und Doppelböden erweitern. Für jeden Bedarf gibt es eine Antwort, die auch die komplexesten Probleme technisch und optisch löst.

НАДЕЖНАЯ, УНИВЕРСАЛЬНАЯ И ПОЛНАЯ СИСТЕМА КЕРАМОГРАНИТНЫХ ПОВЕРХНОСТЕЙ.

Предложенная Gruppo Romani программа керамогранитных поверхностей - это комплексный инструмент для оформления как бытовых, так и коммерческих пространств. Технические характеристики керамогранита различной толщины наряду с разными методами укладки позволяют создавать интерьеры, удовлетворяющие сложные требования. Множество практических преимуществ дополняют широкий ассортимент специальных изделий для бассейнов и фальшполов. На любое требование находится ответ, решающий наиболее сложные технические и эстетические вопросы, создавая очень красивые, безопасные и долговечные пространства.

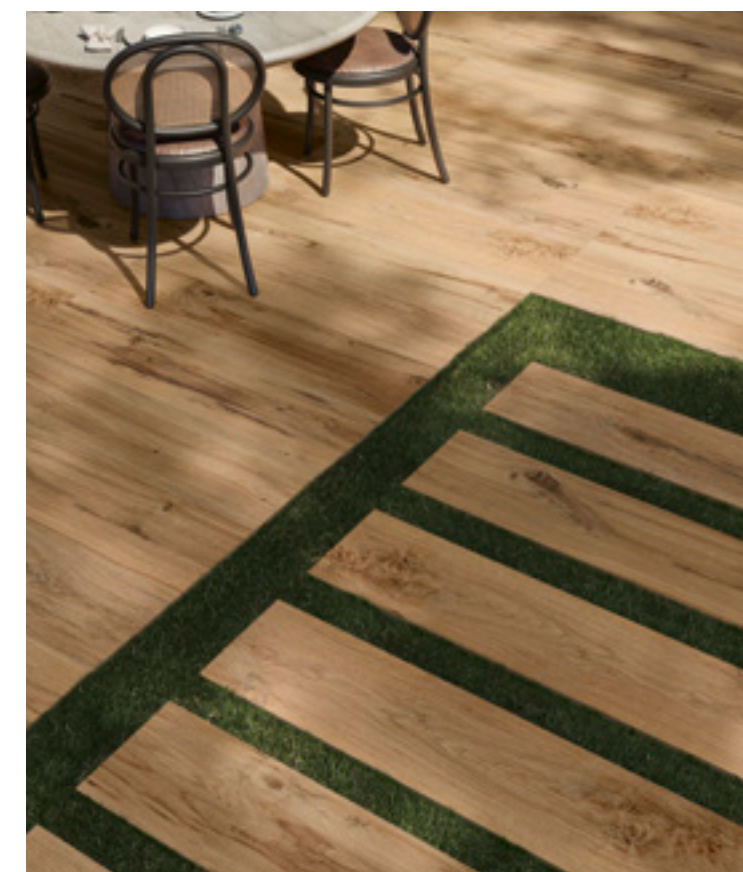



+ NON TEME GLI EVENTI ATMOSFERICI

*Completely weatherproof
Ne craint pas les événements climatiques
Witterungsfest
Не боится атмосферного воздействия*



NON ASSORBE ACQUA

*No water absorption
N'absorbe pas l'eau
Wasserfest
Не впитывает воду*



RESISTE AL GELO

*Frost resistance
Résiste au gel
Frostbeständig
Выдерживает низкие температуры*



RESISTE ALLO SHOCK TERMICO

*Thermal shock resistance
Résiste aux chocs thermiques
Thermoschockbeständig
Выдерживает тепловые перепады*



RESISTENZA TOTALE DEI COLORI ESPOSTI AL SOLE

*Color resistance to light
Résistance totale des couleurs exposées au soleil
Lichtecht
Абсолютная неизменность цветов на солнце*

+ È SICURO

*Safe / Sûr
Sicher / безопасность*



RESISTE ALLA SCIVOLOSITÀ

*Skid resistance
Résiste à la glissance
Rutschfest
Спротивление скольжению*



È IGNIFUGO

*Resistant to fire
Ignifuge
Feuerfest
Огнестойкость*

+ FORTE E RESISTENTE

*Strong and resistant
Solide et résistant
Stark und widerstandsfest
Прочность и устойчивость*

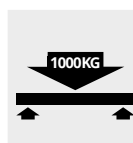

RESISTE ALLA FLESSIONE E ALLA FORZA DI ROTTURA

19 mm / 15 mm

*Modulus of rupture and breaking strength
Résiste à la flexion et à la force de rupture
Biege- und bruchfest
Стойкость на изгиб и разрушающее усилие*

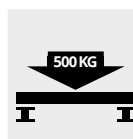

RESISTE AI CARICHI DI ROTTURA CON SUPPORTO PER PAVIMENTI SOPRAELEVATI

19 mm

*Charge of rupture with support
Résiste aux charges de rupture avec support
pour sols surélevés
Hält bruchlasten mit träger für doppelböden stand
Стойкость к разрушающим нагрузкам при
использовании опор для фальшпола*

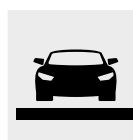

È CARRABILE

19 mm / 15 mm

*Drive-over
Carrossable
Befahrbar
Пригодность для движения
транспортных средств*



RESISTE AL CALPESTIO

*Resistant to foot traffic
Résiste au piétinement
Trittfest
Стойкость к хождению*

+ È PULITO

Clean / Propre / Sauber / Сохраняет чистоту



RESISTE ALLE MACCHIE

*Stainproof
Résiste aux taches
Fleckenbeständig
Стойкость к образованию пятен*



È FACILE DA PULIRE

*Easy to clean
Facile à nettoyer
Leicht zu reinigen
Легкость чистки*

+ NON TEME AGENTI ESTERNI

*Impervious to external agents
Ne craint pas les agents extérieurs
Resistent gegen äussere einwirkungen
Не боится воздействия окружающей среды*



RESISTE ALL'ATTACCO CHIMICO

*Resistance to chemical attack
Résiste aux attaques chimiques
Chemikalienbeständig
Стойкость к химическому воздействию*



RESISTE A MUFFE E MUSCHI

*Resistant to mold and moss
Résiste aux moisissures
et aux mousses
Schimmel- und moosresistent
Стойкость к образованию мха и плесени*



RESISTE AL SALE

*Resistant to salt
Résiste au sel
Salzbesändig
Стойкость к воздействию соли*

+ UNA GAMMA COMPLETA PER ARREDARE

*A complete design project
Une gamme complète pour décorer
Eine komplette einrichtungspalette
Полный ассортимент для оформления пространств*



PRODOTTI COORDINABILI INDOOR/OUTDOOR

*Because it can match indoor and outdoor
Produits compatibles indoor/outdoor
Kombinierbare indoor/outdoor-produkte
Сочетающиеся изделия для использования в помещениях и на улице*



Vedi catalogo tecnico completo.

*See complete technical catalog
Voir le catalogue technique complet.
Siehe vollständigen technischen Katalog.
См. полный технический каталог.*

	Proprietà fisico-chimiche / Physical chemical properties / Propriétés physico chimiques Физико химические Eigenschaften / Физико химические свойства	Metodo di prova Standard of test / Norme du test / Testnorm / Метод испытания	Àcanto	Charwood	Costruire*	Duomo	Evoca	Fossil
	Dimensioni Dimensions . Dimensions Abmessungen . Размеры	W 10 test ISO 10545 - 2						
	Aspetto superficiale Surface appearance . Aspect superficiel Oberflächenbeschaffenheit . Вид поверхности		≥ 95%	≥ 95%	≥ 95%	≥ 95%	≥ 95%	≥ 95%
	Lunghezza e larghezza Length and width Longueur et largeur Länge und Breite Длина и ширина		± 0,5% ± 1,5 mm	± 0,5% ± 2 mm	± 0,5% ± 1,5 mm	± 0,5% ± 2 mm	± 0,5% ± 1,5 mm	± 0,5% ± 1,5 mm
	Spessore Thickness . Épaisseur Stärke . Толщина		± 0,5% ± 1,5 mm	± 0,5% ± 2 mm	± 0,5% ± 1,5 mm	± 0,5% ± 2 mm	± 0,5% ± 1,5 mm	± 0,5% ± 1,5 mm
	Rettilineità degli spigoli Straightness of sides . Rectitude des arrêtes Kantengeradheit . Прямолинейность кромок		± 5% ± 0,5 mm	± 5% ± 0,5 mm	± 5% ± 0,5 mm	± 5% ± 0,5 mm	± 5% ± 0,5 mm	± 5% ± 0,5 mm
	Ortogonalità Rectangularity . Orthogonalité Rechtwinkligkeit . Ортогональность		± 0,5% ± 1,5 mm	± 0,5% ± 1,5 mm	± 0,5% ± 1,5 mm	± 0,5% ± 1,5 mm	± 0,5% ± 1,5 mm	± 0,5% ± 1,5 mm
Planarità Surface flatness . Planéité Ebenflächigkeit . Плоскостность	ISO 10545-2 ASTM C 485 Warpage diagonal/edge	± 0,5% ± 1,5 mm	± 0,5% ± 1,5 mm	± 0,5% ± 1,5 mm	± 0,5% ± 1,5 mm	± 0,5% ± 1,5 mm	± 0,5% ± 1,5 mm	
	Variazioni di tono Shade variations Variations de nuance Tonvariationen Вариация оттенка							
	Assorbimento d'acqua Water absorption Absorption d'eau Wasseraufnahme Водопоглощение	ISO 10545 - 3	E ≤ 0,1 % Bla GL	E ≤ 0,1 % Bla GL	E ≤ 0,1 % Bla UGL	E ≤ 0,1 % Bla GL	E ≤ 0,1 % Bla GL	E ≤ 0,1 % Bla GL
	Resistenza al gelo Frost resistant Résistance au gel Frostbeständigkeit Морозостойкость	ISO 10545 - 12	Resistente Resistant Résistant Widerstandsfähig Устойчивый	Resistente Resistant Résistant Widerstandsfähig Устойчивый	Resistente Resistant Résistant Widerstandsfähig Устойчивый	Resistente Resistant Résistant Widerstandsfähig Устойчивый	Resistente Resistant Résistant Widerstandsfähig Устойчивый	Resistente Resistant Résistant Widerstandsfähig Устойчивый
	Resistenza agli sbalzi termici Resistance to thermal shock Résistance aux écarts de température Temperaturwechselbeständigkeit Стойкость к тепловым перепадам	ISO 10545 - 9	Resistente Resistant Résistant Widerstandsfähig Устойчивый	Resistente Resistant Résistant Widerstandsfähig Устойчивый	Resistente Resistant Résistant Widerstandsfähig Устойчивый	Resistente Resistant Résistant Widerstandsfähig Устойчивый	Resistente Resistant Résistant Widerstandsfähig Устойчивый	Resistente Resistant Résistant Widerstandsfähig Устойчивый
	Resistenza della superficie (scala MOHS) Scratch hardness (MOHS scale) Dureté de la surface (échelle MOHS) Oberflächenhärte (MOHS skala) Поверхностная прочность по (шкале Мооса)	EN 101	MOHS ≥ 6	MOHS ≥ 6	MOHS ≥ 6	MOHS ≥ 6	MOHS ≥ 6	MOHS ≥ 6
	Resistenza alla abrasione della superficie di piastrelle smaltate Resistance to surface abrasion of glazed tiles Résistance à l'abrasion de la surface des carreaux émaillés Widerstand gegen Abrieb der Oberfläche der glasierten Fliesen Стойкость глазурованной плитки к поверхностному истиранию	ISO 10545 - 7	Grigio, Noce, Rovere: Classe 3 Class 3 Classe 3 Gruppe 3 Класс 3 Bianco, Miele: Classe 4 Class 4 Classe 4 Gruppe 4 Класс 4	Carbon, Burned: Classe 3 Class 3 Classe 3 Gruppe 3 Класс 3 Ash: Classe 4 Class 4 Classe 4 Gruppe 4 Класс 4	-	Noce: Classe 3 Class 3 Classe 3 Gruppe 3 Класс 3 Bianco, Crema, Grigio: Classe 4 Class 4 Classe 4 Gruppe 4 Класс 4	Grafite: Classe 3 Class 3 Classe 3 Gruppe 3 Класс 3 Ambra, Avorio, Cenere, Terra: Classe 4 Class 4 Classe 4 Gruppe 4 Класс 4	Bruno, Piombo: Classe 3 Class 3 Classe 3 Gruppe 3 Класс 3 Perla: Classe 4 Class 4 Classe 4 Gruppe 4 Класс 4 Crema, Perla Lux: Classe 5 Class 5 Classe 5 Gruppe 5 Класс 5
	Resistenza all'abrasione profonda Abrasion resistance Résistance à l'abrasion Verschleiß (Volumenverlust) Сопротивление глубокому истиранию	UNI EN ISO 10545-6	-	-	≤ 175 mm ³	-	-	-
	Resistenza ai prodotti chimici di uso domestico Resistance to household chemicals Résistance aux produits chimiques ménagers Widerstand gegen Haushaltsreiniger Стойкость к бытовым химикатам	ISO 10545 - 13 (no lux/lapp)	Classe A Class A Classe A Gruppe A Класс A	Classe A Class A Classe A Gruppe A Класс A	Classe A Class A Classe A Gruppe A Класс A	Classe A Class A Classe A Gruppe A Класс A	Classe A Class A Classe A Gruppe A Класс A	Classe A Class A Classe A Gruppe A Класс A
	Resistenza agli acidi e alle basi a bassa concentrazione Resistance to low concentrations of acids and bases Résistance aux acides et aux bases à faible concentration Widerstand gegen schwach konzentrierten Säuren und Laugen Стойкость к низкоконцентрированным кислотам и щелочам	ISO 10545 - 13 (no lux/lapp)	Classe LA - HA Class LA - HA Classe LA - HA Gruppe LA - HA Класс LA - HA	Classe LA - HA Class LA - HA Classe LA - HA Gruppe LA - HA Класс LA - HA	Classe LA - HA Class LA - HA Classe LA - HA Gruppe LA - HA Класс LA - HA	Classe LA - HA Class LA - HA Classe LA - HA Gruppe LA - HA Класс LA - HA	Classe LA - HA Class LA - HA Classe LA - HA Gruppe LA - HA Класс LA - HA	Classe LA - HA Class LA - HA Classe LA - HA Gruppe LA - HA Класс LA - HA
	Resistenza alle macchie di piastrelle smaltate Resistance to stains of glazed tiles Résistance aux taches des carreaux émaillés Widerstand gegen Fleckenbildner der glasierten Fliesen Стойкость глазурованной плитки к образованию пятен	ISO 10545 - 14	Classe 5 Class 5 Classe 5 Gruppe 5 Класс 5	Classe 5 Class 5 Classe 5 Gruppe 5 Класс 5	Classe 5 Class 5 Classe 5 Gruppe 5 Класс 5	Classe 5 Class 5 Classe 5 Gruppe 5 Класс 5	Classe 5 Class 5 Classe 5 Gruppe 5 Класс 5	Classe 5 Class 5 Classe 5 Gruppe 5 Класс 5
	Resistenza alla flessione Bending strength Résistance à la flexion Biegezugfestigkeit Прочность на изгиб	ISO 10545 - 4	Modulo di rottura - Modulus of rupture Module de rupture - Bruchmodul - Модуль жесткости R ≥ 35 N/mm ² Carico di rottura - Breaking of rupture Charge de rupture - Bruchkraft - нагрузка S ≥ 1300 N	R ≥ 35 N/mm ² S ≥ 1300 N	R ≥ 35 N/mm ² S ≥ 1300 N	R ≥ 35 N/mm ² S ≥ 1300 N	R ≥ 35 N/mm ² S ≥ 1300 N	R ≥ 35 N/mm ² S ≥ 1300 N
	Caratteristiche antiscivolo / Coefficiente d'attrito statico Anti-slip properties / Static coefficient of friction Caractéristiques antidérapantes / Coefficient de frottement statique Rutschhemmende Eigenschaft / Statischer Reibungskoeffizient Характеристики устойчивости к скольжению / Коэффициент статического трения	DIN 51130 (no lux/lapp)	R 10	R 10	R 10	R 10	R 10	R 10
		B.C.R.A. REP. CEC. 6/81 (no lux/lapp)	0,40 ≤ f ≤ 0,74	0,40 ≤ f ≤ 0,74	0,40 ≤ f ≤ 0,74	0,40 ≤ f ≤ 0,74	0,40 ≤ f ≤ 0,74	0,40 ≤ f ≤ 0,74
		DIN 51097 (no lux/lapp)	Classe B Class B Classe B Gruppe B Класс B	Classe A Class A Classe A Gruppe A Класс A	Classe B Class B Classe B Gruppe B Класс B	Classe B Class B Classe B Gruppe B Класс B	Classe C Class C Classe C Gruppe C Класс C	Classe B Class B Classe B Gruppe B Класс B
		DCOF Acu Test (no lux/lapp)	f ≥ 0,42	f ≥ 0,42	f ≥ 0,42	f ≥ 0,42	f ≥ 0,42	f ≥ 0,42
		Pendulum Australiano AS 4586	-	-	-	-	-	-
		Pendulum Britannico BS 7976	-	PTV > 36 wet	-	-	PTV > 36 wet	-
	Le classement UPEC du carrelage	-	-	-	-	30x60 . 12"x24" RETT → U4 P4 E3 C2 60x60 . 24"x24" RETT → U4 P4 E3 C2 80x80 . 32"x32" RETT → U4 P3 E3 C2 60x120 . 24"x48" RETT → U4 P3 E3 C2	-	

CARATTERISTICHE TECNICHE

TECHNICAL CHARACTERISTICS - CARACTÉRISTIQUES TECHNIQUES
TECHNISCHE DATEN - ТЕХНИЧЕСКИЕ ХАРАКТЕРИСТИКИ

GRES FINE PORCELLANATO SMALTATO. GLAZED FINE PORCELAIN STONEWARE. GRÈS CÉRAME FIN ÉMAILLÉ. GLASIERTES FEINSTEINZEUG. ТОНКОГО ГЛАЗУРОВАННОГО ФАРФОРОВОГО КЕРАМОГРАНИТА
* GRES PORCELLANATO A TUTTA MASSA. FULL BODY PORCELAIN STONEWARE. GRÈS CÉRAME PLAINE MASSE. VOLLMASSEFEINSTEINZEUG КЕРАМОГРАНИТ ПО ВСЕЙ ТОЛЩИНЕ

	Proprietà fisico-chimiche / Physical chemical properties / Propriétés physico chimiques Physisch chemische Eigenschaften / Физико химические свойства	Metodo di prova Standard of test / Norme du test / Testnorm / Метод испытания	Gemme	I Roveri	Magistra	Materica	Newport 2.0	Norway			
	Dimensioni Dimensions - Dimensions Abmessungen - Размеры										
	Aspetto superficiale Surface appearance - Aspect superficiel Oberflächenbeschaffenheit - Вид поверхности		≥ 95%	≥ 95%	≥ 95%	≥ 95%	≥ 95%	≥ 95%			
	Lunghezza e larghezza Length and width Longueur et largeur Länge und Breite Длина и ширина	W 10 test	± 0,5% ± 1,5 mm	± 0,5% ± 1,5 mm	± 0,5% ± 1,5 mm	± 0,5% ± 1,5 mm	± 0,5% ± 1,5 mm	± 0,5% ± 1,5 mm			
	Spessore Thickness - Épaisseur Stärke - Толщина		± 5% ± 0,5 mm	± 5% ± 0,5 mm	± 5% ± 0,5 mm	± 5% ± 0,5 mm	± 5% ± 0,5 mm	± 5% ± 0,5 mm			
	Rettilineità degli spigoli Straightness of sides - Rectitude des arrêtes Kantengeradheit - Прямолинейность кромок		± 0,5% ± 1,5 mm	± 0,5% ± 1,5 mm	± 0,5% ± 1,5 mm	± 0,5% ± 1,5 mm	± 0,5% ± 1,5 mm	± 0,5% ± 1,5 mm			
	Ortogonalità Rectangularity - Orthogonalité Rechtwinkligkeit - Ортогональность		± 0,5% ± 1,5 mm	± 0,5% ± 1,5 mm	± 0,5% ± 1,5 mm	± 0,5% ± 1,5 mm	± 0,5% ± 1,5 mm	± 0,5% ± 1,5 mm			
Planarità Surface flatness - Planéité Ebenflächigkeit - Плоскостность	ISO 10545-2 ASTM C 485 Warpage diagonal/edge	± 0,5% ± 1,5 mm ± 0,4%	± 0,5% ± 1,5 mm ± 0,4%	± 0,5% ± 1,5 mm ± 0,4%	± 0,5% ± 1,5 mm ± 0,4%	± 0,5% ± 1,5 mm ± 0,4%	± 0,5% ± 1,5 mm ± 0,4%	± 0,5% ± 1,5 mm ± 0,4%			
	Variazioni di tono Shade variations Variations de nuance Tonvariationen Вариация оттенка										
	Assorbimento d'acqua Water absorption Absorption d'eau Wasseraufnahme Водопоглощение	ISO 10545 - 3	E ≤ 0,1 % Bla GL	E ≤ 0,1 % Bla GL	E ≤ 0,1 % Bla GL	E ≤ 0,1 % Bla GL	E ≤ 0,1 % Bla GL	E ≤ 0,1 % Bla GL			
	Resistenza al gelo Frost resistant Résistance au gel Frostbeständigkeit Морозостойкость	ISO 10545 - 12	Resistente Resistant Résistant Widerstandsfähig Устойчивый	Resistente Resistant Résistant Widerstandsfähig Устойчивый	Resistente Resistant Résistant Widerstandsfähig Устойчивый	Resistente Resistant Résistant Widerstandsfähig Устойчивый	Resistente Resistant Résistant Widerstandsfähig Устойчивый	Resistente Resistant Résistant Widerstandsfähig Устойчивый			
	Resistenza agli sbalzi termici Resistance to thermal shock Résistance aux écarts de température Temperaturwechselbeständigkeit Стойкость к тепловым перепадам	ISO 10545 - 9	Resistente Resistant Résistant Widerstandsfähig Устойчивый	Resistente Resistant Résistant Widerstandsfähig Устойчивый	Resistente Resistant Résistant Widerstandsfähig Устойчивый	Resistente Resistant Résistant Widerstandsfähig Устойчивый	Resistente Resistant Résistant Widerstandsfähig Устойчивый	Resistente Resistant Résistant Widerstandsfähig Устойчивый			
	Resistenza della superficie (scala MOHS) Scratch hardness (MOHS scale) Dureté de la surface (échelle MOHS) Oberflächenhärte (MOHS skala) Поверхностная прочность по (шкале Мооса)	EN 101	MOHS ≥ 5	MOHS ≥ 6	MOHS ≥ 5	MOHS ≥ 6	MOHS ≥ 6	MOHS ≥ 6			
	Resistenza alla abrasione della superficie di piastrelle smaltate Resistance to surface abrasion of glazed tiles Résistance à l'abrasion de la surface des carreaux émaillés Widerstand gegen Abrieb der Oberfläche der glasierten Fliesen Стойкость глазурованной плитки к поверхностному истиранию	ISO 10545 - 7	Black Mirror: Classe 3 Class 3 Classe 3 Gruppe 3 Класс 3	Daino, Saturnia, Colorado, Breccia Sabbia: Classe 5 Class 5 Classe 5 Gruppe 5 Класс 5	Marquina: Classe 4 Class 4 Classe 4 Gruppe 4 Класс 4	Cappuccino: Classe 3 Class 3 Classe 3 Gruppe 3 Класс 3	Corinthian Fior di Bosco Paonazzetto: Classe 5 Class 5 Classe 5 Gruppe 5 Класс 5	New Ash: Classe 3 Class 3 Classe 3 Gruppe 3 Класс 3	New Birch, New Fir, New Maple: Classe 4 Class 4 Classe 4 Gruppe 4 Класс 4		
	Resistenza all'abrasione profonda Abrasion resistance Résistance à l'abrasion Verschleiß (Volumenverlust) Сопротивление глубокому истиранию	UNI EN ISO 10545-6	-	-	-	-	-	-			
	Resistenza ai prodotti chimici di uso domestico Resistance to household chemicals Résistance aux produits chimiques ménagers Widerstand gegen Haushaltsreiniger Стойкость к бытовым химикатам	ISO 10545 - 13	Classe A Class A Classe A Gruppe A Класс A	Classe A Class A Classe A Gruppe A Класс A	Classe A Class A Classe A Gruppe A Класс A	Classe A Class A Classe A Gruppe A Класс A	Classe A Class A Classe A Gruppe A Класс A	Classe A Class A Classe A Gruppe A Класс A			
	Resistenza agli acidi e alle basi a bassa concentrazione Resistance to low concentrations of acids and bases Résistance aux acides et aux bases à faible concentration Widerstand gegen schwach konzentrierten Säuren und Laugen Стойкость к низкоконцентрированным кислотам и щелочам	ISO 10545 - 13	Classe LA Class LA Classe LA Gruppe LA Класс LA	Classe LA - HA Class LA - HA Classe LA - HA Gruppe LA - HA Класс LA - HA	Classe LA Class LA Classe LA Gruppe LA Класс LA	Classe LA - HA Class LA - HA Classe LA - HA Gruppe LA - HA Класс LA - HA	Classe LA - HA Class LA - HA Classe LA - HA Gruppe LA - HA Класс LA - HA	Classe LA - HA Class LA - HA Classe LA - HA Gruppe LA - HA Класс LA - HA			
	Resistenza alle macchie di piastrelle smaltate Resistance to stains of glazed tiles Résistance aux taches des carreaux émaillés Widerstand gegen Fleckenbildner der glasierten Fliesen Стойкость глазурованной плитки к образованию пятен	ISO 10545 - 14	Classe 5 Class 5 Classe 5 Gruppe 5 Класс 5	Classe 5 Class 5 Classe 5 Gruppe 5 Класс 5	Classe 5 Class 5 Classe 5 Gruppe 5 Класс 5	Classe 5 Class 5 Classe 5 Gruppe 5 Класс 5	Classe 5 Class 5 Classe 5 Gruppe 5 Класс 5	Classe 5 Class 5 Classe 5 Gruppe 5 Класс 5			
	Resistenza alla flessione Bending strength Résistance à la flexion Biegezugfestigkeit Прочность на изгиб	ISO 10545 - 4	Modulo di rottura - Modulus of rupture Module de rupture - Bruchmodul - Модуль жесткости R ≥ 35 N/mm ² Carico di rottura - Breaking of rupture Charge de rupture - Bruchkraft - нагрузка S ≥ 1300 N	R ≥ 35 N/mm ² S ≥ 1300 N	R ≥ 35 N/mm ² S ≥ 1300 N	R ≥ 35 N/mm ² S ≥ 1300 N	R ≥ 35 N/mm ² S ≥ 1300 N	R ≥ 35 N/mm ² S ≥ 1300 N			
	Caratteristiche antiscivolo / Coefficiente d'attrito statico Anti-slip properties / Static coefficient of friction Caractéristiques antidérapantes / Coefficient de frottement statique Rutschhemmende Eigenschaft / Statischer Reibungskoeffizient Характеристики устойчивости к скольжению / Коэффициент статического трения	DIN 51130 (lux/lapp)	-	R 10	R 11	-	R 10	R 11	R 9	R 10	
		B.C.R.A. REP. CEC. 6/81 (no lux/lapp)	-	0,40 ≤ P ≤ 0,74		-	0,40 ≤ P ≤ 0,74		0,40 ≤ P ≤ 0,74		0,40 ≤ P ≤ 0,74
		DIN 51097 (no lux/lapp)	-	Classe B Class B Classe B Gruppe B Класс B	Classe C Class C Classe C Gruppe C Класс C	-	Classe B Class B Classe B Gruppe B Класс B	Classe C Class C Classe C Gruppe C Класс C	Classe B Class B Classe B Gruppe B Класс B	Classe C Class C Classe C Gruppe C Класс C	
		DCOF Acu Test (no lux/lapp)	-	P ≥ 0,42		-	P ≥ 0,42		P ≥ 0,42		P ≥ 0,42
		Pendulum Australiano AS 4586	-	-		-	-		-		-
		Pendulum Britannico BS 7976	-	-		-	-		-		-
	Le classement UPEC du carrelage	-	-	-	-	-	-	-	-		

	Proprietà fisico-chimiche / Physical chemical properties / Propriétés physico chimiques Physisch chemische Eigenschaften / Физико химические свойства	Metodo di prova Standard of test / Norme du test / Testnorm / Метод испытания	Promenade	Riabita il Cotto	Studio 50	Travertini Due	Showall	19 MM
	Dimensioni Dimensions . Dimensions Abmessungen . Размеры	W 10 test ISO 10545 - 2						
	Aspetto superficiale Surface appearance . Aspect superficiel Oberflächenbeschaffenheit . Вид поверхности		≥ 95%	≥ 95%	≥ 95%	≥ 95%	≥ 95%	≥ 95%
	Lunghezza e larghezza Length and width Longueur et largeur Länge und Breite Длина и ширина		± 0,5% ± 1,5 mm	± 0,5% ± 2 mm	± 0,5% ± 1,5 mm	± 0,5% ± 1,5 mm	± 0,5% ± 1,5 mm	± 0,5% ± 1,5 mm
	Spessore Thickness . Épaisseur Stärke . Толщина		± 0,5% ± 1,5 mm	± 0,5% ± 2 mm	± 0,5% ± 1,5 mm	± 0,5% ± 1,5 mm	± 0,5% ± 1,5 mm	± 0,5% ± 1,5 mm
	Rettilineità degli spigoli Straightness of sides . Rectitude des arrêtes Kantengeradheit . Прямолинейность кромок		± 5% ± 0,5 mm	± 5% ± 0,5 mm	± 5% ± 0,5 mm	± 5% ± 0,5 mm	± 5% ± 0,5 mm	± 5% ± 0,5 mm
	Ortogonalità Rectangularity . Orthogonalité Rechtwinkligkeit . Ортогональность		± 0,5% ± 1,5 mm	± 0,5% ± 1,5 mm	± 0,5% ± 1,5 mm	± 0,5% ± 1,5 mm	± 0,5% ± 1,5 mm	± 0,5% ± 1,5 mm
Planarità Surface flatness . Planéité Ebenflächigkeit . Плоскостность	ISO 10545-2 ASTM C 485 Warpage diagonal/edge	± 0,5% ± 1,5 mm	± 0,5% ± 1,5 mm	± 0,5% ± 1,5 mm	± 0,5% ± 1,5 mm	± 0,5% ± 1,5 mm	± 0,5% ± 1,5 mm	
	Variazioni di tono Shade variations Variations de nuance Tonvariationen Вариация оттенка							
	Assorbimento d'acqua Water absorption Absorption d'eau Wasseraufnahme Водопоглощение	ISO 10545 - 3	E ≤ 0,1 % Bla GL	E ≤ 0,1 % Bla GL	E ≤ 0,1 % Bla GL	E ≤ 0,1 % Bla GL	E ≤ 0,1 % Bla GL	E ≤ 0,1 % Bla GL
	Resistenza al gelo Frost resistant Résistance au gel Frostbeständigkeit Морозостойкость	ISO 10545 - 12	Resistente Resistant Résistant Widerstandsfähig Устойчивый	Resistente Resistant Résistant Widerstandsfähig Устойчивый	Resistente Resistant Résistant Widerstandsfähig Устойчивый	Resistente Resistant Résistant Widerstandsfähig Устойчивый	Resistente Resistant Résistant Widerstandsfähig Устойчивый	Resistente Resistant Résistant Widerstandsfähig Устойчивый
	Resistenza agli sbalzi termici Resistance to thermal shock Résistance aux écarts de température Temperaturwechselbeständigkeit Стойкость к тепловым перепадам	ISO 10545 - 9	Resistente Resistant Résistant Widerstandsfähig Устойчивый	Resistente Resistant Résistant Widerstandsfähig Устойчивый	Resistente Resistant Résistant Widerstandsfähig Устойчивый	Resistente Resistant Résistant Widerstandsfähig Устойчивый	Resistente Resistant Résistant Widerstandsfähig Устойчивый	Resistente Resistant Résistant Widerstandsfähig Устойчивый
	Resistenza della superficie (scala MOHS) Scratch hardness (MOHS scale) Dureté de la surface (échelle MOHS) Oberflächenhärte (MOHS skala) Поверхностная прочность по (шкале Мооса)	EN 101	MOHS ≥ 6	MOHS ≥ 6	MOHS ≥ 6	MOHS ≥ 6	MOHS ≥ 6	MOHS ≥ 6
	Resistenza alla abrasione della superficie di piastrelle smaltate Resistance to surface abrasion of glazed tiles Résistance à l'abrasion de la surface des carreaux émaillés Widerstand gegen Abrieb der Oberfläche der glasierten Fliesen Стойкость глазурованной плитки к поверхностному истиранию	ISO 10545 - 7	Ebano, Tan: Classe 3 Class 3 Classe 3 Gruppe 3 Класс 3 Argento, Corda, Sabbia: Classe 4 Class 4 Classe 4 Gruppe 4 Класс 4	Classe 4 Class 4 Classe 4 Gruppe 4 Класс 4	Studio Corvino: Classe 3 Class 3 Classe 3 Gruppe 3 Класс 3 Studio Terracotta, Studio Peltro, Studio Verderame, Studio Perla, Studio Sabbia: Classe 4 Class 4 Classe 4 Gruppe 4 Класс 4	Beige: Classe 4 Class 4 Classe 4 Gruppe 4 Класс 4 Bianco, Greige: Classe 5 Class 5 Classe 5 Gruppe 5 Класс 5		Classe 3 - 4 Class 3 - 4 Classe 3 - 4 Gruppe 3 - 4 Класс 3 - 4
	Resistenza all'abrasione profonda Abrasion resistance Résistance à l'abrasion Verschleiß (Volumenverlust) Сопротивление глубокому истиранию	UNI EN ISO 10545-6	-	-	-	-	-	-
	Resistenza ai prodotti chimici di uso domestico Resistance to household chemicals Résistance aux produits chimiques ménagers Widerstand gegen Haushaltsreineriger Стойкость к бытовым химикатам	ISO 10545 - 13 (no lux/lapp)	Classe A Class A Classe A Gruppe A Класс A	Classe A Class A Classe A Gruppe A Класс A	Classe A Class A Classe A Gruppe A Класс A	Classe A Class A Classe A Gruppe A Класс A		Classe A Class A Classe A Gruppe A Класс A
	Resistenza agli acidi e alle basi a bassa concentrazione Resistance to low concentrations of acids and bases Résistance aux acides et aux bases à faible concentration Widerstand gegen schwach konzentrierten Säuren und Laugen Стойкость к низкоконцентрированным кислотам и щелочам	ISO 10545 - 13 (no lux/lapp)	Classe LA - HA Class LA - HA Classe LA - HA Gruppe LA - HA Класс LA - HA	Classe LA - HA Class LA - HA Classe LA - HA Gruppe LA - HA Класс LA - HA	Classe LA - HA Class LA - HA Classe LA - HA Gruppe LA - HA Класс LA - HA	Classe LA - HA Class LA - HA Classe LA - HA Gruppe LA - HA Класс LA - HA		Classe LA - HA Class LA - HA Classe LA - HA Gruppe LA - HA Класс LA - HA
	Resistenza alle macchie di piastrelle smaltate Resistance to stains of glazed tiles Résistance aux taches des carreaux émaillés Widerstand gegen Fleckenbildner der glasierten Fliesen Стойкость глазурованной плитки к образованию пятен	ISO 10545 - 14	Classe 5 Class 5 Classe 5 Gruppe 5 Класс 5	Classe 5 Class 5 Classe 5 Gruppe 5 Класс 5	Classe 5 Class 5 Classe 5 Gruppe 5 Класс 5	Classe 5 Class 5 Classe 5 Gruppe 5 Класс 5		Classe 5 Class 5 Classe 5 Gruppe 5 Класс 5
	Resistenza alla flessione Bending strength Résistance à la flexion Biegezugfestigkeit Прочность на изгиб	ISO 10545 - 4	Modulo di rottura - Modulus of rupture Module de rupture - Bruchmodul - Модуль жесткости R ≥ 35 N/mm ² Carico di rottura - Breaking of rupture Charge de rupture - Bruchkraft - нагрузка S ≥ 1300 N	R ≥ 35 N/mm ² S ≥ 1300 N	R ≥ 35 N/mm ² S ≥ 1300 N	R ≥ 35 N/mm ² S ≥ 1300 N		R ≥ 50 N/mm ² S ≥ 5000 N
	Caratteristiche antiscivolo / Coefficiente d'attrito statico Anti-slip properties / Static coefficient of friction Caractéristiques antidérapantes / Coefficient de frottement statique Rutschhemmende Eigenschaft / Statischer Reibungskoeffizient Характеристики устойчивости к скольжению / Коэффициент статического трения	DIN 51130 (lux/lapp)	R 10	R 11	R 10	R 10	R 11	R 11
		B.C.R.A. REP. CEC. 6/81 (no lux/lapp)	0,40 ≤ f ≤ 0,74	0,40 ≤ f ≤ 0,74	0,40 ≤ f ≤ 0,74	0,40 ≤ f ≤ 0,74	0,40 ≤ f ≤ 0,74	0,40 ≤ f ≤ 0,74
		DIN 51097 (no lux/lapp)	Classe B Class B Classe B Gruppe B Класс B	Classe C Class C Classe C Gruppe C Класс C	Classe B Class B Classe B Gruppe B Класс B	Classe C Class C Classe C Gruppe C Класс C	Classe B Class B Classe B Gruppe B Класс B	Classe C Class C Classe C Gruppe C Класс C
		DCOF Acu Test (no lux/lapp)	f ≥ 0,42	f ≥ 0,42	f ≥ 0,42	f ≥ 0,42	f ≥ 0,42	f ≥ 0,42
		Pendulum Australiano AS 4586	-	-	-	-	-	-
		Pendulum Britannico BS 7976	-	-	-	-	-	-
	Le classement UPEC du carrelage		30x60 . 12"x24" RETT → U4 P4 E3 C2 60x60 . 24"x24" RETT → U4 P4 E3 C2 60x120 . 24"x48" RETT → U4 P3 E3 C2	-	30x60 . 12"x24" RETT → U4 P4 E3 C2 60x60 . 24"x24" RETT → U4 P4 E3 C2 80x80 . 32"x32" RETT → U4 P3 E3 C2 60x120 . 24"x48" RETT → U4 P3 E3 C2	-	-	-

Serenissima, nell'intento di fornire prodotti adeguati ad ogni tipo di ambiente, produce una vasta gamma di superfici in grado di rispondere ad ogni condizione e necessità d'impiego. Oltre alle superfici classiche, vengono prodotti pavimenti antiscivolo sia con la tecnica delle applicazioni superficiali di smalti adeguati, che tramite l'utilizzo di idonei stampi strutturati. Inoltre per ottemperare alla richiesta in tema estetico si forniscono prodotti lappati o con superfici che per loro natura creano disegni o forme esteticamente apprezzabili.

Serenissima is producing porcelain tiles with a wide range of surfaces studied on purpose for every use and condition, in order to be suitable for any kind of project. Beside standard surfaces, Serenissima is producing antislip surfaces using superficial and appropriate applications or using directly structure molds during production. In order to achieve high aesthetic requirements Serenissima offering also honed and special finishes that makes porcelain tiles extremely appealing and in line with current trends.

L'usine Serenissima, afin de fournir des produits appropriés à tous les niveaux d'application, réalise une grosse gamme de surfaces différentes capable de satisfaire toutes les nécessités d'emploi. En plus des surfaces classiques, nous réalisons des finitions anti-slip (ou antidérapantes) aussi bien avec l'application de traitements de produits appropriés qu'avec l'utilisation de moules structurés. Encore, afin d'enrichir le niveau esthétique de la gamme des produits et les choix disponibles, nous fournissons aussi des finitions polis et semi polis (ou adoucis).

Da sehr unterschiedliche Einsatzbereiche gibt, produzierten Serenissima mehrere Oberflächen. Es werden klassische Oberflächen und rutschfeste Oberflächen produziert, entweder mit rutschfesten Glasuren oder mit strukturierten Stempeln. Fuer aestetisch hoehe Ansprueche werden polierte oder angeschliffene Oberflächen angefertigt.

Стремясь поставить материал, подходящий для отделки любого типа помещений, Serenissima предлагают широкий ассортимент поверхностей плитки, способный удовлетворить самые разные условия и требования к использованию. Serenissima производят и классические поверхности, и противоскользящие полы, используя при этом, как технику нанесения специальных поверхностных эмалей, так и структурированные пресс-формы. Кроме того, для удовлетворения эстетических требований, изготавливается полированная и/или шлифованная продукция, а так же изделия с поверхностями, которые за счёт своих свойств образуют рисунки или формы с ценными эстетическими качествами.

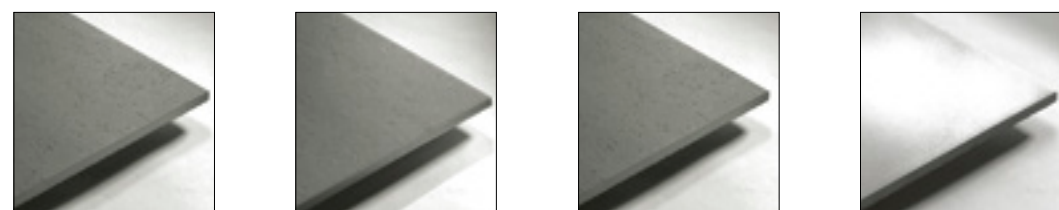

SUPERFICIE NATURALE

SUPERFICIE NATURALE/RETTIFICATA R11

SUPERFICIE NATURALE RETTIFICATA

SUPERFICIE RETTIFICATA LUX/LAPPATA

VARIAZIONI DI TONO

SHADE VARIATIONS . VARIATIONS DE NUANCE
TONVARIATIONEN . СТЕПЕНЬ РАЗНОТОННОСТИ



V1
ASPETTO UNIFORME
UNIFORM APPEARANCE
ASPECT UNIFORME
EINHETLICHES AUSSEHEN
УМЕРЕННОЕ ИЗМЕНЕНИЕ

V2
LIEVE VARIAZIONE
SLIGHT VARIATION
LEGERE VARIATION
GERINGE ABWEICHUNG
ЛЕГКОЕ ИЗМЕНЕНИЕ

V3
MODERATA VARIAZIONE
MODERATE VARIATION
VARIATION MODEREE
MÄSSIGE ABWEICHUNG
УМЕРЕННОЕ ИЗМЕНЕНИЕ

V4
FORTE STONALIZZAZIONE
SUBSTANTIAL VARIATION
EFFET DENUANCE TRES ACCENTUE
AKZENTUIERTE VARIATION
БОЛЬШАЯ РАЗНИЦА ТОНА

SCIVOLOSITA'

La resistenza allo scivolamento è una caratteristica che ricade su sicurezza e salute degli utilizzatori, oviamente nel caso di pavimentazioni. Le superfici scivolose sono potenziali cause di infortuni, anche gravi sia in ambito civile che negli ambienti di lavoro. La grandezza che quantifica la resistenza allo scivolamento è il coefficiente di attrito (statico o dinamico), al quale è proporzionale la forza, parallela alla superficie di contatto, che occorre applicare perchè si abbia moto relativo tra due corpi, e quindi anche la forza che ne definisce le condizioni di equilibrio. Quanto più alto è il coefficiente di attrito, tanto minore è la scivolosità. Attualmente non è disponibile un metodo di misura standardizzato a livello internazionale, la maggior parte delle nazioni ha metodi propri derivati da leggi, disposizioni antinfortunistiche o altre regolamentazioni di carattere nazionale. Per aver un buon risultato, il valore medio del coefficiente di attrito dinamico deve essere: $\mu > 0,40$, $R \geq R9$ e $\mu \geq A$. Qui di seguito riportiamo la sintesi degli indicatori che misurano la resistenza alla scivolosità:

R: indica l'angolo di inclinazione raggiunto nel test di prova

A.B.C.: sono riferimenti di resistenza alla scivolosità relativa ad ambienti umidi e a piedi nudi.

SLIP RESISTANCE Slip resistance is a characteristic that affects the health and safety of users in the case of flooring. Slippery surfaces are potential causes of accidents, even serious ones, in civil and work environments. The value that measures slip resistance is the coefficient of friction (static or dynamic); the force required for the relative movement between two bodies (and therefore also the force defining the equilibrium condition), the said force being parallel to the contact surface, is proportional to the coefficient of friction. The higher the coefficient of friction, the less slippery is the surface. An international standardised measurement is not currently available and most countries have their own measurement methods based on laws, accident prevention regulations or other national regulations. For a good result, the average dynamic coefficient of friction should be: $\mu > 0.40$, $R \geq R9$ and $\mu \geq A$. Here below a short description of the indicators to measure slip-resistance:

R: angle of slope achieved during testing

A.B.C.: slip resistance indicators for walking in humid areas.

GLISSANCE La résistance à la glissance du carrelage est une caractéristique très importante pour la sécurité et la santé des utilisateurs et des professionnels pendant la pose du matériel. Les surfaces glissantes sont potentiellement cause d'accidents, même graves, dans le niveau civil comme professionnel. La grandeur qui quantifie la résistance au glissement est le coefficient de frottement (statique ou dynamique), qui est proportionnelle à la force, parallèle à la surface de contact, qui devrait être appliquée, car il ya du mouvement relatif entre les deux organes, et donc aussi la force qui définit les conditions d'équilibre. Plus le coefficient de frottement est grand, moins importante sera la glissance. Actuellement, il n'existe aucune méthode normalisée de mesure de niveau international, la plupart des nations ont leurs propres méthodes dérivées de lois, règles ou règlements de prévention de caractère national. Pour un bon résultat, la valeur moyenne du coefficient de frottement dynamique, devrait être: $\mu > 0,40$, $R \geq R9$ e $\mu \geq A$. Voici un résumé des indicateurs qui mesurent la résistance à la glisse:

R: indique l'angle d'inclinaison mesurée avec le test.

A.B.C.: sont des valeurs de resistance à la glisse relatives aux niveaux humides et à pieds nus.

RUTSCHIGKEIT Natürlich ist die Rutschfestigkeit eine Eigenschaft, die sich im Bereich der Bodenbeläge auf die Sicherheit und Gesundheit der Anwender auswirkt. Rutschige Oberflächen sind mögliche Ursachen für unter Umständen auch schwere Unfälle sowohl im zivilen Bereich als in der Arbeitsumgebung. Die Größe, die die Rutschfestigkeit misst, ist der Reibungskoeffizient (statisch und dynamisch). Zu diesen verhält sich die Kraft proportional, die parallel zur Kontaktfläche wirkt und angewandt werden muss, damit eine relative Bewegung zwischen zwei Körpern erfolgt. Somit ist sie auch die Kraft, die die Bedingungen für das Gleichgewicht bestimmt. Je höher der Reibungskoeffizient ist, umso niedriger ist die Rutschigkeit. Derzeit steht auf internationaler Ebene keine standardisierte Messmethode zur Verfügung. Der Großteil der Länder besitzt eigene Methoden, die auf Gesetzen, Unfallschutzbestimmungen oder anderen Regelungen nationaler Art beruhen. Um ein gutes Ergebnis zu erzielen, muss der durchschnittliche Wert des dynamischen Reibungskoeffizienten betragen: $\mu > 0,40$, $R \geq R9$ und $\mu \geq A$.

Nachfolgend führen wir eine Zusammenfassung der Indikatoren auf, mit denen die Rutschfestigkeit gemessen wird:

R: gibt den beim Test erreichten Neigungswinkel an

A.B.C.: sind Bezüge der Rutschfestigkeit hinsichtlich Feuchträume und Füße

СОПРОТИВЛЕНИЕ СКОЛЬЖЕНИЮ Устойчивость к скольжению - это характеристика, от которой зависит безопасность и здоровье потребителей, конечно, в случае, если речь идет а напольных покрытиях. Скользяие поверхности являются потенциальной причиной несчастных случаев, иногда также тяжелых, как в жилых, так и в промышленных помещениях. Величиной, определяющей устойчивость к скольжению, является коэффициент трения (статического или динамического), которому пропорциональна сила, параллельная контактной поверхности, которую необходимо приложить для получения относительного движения между двумя телами, и, следовательно, также сила, которая определяет условия их равновесия. Чем больше коэффициент трения, тем меньше способность к скольжению. В настоящее время не существует международного стандартного метода измерения этой величины, большинство государств использует свои собственные методы, исходя из положений законов, норм техники безопасности или других национальных нормативов. Для получения хорошего результата среднее значение коэффициента динамического скольжения должна составлять $\mu > 0,40$, $R \geq R9$ und $\mu \geq A$.

Ниже перечислены показатели, измеряющие устойчивость к скольжению:

R: означает уклон, полученный при тестировании во время испытаний

A.B.C.: показатели устойчивости к скольжению во влажных помещениях и при движении босыми ногами.

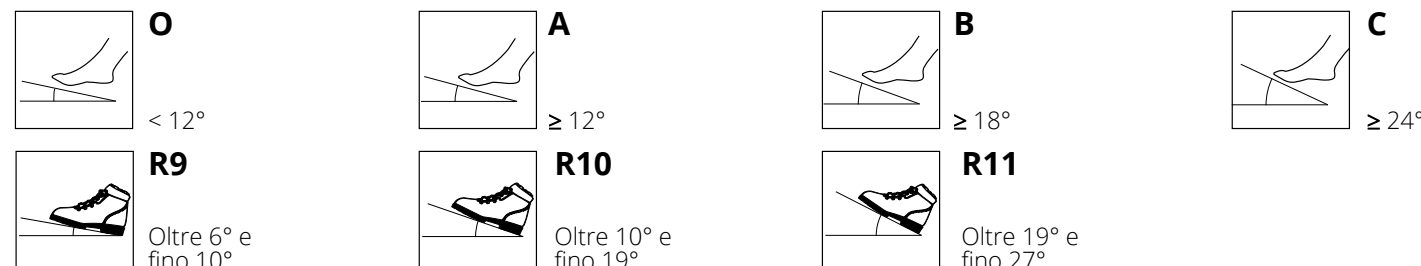

POSE ET LAVAGE

Carrelage dans une cuisine

Carrelage dans une chambre

CONSEILS POUR LA POSE

La réalisation optimale d'un carrelage en grès cérame de Serenissima est due non seulement aux qualités techniques et esthétiques du matériel, mais aussi à un ensemble d'éléments (fond, couche de liant, joints de dilatation, ect.) constituant un véritable système. Les opérations de pose, exécutées dans la suite exacte, doivent etre considérées importantes comme le choix des carreaux. Pour le choix du produit collant plus convenable et pour les modalités d'application, il est conseillé de se conformer aux instructions fournies par la maison de fabrication du produit collant. Le projet de chaque surface carrelée doit être confié à un expert qui, selon la structure, la fonction, les charges prévues et les contraintes mécaniques, thermiques, physiques et chimiques auxquelles le carrelage sera soumis, établira les consignes en matière d'épaisseur des couches de forme, its de ciment, dés, carreaux, inclinaison et pour tout le système de pose. En outre, l'architecte doit reprendre tous les détails du chantier dans le cahier de charges, notamment le type et le mode de pose, les matériaux, la granulométrie, les dosages, les dimensions des écarts, des joints de structure, les joints de dilatation, les joints périmétraux, ect.

MODALITES DE POSE

1. Choisir avec soin les carreaux en fonction des exigences esthétiques et techniques du lieu de pose, le format, le schéma de pose, les dimensions et la couleur des joints.
2. Une pose sans écarts est fortement conseillée même si elle n'est pas recommandées en extérieur. En cas de pose modulaire de plusieurs formats, prévoir des joints de - 2 mm pour les articles rectifiés; - 4 ou 5 mm pour les articles NON rectifiés.
3. A signaler à la commande: toujours indiquer si le matériau désiré est destiné à une pose multiformat afin de permettre aux commerciaux d'envoyer aux clients les calibres et les tons assortis.
4. Les grès Serenissima peuvent être posés à l'aide de ciment traditionnel ou de colle.
5. Procéder à la pose dans les règles de l'art en suivant les indications de l'architecte, du responsable de chantier et du cahier de charges.
6. Pour une meilleure gestion du chantier, il est essentiel de respecter les temps de mise en place des matériaux utilisés en suivant les indications fournies par les fabricant.
7. Controler les matériaux avant la mise en oeuvre. Des réclamations concernant le matériel déjà mis en oeuvre, ne seront pas acceptées.
8. Appuyer sur le sol quelques pieds (au moins 3 mc) pour apprécier l'effet global. Poser le matériel en le prenant de plusieurs boîtes et en contrôlant l'épaisseur, les nuances et la qualité des différentes pièces.
9. La haute degré de greification des carreaux de Serenissima comporte une modeste différence de calibre; c'est pourquoi nous conseillons lors de la pose de laisser au moins un joint de 3 mm entre les carreaux.
10. Ne pas marquer la partie supérieure par des crayons ou des feutres.
11. Attendre 48/72 heures avant de transiter sur le carrelage. Les variations chromatiques du produit sont donc un trait distinctif que seul l'habilité du poseur peut valoriser pour créer un carrelage unique et incomparable. Un beau carreau mal posé ne donne pas un bon résultat esthétique.
12. Pose conseillée avec un décalage entre chaque listel non supérieur au 25% de la longueur.

CONSEILS POUR LA POSE DES MATERIAUX RECTIFIES
La pose du produit rectifié sans joint demande une très grande attention et précision de la part de l'installateur pour ce qui est de la planéité du plan de pose et pour la continuité des joints. Pour réaliser une pose parfaite, Serenissima suggère de maintenir au moins 2 mm de joint pour la pose des monoformats, et pour les combinaisons de formats mixtes aussi.

La pose sans joint, surtout pour ce qui concerne les grands formats, est fortement déconseillée par la plupart des producteurs de colle, pour les motifs suivants:

- difficulté pour absorber les éventuels mouvements du carrelage;
- dilatation différente entre le carrelage et la chape, en présence de grandes variations de température;
- difficulté pour réaliser un joint efficace et durable.

Serenissima déconseille totalement des poses sans joint. Dès lors, la société ne saurait être tenue pour responsable des conséquences de ce choix. Serenissima conseille de faire des joints de 2 mm minimum pour poser le produit rectifié.

CONSEILS POUR LA POSE DES MATERIAUX RECTIFIES

La pose du produit rectifié sans joint demande une très grande attention et précision de la part de l'installateur pour ce qui est de la planéité du plan de pose et pour la continuité des joints. Pour réaliser une pose parfaite, Serenissima suggère de maintenir au moins 2 mm de joint pour la pose des monoformats, et pour les combinaisons de formats mixtes aussi.

La pose sans joint, surtout pour ce qui concerne les grands formats, est fortement déconseillée par la plupart des producteurs de colle, pour les motifs suivants:

- difficulté pour absorber les éventuels mouvements du carrelage;
- dilatation différente entre le carrelage et la chape, en présence de grandes variations de température;
- difficulté pour réaliser un joint efficace et durable.

Serenissima déconseille totalement des poses sans joint. Dès lors, la société ne saurait être tenue pour responsable des conséquences de ce choix. Serenissima conseille de faire des joints de 2 mm minimum pour poser le produit rectifié.

CONSEILS POUR LA POSE DES MATERIAUX RECTIFIES

Chers clients Serenissima, nous vous demandons d'informer; avant la livraison; les poseurs et/ou les destinataires de nos produits, des conseils, avertissements et recommandations présents dans ce catalogue. Serenissima décline toute responsabilité due à l'absence de telles informations, qui peuvent causer des problèmes au produit durant ou après la pose.

Carrelage dans une chambre

Carrelage dans une cuisine

MASTICAGE

1. Si l'on utilise du coulis constitué de ciment et sable, nous conseillons d'utiliser du mastic dans des couleurs ton sur ton (si possible, pour les matériels clairs ne pas utiliser de mastics d'une couleur sombre, telle que noir, bleu, rouge).
2. Mastiquer des petites surfaces (4 à 5 mc) et éliminer les excès à l'aide d'éponges, des chiffons imbibés d'eau propre ou des machines spécialement conçues pour éliminer le mastic en excès.
3. Comblér les écarts à l'aide de mastic uniquement lorsque le carrelages est praticable. Veiller à retirer les résidus éventuels des écarts avant de procéder.
4. Procéder au masticage dans les règles de l'art en suivant les indications de l'architecte, du responsable de chantier et du cahier de charges.
5. Enduits de ciment non dopés: à la fin de la journée, nettoyer les résidus de pose à l'aide d'une éponge légèrement humide. Sauf indication contraire du fabricant, le nettoyage du carrelage doit être effectué après 4-5 jours (afin de permettre au mastic de sécher). Il faudra d'abord humidifier les joints avec de l'eau pour ensuite recourir à des détergents à base acide spécialement prévus pour ce type d'utilisation. Ne pas attendre trop longtemps avant de procéder au nettoyage car au bout de deux semaines, il est déjà beaucoup plus d'obtenir des résultats satisfaisants. Ne pas nettoyer après la pose si la température des dalles est élevée. En été, nettoyer au cours de la période la plus fraîche de la journée.
6. Mastics époxy ou dopés (avec latex, etc.): suivre attentivement les indications des fabricants car le durcissement des mastics peut rendre le nettoyage difficile, surtout en présence de carreaux antidérapantes, rugueuses ou structurées.

LAVAGE, PROTECTION ET ENTRETIEN DU GRÈS CÉRAMÉ
Le soin dans le nettoyage de votre carrelage après la pose influencera la facilité et l'entretien de celui-ci pour toute sa durée de vie.

NETTOYAGE APRÈS LA POSE
L'importance du nettoyage après la pose est fondamentale pour garantir la qualité de l'entretien et la maintenance future de votre carrelage.

Avec un lavage acide après la pose il est possible d'éliminer le résidu de toutes les substances que l'on retrouve habituellement sur un chantier: colle, peinture, ciment, etc.... Nous vous rappelons que 90% et plus des litiges sur les chantiers sont dus à de mauvaises applications de produits de nettoyage à base d'acides, ou encore à la complète absence de traitements après la pose.

Pour éviter que le lavage après la pose à base acide puisse détériorer le ciment des joints, il est nécessaire de mouiller la surface pour permettre l'absorption d'eau et donc la protection contre l'action érosive sur les joints.

Si le premier nettoyage après la pose doit être fait après une première utilisation de votre sol sur le chantier, il sera opportun d'éliminer avec des détergents alcalins toutes les traces de graisses ou similaires avant d'appliquer le nettoyage après la pose à base acide. Suite au lavage il faut bien rincer le sol avec de l'eau claire. L'eau doit être récupérée rapidement sur la surface avant qu'elle ne sèche. Le lavage après la pose doit être fait après le complet séchage et stabilisation des joints à base de ciment (au moins 36-48 heures), dans le respect scrupuleux des instructions du mode d'emploi données par le fabricant du détergent.

Le lavage après la pose avec des produits à base acide, appliqués à l'éponge, doit être fait en une seule fois et donne l'avantage d'obtenir aussi une uniformité chromatique du sol.

ENTRETIEN QUOTIDIEN
Il est recommandé d'utiliser un produit détergent ordinaire, neutre et dilué dans de l'eau. Eviter toute utilisation d'acides, alcalins, produits de cirage et/ou imprégnants. Lors du nettoyage au quotidien il faut limiter au maximum l'emploi de systèmes fortement abrasifs (comme par exemple, les paillettes métalliques; ou les éponges de fer). Cette précaution devient obligatoire lorsque les carreaux ont une surface brillante , ils sont donc plus exposés aux effets visibles des rayures, des griffes , de l'opacification. En cas de saleté plus consistante ou de surfaces particulièrement structurées, il est conseillé d'utiliser un produit détergent à base alcaline en prenant soin de bien rincer en fin de lavage. Pour les grandes surfaces, il est recommandé d'utiliser des machines lavantes et séchantes. Dans l'utilisation au quotidien, il faut tenir

compte que certaines saletés (poussière, sable) augmentent l'effet abrasif avec le trafic piétonnier. Essayer par conséquent d'anticiper la présence de ce type de saleté, qui provient de l'extérieur, en recourant à l'emploi de tapis brosse à l'entrée.

ENTRETIEN EXTRAORDINAIRE

En cas de saleté résistant au nettoyage ordinaire, il est recommandé d'utiliser un produit détergent adapté au type de saleté plus persistantes.

SOLS ET REVÊTEMENTS MÉTALLISÉS

Pour le nettoyage et l'entretien des carreaux métallisés il est conseillé de ne pas utiliser des détergents acides ou alcalins. Il faut utiliser exclusivement des produits avec PH neutre. De plus, il faut toujours effectuer un essai sur une portion de matériel non posé et éviter de laisser le détergent sur le carrelage pour plus de 10-15 minutes. Enfin, il faut toujours rincer abondamment avec de l'eau claire.

RECOMMANDATIONS

Pour finir, il faut se souvenir de ne jamais utiliser des détergents à base d'acide fluorhydrique (HF) ou de ses composés, y compris antirouille ou détachant.

Le dommage qui pourrait être provoqué suite à l'utilisation de cet acide sera irréparable, étant donné qu'il n'existe pas de carrelage sur le marché résistant à un tel acide.

MISE EN GARDE

Les caractéristiques de nettoyage des matériaux peuvent variées de façon significative selon les modalités de pose, les conditions d'utilisation, les types de surfaces et de lieux. Généralement, plus les caractéristiques antidérapantes des carreaux sont élevées, plus le nettoyage est difficile.

Avant chaque intervention, l'opérateur professionnel chargé de l'entretien et du nettoyage devra toujours effectuer un contrôle empirique (si possible sur une portion de matériau non posé). Serenissima décline toute responsabilité quant à l'efficacité des opérations de nettoyage et d'entretien en cas de pose ou de nettoyages non adaptés, ainsi que dans des conditions d'utilisation particulièrement difficiles (par exemple, ateliers de mécaniciens ou dans des endroits avec des résidus huileux importants et des traces de pneus), ainsi qu'en cas de choix erroné pour ce qui concerne la typologie des matériaux installés et des colles utilisées. Tous les renseignements présents dans ce document sont donnés a titre indicatifs.

Pour des renseignements plus techniques nous vous recommandons des documentations spécifiques comme les modes d'emploi déjà présentés sur les étiquettes emballages des produits, ou directement chez les fabricants de détergents pour le nettoyage de sol, ou encore sur les sites web des principales sociétés productrices de produits spécifiques pour le nettoyage des sols comme par exemple : Fila Industria Chimica spa (www.filachim.com), Mapei S.p.a. (www.mapei.it), Kerakoll S.p.A. (www.kerakollgroup.com), Bonasystems Italia S.r.l. (www.bonasystemstalia.it), Faber Chimica S.r.l. (www.faberchimica.com), Periscopio s.r.l. (www.periscopiosoluzioni.com).

TRAITEMENT DES PRODUITS POLIS ET LEVIGES

Le polissage et la levigation sont des opérations qui prévoient l'enlèvement et l'astiquage de la partie superficielle de l'email, ou du corps même du carrelage. Dans tous les sols en céramique disponibles sur le marché, une telle opération ; même en présence de matériaux vitreux ou de très basse absorption; peut comporter l'ouverture de microporosité superficielle qui, au contact avec des particules comme la saleté, peuvent résulter de nettoyage difficile ou présenter des auréoles qui s'enlèveront difficilement.

Serenissima conseille, après le lavage après pose qui doit-être effectué en utilisant un détergent à base acide, d'éviter une protection anti-tâches avec des produits certifiés, afin d'éviter que le matériel puisse absorber les tâches en maintenant inchangées les caractéristiques esthétiques et techniques du grès emailé.

Nous vous rappelons que quel que soit le traitement effectué par le producteur après pose, celui-ci sera totalement enlevé par le lavage à base acide qui devra être effectué successivement à la pose et donc, aucun produit anti-tâches ne pourra être garanti.

VERLEGUNG UND REINIGUNG

Verlegung des Fliesenbelages

Verlegung des Fliesenbelages

VERLEGEHINWEISE

Die einwandfreie Verlegung eines Bodens mit Feinstezeug von Serenissima ist nicht nur auf die technischen und ästhetischen Eigenschaften des Produkts, sondern auch auf die gesamten Elemente (Untergrund, Bindschicht, Dehnfugen, usw.) zurückzuführen. Auch die in korrekter Reihenfolge durchgeführten Verlegevorgänge sind als so wichtig wie die Auswahl der Fliesen zu betrachten. Für die Auswahl des am besten dazupassenden Klebers und für die technische Anweisungen wird empfohlen, die Hinweise des Kleberherstellers zu beachten. Die Planung einer jeden gefliesten Oberfläche sollte in die Hände eines Planungsfachmannes gegeben werden, der unter Berücksichtigung von Struktur, Verwendungszweck der Räume, vorgesehner Belastung, mechanischer, thermischer, physikalischer und chemischer Beanspruchung des Fußbodens, den Untergrund, die Zementschichten, die Auftragung, die Keramikfliesen, das Gefälle und das gesamte Verlegungssystem berechnet. Darüber hinaus ist es die Aufgabe des Planungsfachmannes, im Leistungsverzeichnis jede Besonderheit der Baustelle, z.B. Art des Verlegens und Vorgehensweise beim Verlegen, Materialien, Korngrößenanalyse, Dosierungen, Fugen Größen, Struktur- und Dehnungsfugen, Perimeterdämmung etc. festzuhalten.

DAS VERLEGEN

1. Werden Sie sich klar über die ästhetischen und technischen Anforderungen, die an die Fliesen gestellt werden (im Verhältnis zum Stil und zum Verwendungszweck der Räume), und wählen Sie die zu verlegenden Größen, das Verlegungsmuster, die Breite und die Farbe der Fugen sorgfältig aus.
2. Vom Verlegen ohne Fugen wird völlig abgeraten und ist in Außenbereichen sogar grundsätzlich nicht möglich. Sollten Sie Fliesen verschiedener Größen modular verlegen wollen, sind folgende Fugenbreiten vorzusehen: - 2 mm für kalibrierte Fliesen; - 4 oder 5 mm für NICHT kalibrierte Fliesen.
3. Angaben bei Auftragserteilung: Bitte immer genau angeben, ob der gewünschte Bodenbelag im Multiformat verlegt werden soll (hierbei werden in einem Raum/ auf einer Fläche Fliesen unterschiedlicher Größe verlegt), um es den Fachhändlern zu ermöglichen, den Kunden die Fliesen in Maß und Farbton aufeinander abgestimmt zu liefern.
4. Das Feinstezeug Serenissima kann sowohl mit herkömmlichem Mörtel als auch mit Fliesenkleber verlegt werden.
5. Verlegen Sie die Fliesen sachgerecht und befolgen Sie dabei die Anweisungen des Planungsfachmanns, des Poliers und des Leistungsverzeichnisses.
6. Um einen reibungslosen Ablauf auf der Baustelle zu gewährleisten, ist es von besonderer Bedeutung, die verwendeten Materialien im richtigen zeitlichen Abstand und gemäß der Anweisungen des Herstellers zu verarbeiten.
7. Das Material vor der Verlegung prüfen. Reklamationen für verlegt Ware werden nicht akzeptiert.
8. Eine Quadratmeter (min. 3 qm) auf dem Boden legen, um die Gesamtwirkung nachzuprüfen. Wir empfehlen Fliesen aus mehreren Kartons zu verlegen, nach einer sorgfältigen Prüfung des Kalibers, des Farbtons und der Sortierung.

9. Der hohe Sinterungsgrad der Fliesen von Serenissima ist mit geringer Kalibertoleranz verbunden: deswegen wird eine min. 3 mm Fugenzwischen den Fliesen empfohlen.
10. Blei- oder Filzstifte auf der Oberseite der Fliesen nicht benutzen.
11. Auf den Boden für 48/72 Stunden nach der verlegung nicht treten. Das Farbspiel des Produkts ist eine Eigenschaft, die ein fähiger Fliesenleger hervorheben kann. Ein schönes aber schlecht verlegtes Produkt bietet kein ästhetisch gutes Ergebnis.
12. Wir empfehlen eine Verlegung im Viertelverband.

VERLEGEEMPFEHLUNGEN FÜR GESCHLIFFENE MATERIALIEN
Die fugenlose Verlegung des kalibrierten Produkts benötigt seitens des Fliesenlegers eine größere Aufmerksamkeit und Genauigkeit bezüglich der Planarität der Oberfläche zu verlegen bzw. der Kontinuität des Fugenbildes.

Um einen optimalen Effekt beim Verlegen zu erzielen, empfiehlt Serenissima eine min. 2 mm Fuge bei einformatigen Verlegungen und bei Formatkombinationen. Die fugenlose Verlegung, insbesondere der großen Formate, wird von den meisten Klebstoffherstellern aus den folgenden Gründen nicht empfohlen:

- Aufnahmeschwierigkeiten von eventuellen Bodenbewegungen;
- verschiedene Ausdehnung zwischen Fliesen und Mörtelbett bei

VERLEGEEMPFEHLUNGEN FÜR GESCHLIFFENE MATERIALIEN

Die fugenlose Verlegung des kalibrierten Produkts benötigt seitens des Fliesenlegers eine größere Aufmerksamkeit und Genauigkeit bezüglich der Planarität der Oberfläche zu verlegen bzw. der Kontinuität des Fugenbildes.

hoher Temperaturschwankung;

- Schwierigkeiten bei Verwirklichung von einer dauerhaften und elastischen Fuge.

Serenissima rat dringendst von einem fugenlosen Verlegen ab und lehnt jede Haftung dafür ab. Serenissima empfiehlt, die rektifizierten Fliesen mit einer Fuge von mind. 2 mm zu verlegen.

VERFUGUNG

1. Wenn kein Mörtel benützt wird, wird es empfohlen mit färbigen Fugenmassen in ähnlicher Tonalität zu verfugen, z.B. keine dunkle Fugenmasse für helle Fliesen.
2. Zuerst kleine Flächen (4-5 qm) verfugen und sofort die überflüssige Fugenmasse mit einem feuchten Lappen oder Schwamm (nur mit klarem Wasser) entfernen oder entsprechende Reinigungsmaschinen verwenden.
3. Verspachteln Sie die Fugen erst dann, wenn die Bodenfliesen begehbar sind und entfernen Sie vorher vorsichtshalber jegliche Rückstände aus den Fugenzwischenräumen.
4. Führen Sie die Spachtelarbeiten sachkundig aus und befolgen Sie dabei die Anweisungen des Planungsfachmanns, des Poliers und des Leistungsverzeichnisses.
5. Nicht legierte Zementspachtelmassen: Befreien Sie am Ende des Tages die Fliesen von den Rückständen der Verlegearbeiten mit einem feuchten Schwamm. Die Reinigung des Fußbodens nach dem Verlegen sollte, sofern der Hersteller keine anderen Angaben gemacht hat, 4-5 Tage später erfolgen (die Spachtelmasse hat so genügend Zeit, um auszuhärten); befeuchten Sie hierzu zuerst die Fugen mit Wasser und verwenden dann ein geeignetes Reinigungsmittel auf Säurebasis. Warten Sie nicht zu lange mit der Reinigung, da sie bereits nachzwei Wochen sehr viel mehr Arbeitseinsatz erfordern wird. Führen Sie die Reinigung nach dem Verlegen nicht durch, wenn die Temperatur der Fliesen erhöht ist; im Sommer sollten Sie die Reinigungsarbeiten entweder in den noch kühlen Morgen- oder Abendstunden vornehmen.

6. Epoxid- oder legierte Spachtelmassen (mit Latex etc.): Befolgen Sie sorgfältig die Anweisungen des Herstellers, da das schnelle Aushärten sehr aufwendige Säuberungsarbeiten nach sich ziehen kann, besonders wenn die Fliesenoberfläche rutschfest, rau oder strukturiert ist.

REINIGUNG

Die Dauer eines Fliesenbelages ist abhaengig von seiner Benutzung und seiner Pflege.

Wand- und Bodenfliesen richtig ausgewaehlt und verlegt sind sehr haltbar.

Es ist jedenfalls wichtig das Material zu kennen und einige einfache Regeln zu respektieren.

REINIGUNG NACH DER VERLEGUNG

Die Reinigung nach der Verlegung ist von ausschlaggebender Wichtigkeit fuer alle folgenden Arbeitsgaenge und die Pflege des Bodenbelages.

Eine Reinigung nach der Verlegung mit Putzmitteln auf saurehaltiger Basis entfernt Verlegungsreste und Schmutz der Baustelle wie Schleier, Kleber, Farbe, usw. Es ist wichtig zu wissen, dass ueber 90% der Reklamationen auf der Baustelle auf eine unzureichende oder ueberhaupt nicht erfolgte Reinigung nach dem Verlegen mit einem saeurehaltigen Reinigungsmittel zurueck zu fuehren sind. Vor der Reinigung auf Saeurebasis ist es notwendig den Bodenbelag mit Wasser nass zu machen, um die Fugen auf Zementbasis zu impregnieren. Dadurch werden die Fugen von der korrosiven Wirkung der Saeure geschuetzt. Falls die erste Reinigung erst nach der Benutzung des Bodenbelages gemacht wird, erst Putzmittel auf alkalischer Basis gegen Oel und Fett und danach Putzmittel auf Saeurebasis benutzen. Zum Schluss den Belag mit viel Wasser abwaschen und soviel wie moeglich das schmutzige Wasser entfernen. Die Reinigung nach Abschluss der Baustellenarbeiten ist nach vollstaendigem Trocknen des Zementkitts (mindestens 36-48 Stunden) vorzunehmen, unter Beobachtung der Empfehlungen des Herstellers. Diese Reinigung mit Saeurebasis Produkte, muss nur einmal gemacht werden und gibt dem Boden chromatische Gleichmaessigkeit.

UEBLICHE PFLEGE

Es wird empfohlen, neutrale Reinigungsmittel mit Wasser zu verwenden. Saeure-, Alkalisch-, Wachs- und Impregnungsmittel

UEBLICHE PFLEGE

Die Serenissima Kunden werden gebeten, vor der Materialauslieferung den Verleger oder Empfaenger ueber die in dieser Katalog enthaltenen Hinweise und Empfehlungen zu informieren. Falls diese Informationen nicht gegeben werden, wird Serenissima fuer eventuelle Probleme bei oder nach der Verlegung nicht verantwortlich sein.

Verlegung des Fliesenbelages

Verlegung des Fliesenbelages

VERLEGEHINWEISE

sowie Eisen- und Stahlschwaemme sind zu vermeiden. Falls die Fliesenoberflaeche glaezend ist, ist sie an Kratzer und Beschaedigung von solchen Mitteln noch mehr empfindlich. Fuer strukturierte Oberflaechen oder stark schmutzige Belaege ist ein Putzmittel auf alkalischer Basis empfohlen, danach mit Wasser abwaschen. Fuer grossere Oberflaechen sind Maschinen empfohlen. Man muss immer beachten, dass besondere Art von Schmutz wie Sand und Staub aufgrund des Durchgangsverkehrs von Passanten ziemlich aggressiv werden kann. Es ist deswegen wichtig am Hauseingang eine Fussmatte zu platzieren.

AUSSERORDENTLICHE PFLEGE

Falls die normalen Putzmittel in besonderen Faellen keine Wirkung haben sollten, wird von Fall zu Fall das entsprechend spezifisches Putzmittel empfohlen.

METALLISIERTE MATERIALIEN

Für die Pflege metallisierter Fliesen keine Putzmittel auf saeure oder alkalischer Basis benutzen. Nur neutrale PH Produkte verwenden. Es ist empfehlenswert, erstmal das Produkt auf einige nicht verlegten Fliesen nicht laenger als 10-15 min. zu testen. Dann immer reichlich mit Wasser abwaschen.

EMPFEHLUNGEN

Wir weisen darauf hin, nie Putzmittel auf Fluorwasserstoff Basis (HF) oder dessen Verbindung zu verwenden, inkl. Rostschutz oder Spray Fleckenferner. Der dadurch entstandene Schaden wird permanent bleiben, da alle Fliesen im Markt dagegen absolut nicht widerstandsfahig sind.

HINWEISE

Die Sauberkeitseigenschaften der Fliesen aendern sich sehr, abhaengig von Art der Verlegung, Benutzungsart, Oberflaeche und Lage. In der Regel je rauher die Fliesen sind, desto schwieriger ist es sie zu putzen. Die mit Pflege und Reinigung beauftragte Fachkraft muss bei jedem Eingriff immer eine empirische Vorabkontrolle vornehmen (moeglichst auf nicht verlegtem Material).

Bei besonders schwierigen Einsatzbedingungen, falscher Verlegung oder unsachgemaess ausgefuehrte Reinigung uebernimmt Serenissima keine Verantwortung ueber die Wirksamkeit von Reinigungs- und Pflegearbeiten.

In keinem Fall ist Serenissima fuer Ereignisse, Schaeden oder Maengel verantwortlich, die auf eine falsche Verlegung, nachlaessige Reinigung und Pflege oder auf eine ungeeignete Auswahl der verlegten Materialien und verwendete Kleber fuer die jeweilige Gebrauchbestimmung zurueckzufuehren sind. Die in diesem Abschnitt enthaltenen Informationen sind vollkommen unverbindlich.

Fuer weitere Informationen verweisen wir auf die entsprechende Dokumentation der Putzmittel Herstellern wie z.B.:

Fila Industria Chimica spa (www.filachim.com), Mapei S.p.a. (www.mapei.it), Kerakoll S.p.A. (www.kerakollgroup.com), Bonasystems Italia S.r.l. (www.bonasystemstalia.it), Faber Chimica S.r.l. (www.faberchimica.com), Periscopio s.r.l. (www.periscopiosoluzioni.com).

BEHANDLUNG VON POLIERTEN UND ANGESCHLIFFENEN MATERIALIEN

Durch das Anschleifen oder Polieren wird der oberste Teil der Fliese entfernt. Dieses Verfahren kann, auch bei Materialien mit fast keiner Wasseraufnahme, oberflächliche Porosität verursachen und deswegen, bei besonderem Schmutz, Schwierigkeiten in der Reinigung bringen. Serenissima empfiehlt den Boden nach der Verlegung mit einem Putzmittel auf Saeurebasis zu waschen, damit die Flecken nicht aufgenommen werden und die Feinsteinzeugfliesen technisch und esthaetisch unveraendert bleiben.

Jegliche Behandlung, die vom Hersteller vor der Verlegung gemacht werden sollte, wird durch die erste Reinigung auf Saeurebasis komplett entfernt. Deswegen kann kein Fleckschutz garantiert werden.

PRODOTTI PER LA PULIZIA E LA MANUTENZIONE (*)

CLEANING AND MAINTENANCE PRODUCTS (*) - PRODUITS DE NETTOYAGE ET D'ENTRETIEN (*) - PRODUKTE ZUR REINUNG UND PFLEGE (*)

Salvo diversa indicazione in tabella, per l'utilizzo dei detergenti in elenco seguire attentamente le indicazioni riportate sulle confezioni.

Unless otherwise indicated in the table, when using the detergents listed, follow the instructions on the pack carefully. Sauf mention contraire dan le tableau, pour l'utilisation de détergents repris dans la liste, suivre attentivement les recommandations d'usage figurant sur l'emballage du produit. Solange die Tabelle keine anderweitigen Angaben enthält, befolgen Sie bei der Verwendung von Reinigungsmitteln sorgfältig die Anweisungen auf den Verpackungen.

Tipo di sporco Type of dirt Type de salete Schmutzart	Tipo di detergente Type of detergent Type de salete Art des reinigungsmittels	Nome detergenti Name of detergent Nom du detergent Name des reinigungsmittels	Produttore Manufacturer Fabricant Hersteller
Cemento, calce, stucchi cementizi, ruggine Cement, lime, cement-based grouts, rust Ciment, chaux, enduits de ciment, rouille Zement, Kalk, Zementspachtelmasse, Rost	A base acida Acid-based A base acide Auf Säurebasis	DETERDEK DELTA PLUS CEMENT KERANET XTREME GRES CLEANER BONA CLEAN	FILA KERAKOLL FABER CHIMICA MAPEI PERISCOPIO BONASYSTEM
Stucco epossidico Epoxy-based grouts Mastic époxy résiduelle Reste von Epoxidfugenmaterial	A base alcalina Alkali-based A base alcaline Auf alkalischer Basis	FILA CR10 FUGALITE GRAFFITI REMOVER KERAPOXY XTREME EPOXY CLEANER BONA DECON	FILA KERAKOLL FABER CHIMICA MAPEI PERISCOPIO BONASYSTEM
Vino, caffè, bibite, succhi di frutta Wine, coffee, soft drinks, fruit juice Vin, café, boissons, jus de fruits Wein, Kaffee, Getränke, Fruchtsäfte	Polifunzionali, a base alcalina Multi-purpose, alkali-based Multifonction, à base alcaline Alkalische Allzweckreiniger	FILA PS87 COLOURED STAIN REMOVER XTREME ALCALINE BONA DECON	FILA FABER CHIMICA PERISCOPIO BONASYSTEM
Pneumatici Tyre marks Pneumatiques Reifenschmutz	A base alcalina Alkali-based A base alcaline Auf alkalischer Basis	FILA PS87 GRAFFITI REMOVER XTREME ALCALINE BONA DECON	FILA FABER CHIMICA PERISCOPIO BONASYSTEM
Cere, grassi Wax, fats Cires, graisses Wachs, Fett	A base solvente Solvent-based A base de solvant Auf Lösungsmittelbasis	FILA SOLV WAX REMOVER XTREME EPOXY CLEANER BONA DECON	FILA FABER CHIMICA PERISCOPIO BONASYSTEM
Patine lasciate da detergenti Residue left by detergents Patines laissées par des nettoyeurs Schleier aus Reinigungsmittelrückständen	Polifunzionali, a base alcalina Multi-purpose, alkali-based Multifonction, à base alcaline Alkalische Allzweckreiniger	FILA PS87 THE CLEANER XTREME ALCALINE BONA DECON	FILA FABER CHIMICA PERISCOPIO BONASYSTEM
Segni di matita, segni metallici Pencil marks, metallic marks Traces de crayon, traces métalliques Bleistift- und metallische Rückstände	A base acida Acid-based A base acide Auf Säurebasis	DETERDEK CEMENT REMOVER XTREME GRES CLEANER BONA CLEAN	FILA FABER CHIMICA PERISCOPIO BONASYSTEM
Inchiostri, pennarello Ink, marker pens Encres, marqueurs Tinte, Filzstift	A base alcalina Alkali-based A base alcaline Auf alkalischer Basis	FILA PS87 - FILA SR95 COLOURED STAIN REMOVER XTREME EPOXY CLEANER BONA DECON	FILA FABER CHIMICA PERISCOPIO BONASYSTEM
Pulizie quotidiane Everyday cleaning Nettoyage quotidien Tägliche Reinigung	Neutro o alcalino Neutral or alkaline Neutre ou alcalin Neutral- oder alkalische Reiniger	FILA CLEANER FLOOR CLEANER EVERY FLOOR BONAMAIN +	FILA FABER CHIMICA PERISCOPIO BONASYSTEM

(*) Eseguire sempre test preventivo sulle piastrelle prima dell'uso, in particolare su prodotti lappati o levigati.

(*) Always do a test in advance on the tiles before use, particularly on Lapper or Ground products.

(*) Toujours procéder à un essai sur les carreaux avant l'utilisation, surtout pour les articles rodés ou polis.

(*) Vor der Benutzung sollten Sie immer erst einen prophylaktischen Probeauftrag durchführen, besonders auf geläpften oder polierten Fliesen.

(*) Рекомендуется всегда проводить предварительное испытание перед использованием, особенно на лаппатированной или полированной плитке.

BONASYSTEMS Italia S.r.l.
Via Borgo S. Chiara, 29 - 30020 Torre di Mosto (VE) ITALY
Tel +39 0421 325691 - www.bonasytemsitalia.it

PERISCOPIO s.r.l.
Sede legale. Via Rainusso n. 90 - 41124 Modena
Sede operativa. Via S.Maria 11 - 41013 Castelfranco Emilia (MO)
Tel. +39 335360913 - www.periscopiosoluzioni.com

FABER CHIMICA S.r.l.
Via G. Ceresani, 10 - Località Campo d'Olmo - 60044 Fabriano (AN) - ITALY
Tel. +39 0732-627178 - www.faberchimica.com



KERAKOLL S.p.A.
Via dell'Artigianato 9 - 41049 Sassuolo (MO) - ITALY
Tel +39 0536 816 511 - www.kerakollgroup.com

FILA Industria Chimica S.p.A.
Via Garibaldi, 32 - 35018 San Martino di Lupari (Padova) - ITALY
Tel. 049.946.73.00 - www.filachim.com

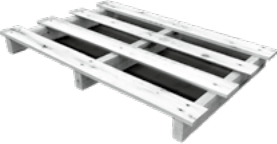
MAPEI S.p.A.
Via Cafiero 22 - 20153 Milano - ITALY
Tel. +39 02-37673 - www.mapei.it

PALLET MINI	
	PALLET 50x80 cm - € 6,00 Profondità 50 cm / Larghezza 80 cm
	PALLET 84x84 cm - € 6,00 Profondità 84 cm / Larghezza 84 cm

EUROPALLET O SIMIL EURO	
	PALLET 80x120 cm - € 10,00 Profondità 120 cm / Larghezza 80 cm
	PALLET 84x124 cm - € 10,00 Profondità 124 cm / Larghezza 84 cm
	PALLET 94x122 cm - € 10,00 Profondità 122 cm / Larghezza 94 cm

PALLET BIG	
	PALLET 110x110 cm - € 18,00 Profondità 110 cm / Larghezza 110 cm
	PALLET 104x112 cm - € 18,00 Profondità 112 cm / Larghezza 104 cm
	PALLET 125x125 cm - € 18,00 Profondità 125 cm / Larghezza 125 cm
	PALLET 122x140 cm - € 18,00 Profondità 140 cm / Larghezza 122 cm
	PALLET 100x180 cm - € 18,00 Profondità 180 cm / Larghezza 100 cm
	PALLET PARIETALI 100x100 cm - € 18,00 Profondità 120 cm / Larghezza 102 cm / Altezza 53 cm
	PALLET PARIETALI 120x120 cm - € 18,00 Profondità 122 cm / Larghezza 143 cm / Altezza 56 cm
	PALLET PARIETALI 20x180-26x180-80x180 cm - € 18,00 Profondità 184 cm / Larghezza 100 cm / Altezza 46 cm

CAVALLETTO	
	CAVALLETTO 120x120/100x100 cm - € 35,00 Profondità 60 cm / Larghezza 125 cm / Altezza 145 cm
	CAVALLETTO 80x180 cm - € 35,00 Profondità 60 cm / Larghezza 185 cm / Altezza 105 cm

CONDIZIONI GENERALI DI VENDITA

GENERAL TERMS OF SALE
CONDITIONS GENERALES DE VENTE
ALLGEMEINE VERKAUFSBEDINGUNGEN

1. NORMATIVA CONTRATTUALE - Le presenti condizioni generali, salvo eventuali modificazioni o deroghe concordate per iscritto, disciplinano tutti i contratti di vendita tra noi e l'acquirente, quindi tanto il contratto concluso con l'accettazione del presente ordine che qualsiasi contratto futuro relativo alle forniture dei prodotti della nostra società ordinati con successive e distinte commissioni.
2. FORNITURE - Il prezzo qui specificato si intende al netto di spese di trasporto, IVA ed eventuali diritti di dogana; per merce resa franco ns. stabilimento.
3. ORDINI - Il Committente si obbliga a mantenere ferma la proposta d'ordine rilasciata a personale commerciale della ns. società. Ogni ordine trasmesso dai ns. Agenti è sempre raccolto "SALVO APPROVAZIONE DELLA CASA", per cui ci riserviamo di non accettare o modificare l'ordine stesso. Quanto sopra vale anche per eventuali cessioni gratuite per sala mostra. Prima di evadere gli ordini, l'azienda si riserva la facoltà di richiedere informazioni commerciali.
4. CONSEGNE - I termini di consegna non sono mai impegnativi; comunque, il mancato espletamento dell'ordine se confermato o il ritardo nella sua esecuzione escludono ogni ns. responsabilità da cause a noi imputabili, quali impedimenti o difficoltà nei trasporti, scioperi, serrate, impossibilità o anche soltanto difficoltà di tempestivo approvvigionamento delle materie prime. Il committente, quindi, non può in nessun caso chiedere la risoluzione del contratto o esigere indennizzi da eventuali danni diretti o indiretti per il ritardo nella consegna.
5. SCELTE - Il materiale verrà consegnato nelle scelte ordinate. Pertanto, le richieste di determinate percentuali di scelta verranno intese come semplici indicazioni e soddisfatte compatibilmente con le rese di produzione.
6. TRASPORTO - La merce viaggia a rischio e pericolo del Committente anche se resa franco destino e la ns. responsabilità cessa con la consegna al vettore, per tanto, i reclami per eventuali ammanchi o rotture dovranno essere rivolti esclusivamente a questi.
7. PREZZI - Ci riserviamo la facoltà di modificare i prezzi del presente listino con un preavviso di 30 (trenta) giorni.
8. PAGAMENTI - I pagamenti devono pervenire presso la ns. sede. L'accettazione da parte ns. di effetti o assegni emessi fuori piazza o comunque il convenuto pagamento a mezzo tratte non deroga tale condizione. Le fatture non contestate entro 8 (otto) giorni dal ricevimento si intendono accettate. I pagamenti dovranno avvenire nei modi e nei termini pattuiti nella ns. commissione. In caso di ritardato pagamento di somme a noi dovute, è ns. facoltà sospendere le forniture e annullare i rapporti in corso. Gli interessi per ritardato pagamento dovranno essere convenuti espressamente con tassi da definire. In difetto verranno applicati gli interessi moratori di legge.
9. CONTESTAZIONE PER VIZI - Eventuali contestazioni per vizi qualsiasi sia palesi sia occulti della merce oggetto della fornitura devono essere inoltrate alla ns. sede a mezzo raccomandata con avviso di ricevimento entro 8 (otto) giorni dal ricevimento della merce. In ogni caso, prima di procedere alla posa del materiale ceramico compravenduto sarà onere dell'acquirente e/o del cliente finale a cui tale obbligazione dovrà essere contrattualmente estesa, verificare la sussistenza o meno di vizi e/o difetti palesi e ciò al fine di non aggravare il danno. Eventuali reclami che dovessero riguardare il materiale già in opera verranno pertanto respinti. La posa in opera determinerà rinuncia alla garanzia per vizi palesi della merce fornita e comunque integrerà quanto disposto dall'art.1227 c.c.. E' espressamente esclusa la garanzia per la merce classificata di seconda o terza scelta, blocchi o partite occasionali. Offerte, transazioni, accrediti concessi dai ns. Agenti o intermediari non sono validi se non confermati per iscritto dalla ns. sede. I nostri campioni sono soltanto indicativi e vengono da noi presentati al solo scopo di fornire al cliente indicazioni di massima del prodotto.
10. SOLVE ET REPETE - Nessuna eccezione, salvo quelle di nullità, annullabilità e rescissione del contratto, può essere opposta dall'acquirente al fine di ritardare od evitare il pagamento.
11. RISERVATO DOMINIO - La vendita della merce viene effettuata con la clausola del riservato dominio, sicché la proprietà della stessa passerà all'acquirente solo con l'integrale ed effettivo pagamento del prezzo. Il mancato pagamento anche di una sola rata produrrà lo scioglimento del contratto con la facoltà di esigere l'immediato pagamento di tutte le rate anche non scadute overo l'immediata restituzione della merce. In tal caso le somme versate resteranno acquisite al venditore a titolo di indennità.
12. CLAUSOLA COMPROMISSORIA - Ad eccezione delle controversie inerenti il pagamento del prezzo ed alle relative azioni esercitate in via monitoria o nel giudizio ordinario, che rimangono di competenza dell'autorità giurisdizionale italiana, qualunque altra controversia che dovesse insorgere in ordine alla conclusione e/o esecuzione e/o risoluzione e/o interpretazione del presente contratto sarà devoluta ad un collegio di tre arbitri, nominati uno da ciascuna delle parti, ed il terzo di comune accordo o, in caso di disaccordo, dal Presidente della C.C.I.A.A. di Reggio Emilia, a richiesta della parte più diligente. La parte che intende avviare l'arbitrato deve comunicarlo all'altra parte con lettera raccomandata contenente la nomina del proprio arbitro e la sua accettazione. L'altra parte dovrà nominare il proprio arbitro nel termine di 15 giorni dalla data di ricezione della raccomandata, comunicando tale nomina e la relativa accettazione entro il termine indicato. In difetto falta parte potrà richiedere la nomina del secondo arbitro al Presidente della C.C.I.A.A. di Reggio Emilia. Gli arbitri decideranno secondo diritto e nel rispetto del principio del contraddittorio; il lodo dovrà essere deliberato nel termine di 90 giorni decorrenti dalla data di accettazione dell'ultimo arbitro. L'arbitrato avrà sede in Reggio Emilia.
13. FORO COMPETENTE E LEGGE APPLICABILE - Per qualsiasi controversia è esclusivamente competente il Foro di Reggio Emilia e la legge applicabile è esclusi vamente quella italiana.
14. EFFETTIVITA' DI CIASCUNA CONDIZIONE - Le condizioni generali di vendita sopra riportate non devono assolutamente intendersi come clausole di puro stile. Esse sono effettive e rappresentano fedelmente la volontà negoziale delle parti.
15. RICEZIONE MERCE - Alla ricezione della merce, il cliente è tenuto a verificare che il prodotto consegnato sia conforme a quanto dichiarato nel d.D.T. (Documento di trasporto). Non si accettano reclami per materiale consegnato in cantiere in difformità. Da quanto riportato nel documento stesso. Qualora fosse riscontrata difformità, il gruppo romani si assumerà. I costi di trasporto per l'eventuale sostituzione/integrazione della quantità di prodotto non conforme. Per ogni richiesta di reso dovuta ad errori di ordine, rinuncia da parte del cliente o comunque per motivi non imputabili all'azienda. Sarà richiesto un contributo pari al 10% del valore della merce resa.

1. CONTRACTUAL REGULATIONS – Subject to possible modifications or variations agreed in writing, these general conditions govern all sales contracts between us and the purchaser, and therefore both the contract entered into with acceptance of this order and any future contracts relating to supplies of our company's products ordered with subsequent and separate commissions.
2. SUPPLIES - The price set forth herein is understood as net of transport costs, VAT and any customs duties, for goods delivered ex works our factory.
3. ORDERS - The Principal undertakes to maintain as valid the order proposal issued to our company's sales personnel. Each order sent by our Agents is always accepted "SUBJECT TO COMPANY APPROVAL", and we therefore reserve the right not to accept or modify the order itself. The above also holds true for any free-of-charge transfers for the showroom. Before fulfilling orders, the company reserves the right to request sales information.
4. DELIVERIES - Delivery terms are never binding; in any event, we shall not be deemed responsible for any delivery or performance delays of orders, where confirmed, due to events attributable to us, such as obstacles or difficulties in transport, strikes, lockouts, impossibility or even only difficulty in prompt procurement of raw materials. The principal, therefore, cannot in any case request the termination of the contract or claim compensation for any direct or indirect damages due to delay in delivery.
5. GRADES - The material will be delivered in the grades available. Therefore, requests for certain percentages of grades will be understood as simple indications and fulfilled according to production outputs.
6. TRANSPORT - Goods travel at the Principal's own risk even if delivered carriage paid and our responsibility ceases with delivery to the carrier; therefore, com plaints about any shortfalls or breakages must therefore be made exclusively to the latter.
7. PRICES – We reserve the right to modify the prices in the price-list with 30 (thirty) days' advance notice.
8. PAYMENTS - Payments must be made to our head office. Our acceptance of bills or non-locally issued cheques or in any case agreed payment by banker's drafts does not create an exception to this condition. Invoices not contested within 8 (eight) days from receipt are understood as accepted. Payments must be made in the ways and under the terms agreed in our commission. In the case of late payment of sums owed to us, we have the right to suspend supplies and cancel the relationships in progress. Interest for late payment must be expressly agreed with rates to be defined. In the absence of this, legal default interest will be applied.
9. CONTESTED DEFECTS - Any contested defects of the goods that are the subject of the supply, whether apparent or hidden, must be forwarded to our head office by registered letter with return receipt within 8 (eight) days from receipt of the goods. In any case, before proceeding with laying the ceramic material pur chased, it will be the responsibility of the purchaser and/or of the end customer, to whom this obligation must be contractually extended, to check the existence of apparent faults and/or defects, in order not to worsen the damage. Any complaints concerning material already laid will therefore be rejected. Laying of the material will constitute waiver of warranty for apparent defects in the goods supplied and in any case will supplement the provisions of Article 1227 of the Italian Civil Code. Warranty for goods classified as second or third grade, occasional lots or batches is expressly excluded. Offers, transactions and credits granted by our Agents or intermediaries are not valid unless confirmed in writing by our head office. Our samples are only indicative and are presented by us for the sole purpose of providing the client with a general idea of the product.
10. SOLVE ET REPETE - No exception, save that of nullity, possibility of cancellation, and termination of the contract, can be claimed by the purchaser with the pur pose of delaying or avoiding payment.
11.TITLE RETENTION– Sale of the goods is carried out with the title retention clause, so that ownership of the same shall pass to the purchaser only with the complete and effective payment of the price. Failure to pay even one single instalment will cause termination of the contract with the right to demand immediate payment of all instalments even if not expired or the immediate return of the goods. In the latter case the seller shall retain the sums paid, by way of indemnity.
12. ARBITRATION CLAUSE - Except for disputes relating to payment of the price and the relative actions brought in summary proceedings or in the ordinary court, which fall under the competence of the Italian legal authorities, any other dispute that may arise concerning the conclusion and/or execution and/or termination and/or interpretation of this contract shall be transferred to a board of three arbitrators, one appointed by each of the two parties and the third by common agreement or, in the case of disagreement, by the Chairman of the Reggio Emilia Chamber of Commerce, Industry, Agriculture and Small Business (C.C.I.A.A.), by request of the most diligent party. The party which intends to start up the arbitration must notify this to the other party with a registered letter containing the appointment of its own arbitrator and his/her acceptance. The other party must appoint its own arbitrator within 15 days from the date of receipt of the registered letter, notifying this appointment and relative acceptance within the time-limit indicated. If this should not be done the other party may request the Chairman of the Reggio Emilia C.C.I.A.A. to appoint the second arbitrator. The arbitrators shall decide according to law and in observance of the adversarial nature of the proceedings; the award must be resolved on within a time-limit of 90 days starting from the date of acceptance of the last arbitrator. The arbitration will take place in Reggio Emilia.
13. COURT OF JURISDICTION AND GOVERNING LAW – For any dispute the Court of Reggio Emilia has exclusive jurisdiction and the governing law is exclusively Italian law.
14. EFFECTIVENESS OF EACH CONDITION - The above general conditions of sale must under no circumstances be understood merely as standard clauses. Theyare effective and faithfully represent the contractual intent of the parties.
15. GOODS RECEIPT – Upon receipt of the goods, the customer has to verify that the material is compliant to what declared in the transport document. Complaints for material that does not correspond to what declared in the transport document that has already been delivered to job site will not be accepted. Gruppo romani will be responsible for cost of transport and eventual replacement or supply of material that has been found to be not compliant to what declared in the transport document. For any request for goods to be returned due to order errors, refusal by the customer or in any case for reasons not attributable to the company, a contribution of 10% of the value of the goods returned will be required.

1. DISPOSITIONS CONTRACTUELLES - Sauf modifications ou dérogations éventuelles convenues par écrit, les présentes conditions générales régissent tous les contrats de vente entre nous et l'acheteur, autrement dit tant le contrat conclu lors de l'acceptation de la présente commande que tout contrat futur relatif à la fourniture de produits de notre société demandés à l'occasion de commandes successives et distinctes.

2. FOURNITURES - Le prix indiqué ici s'entend hors frais de transport, TVA et éventuels droits de douane, pour des marchandises départ usine.

3. COMMANDES - L'acheteur s'engage à ne pas se rétracter de la proposition de commande faite au personnel commercial de notre société.

Les commandes sont toujours transmises par nos agents « SOUS RESERVE DE L'APPROBATION PAR NOTRE SOCIÉTÉ », avec la faculté d'accepter ou de modifier la commande. Les indications ci-dessus s'appliquent également en cas de cessions gratuites à des salles d'exposition. Avant de traiter les commandes, l'entreprise se réserve le droit de demander des informations commerciales.

4. LIVRAISONS - Les délais de livraison n'ont pas valeur contractuelle. L'inexécution d'une commande déjà confirmée ou un retard de livraison excluent toute responsabilité de notre part en cas de causes qui nous seraient imputables, telles que des empêchements ou des difficultés de transport, des grèves, des lockout, des impossibilités ou même des difficultés d'approvisionnement en temps voulu en matières premières. L'acheteur ne peut donc en aucune façon demander la résiliation du contrat ou des indemnités du fait d'éventuels dommages directs ou indirects liés à un retard de livraison.

5. CHOIX - Le matériau livré sera prélevé parmi les différents choix de produits disponibles. Par conséquent, au cas où des pourcentages de choix de produits spécifiques seraient demandés, ceux-ci seront considérés comme de simples indications et satisfaits dans la limite des quantités produites.

6. TRANSPORT - La marchandise, même lorsqu'elle est fournie franco destination, voyage aux risques et périls de l'acheteur, notre responsabilité cessant au moment de la remise au transporteur. C'est pourquoi les réclamations pour d'éventuels matériaux manquants ou abîmés devront être adressées exclusivement à celui-ci.

7. PRIX - Nous nous réservons le droit de modifier les prix de la présente liste de prix avec un préavis de 30 (trente) jours.

8. PAIEMENTS - Les paiements doivent parvenir au siège de notre société. L'acceptation d'effets ou de chèques émis hors place ou le paiement, après accord préalable, moyennant plusieurs traites, n'invalide pas cette condition. Les factures n'ayant pas fait l'objet d'une réclamation dans les 8 (huit) jours après leur réception s'entendent acceptées. Les paiements devront être effectués selon les modalités et dans les délais convenus dans le contrat de fourniture. En cas de retard de paiement, notre société est en droit de suspendre les fournitures et d'annuler les contrats en cours. Les intérêts liés aux retards de paiement et leurs taux devront être expressément convenus. À défaut, les intérêts moratoires légaux s'appliqueront.

9. RÉCLAMATIONS POUR VICES - Les éventuelles réclamations pour vices apparents ou cachés de la marchandise faisant l'objet de la fourniture doivent être adressées à notre siège par lettre recommandée AR dans un délai maximum de 8 (huit) jours après réception de la marchandise. Quoi qu'il en soit, avant de procéder à la pose du matériau céramique vendu, il incombe à l'acheteur et/ou au client final, à qui cette obligation devra être contractuellement étendue, de vérifier l'existence ou non de vices et/ou de défauts apparents afin de ne pas aggraver le préjudice. Toute réclamation concernant le matériau déjà posé sera par conséquent rejetée. La pose du matériau entraîne le renoncement à la garantie pour vices apparents de la marchandise fournie et intègre les dispositions de l'art. 1227 du Code civil italien. La garantie est expressément exclue pour les deuxième ou troisième choix de marchandises, les blocs ou les lots occasionnels. Les offres spéciales, transactions, crédits consentis par nos agents ou intermédiaires n'ont aucune validité s'ils n'ont pas été confirmés par écrit par notre siège. Nos échantillons sont fournis à titre indicatif et ne sont présentés que dans le but de fournir au client des indications générales sur le produit.

10. SOLVE ET REPETE - L'acheteur ne peut se prévaloir d'aucune exception, sauf celles de nullité, d'annulation et de rupture du contrat, pour retarder ou éviter le paiement.

11. RÉSERVE DE PROPRIÉTÉ - La vente des marchandises inclut une clause de réserve de propriété, de sorte que les marchandises ne deviendront la propriété de l'acheteur qu'après le paiement intégral et effectif du prix. Le non-paiement ne serait-ce que d'une seule traite entraînera la résiliation du contrat, sans préju di ce du droit au paiement immédiat de toutes les traites, y compris celles qui ne seraient pas encore arrivées à échéance, ou la restitution immédiate de la mar chandise. Dans ce cas, les sommes versées seront acquises au vendeur à titre d'indemnités.

12. CLAUSE COMPROMISSOIRE - Exception faite des litiges inhérents au paiement du prix et aux actions correspondantes exercées à titre d'avertissement et dans le jugement ordinaire, qui restent de la compétence de l'autorité juridictionnelle italienne, tout autre litige en lien avec la conclusion et/ou l'exécution et/ou la résolution et/ou l'interprétation du présent contrat sera soumis à un collège arbitral composé de trois membres, chaque partie en nommant un et le dernier étant nommé d'un commun accord ou, dans l'éventualité d'un désaccord, par le Président de la C.C.I.A.A. de Reggio Emilia à la demande de la partie la plus diligente. La partie souhaitant demander un arbitrage doit en informer l'autre par une lettre recommandée indiquant l'arbitre nommé et l'acceptation par celui-ci. L'autre partie devra nommer un arbitre dans un délai de 15 jours à compter de la date de réception de la lettre recommandée, en communiquant cette nomination et son acceptation dans le délai indiqué. À défaut, l'autre partie pourra demander au Président de la C.C.I.A.A. de Reggio Emilia de procéder à la nomination du deuxième arbitre. Les arbitres baseront leur décision sur les dispositions réglementaires, dans le respect du principe du contradictoire. La sentence devra étreémise dans un délai de 90 jours à compter de la date d'acceptation par le dernier arbitre. L'arbitrage aura lieu à Reggio Emilia.

13.TRIBUNAL COMPÉTENT ET LÉGISLATION APPLICABLE - En cas de litige, le Tribunal de Reggio Emilia sera seul compétent et la législation italienne sera la seule à s'appliquer.

14.EFFECTIVITÉ DE CHAQUE CONDITION - Les conditions générales de vente indiquées ci-dessus ne doivent en aucune façon être considérées comme des clau ses de style. Elles sont effectives et représentent fidèlement la volonté commerciale des parties.

15. RECEPTION DES MARCHANDISES - Au moment de réception de la marchandise, le client doit contrôler que le produit reçu soit conforme à ce qu'il y a marqué dans le Bulletin de livraison. L'usine n'acceptera pas de réclamation pour du matériel livré sur le chantier qui n'est pas conforme à ce qu'il y a écrit dans le bulletin de livraison. Lorsqu'il y aura le constat de marchandise non conforme, gruppo romani prendra charge des frais de transport pour l'éventuel remplacement et/ou intégration de la quantité de produit non conforme. Pour toute demande de retour en raison d'erreurs de commande, de renonciation de la part du client ou pour toute autre raison non imputable à la société, une contribution de 10 % de la valeur de la marchandise retournée sera demandée au client.

1. VERTRAGSBEDINGUNGEN - Diese allgemeinen Bedingungen regeln mit Ausnahme eventuell schriftlich vereinbarter Änderungen oder Abweichungen alle Verkaufsverträge zwischen uns und dem Käufer, d.h. sowohl den abgeschlossenen Vertrag mit der Annahme der vorliegenden Bestellung, als auch jeden zukünftigen Vertrag, der sich auf die Lieferungen von Produkten unserer Gesellschaft bezieht, die an späteren Zeitpunkten mit gesonderten Aufträgen bestellt werden.
2. LIEFERUNGEN - Der hier aufgeführte Preis ist der Nettopreis ohne Transportkosten, Mehrwertsteuer und eventuelle Zollgebühren und gilt für Warenübergabe bei unserem Produktionswerk.
3. BESTELLUNGEN - Der Auftraggeber verpflichtet sich, die Gültigkeit seines an das Vertriebspersonal unserer Gesellschaft erteilten Bestellvorschlages aufrechtzu erhalten. Jede von unseren Vertretern zugesandte Bestellung wird immer „VORBEHALTLICH UNSERER ZUSTIMMUNG“ entgegengenommen, d.h. wir behalten uns vor, die Bestellung nicht anzunehmen oder sie zu ändern. Dies gilt auch für eventuelle kostenlose Abtretungen für Ausstellungsräume. Vor der Erledigung der Bestellungen behalten wir uns vor, geschäftliche Informationen einzuholen.
4. LIEFERUNGEN - Die Liefertermine sind nie verbindlich; die Nichterledigung einer bestätigten Bestellung oder ihre verspätete Ausführung schließt in jedem Fall unsere Verantwortung wegen auf uns zurückzuführende Ursachen, wie Verhinderung oder Schwierigkeiten bei Transporten, Streiks, Arbeiteraussperrungen, nicht mögliche Beschaffung oder auch nur Schwierigkeiten bei der rechtzeitigen Beschaffung der Rohmaterialien, vollkommen aus.
5. SORTIERUNG - Das Material wird in den verfügbaren Sorten geliefert. Forderungen bestimmter Sortenanteile werden als einfache Hinweise entgegen genommen und je nach den Produktionsergebnissen erfüllt.
6. TRANSPORT - Die Waren werden auf Risiko und Gefahr des Auftraggebers verschickt, auch wenn sie frei Haus verkauft werden, und unsere Verantwortung endet bei der Übergabe an den Frachtführer. Deshalb sind Reklamationen für eventuelle Fehlmengen oder Brüche ausschließlich an die Frachtführer zu richten.
7. PREISE – Wir behalten uns das Recht vor, die Preise dieser Preisliste mit einem Vorbescheid von 30 (dreißig) Tagen zu ändern.
8. ZAHLUNGEN - Die Zahlungen müssen bei unserer Niederlassung eingehen. Unsere Entgegennahme auswärtig ausgestellter Wertpapiere oder Schecks bzw. sonst vereinbarte Bezahlungen mittels Tratte sind keine Abweichungen von dieser Bedingung. Rechnungen, die nicht innerhalb von 8 (acht) Tagen ab Empfang beanstandet werden, gelten als akzeptiert. Die Zahlungen müssen in der Art und Weise und an den Fälligkeiten erfolgen, die in unseren Aufträgen angegeben sind. Bei verspäteter Bezahlung uns schuldiger Beträge sind wir berechtigt, die Lieferungen einzustellen und die laufenden Geschäftsbeziehungen abzubrechen. Der Prozentwert der Zahlungsverzugszinsen ist ausdrücklich zu vereinbaren. Andernfalls werden die gesetzlichen Verzugszinsen berechnet.
9. MÄNGELANZEIGE - Eventuelle Beanstandungen aufgrund irgendwelcher sowohl erkennbarer als auch verborgener Fehler an den zum Lieferumfang gehörenden Waren sind per Einschreibebrief mit Empfangsbescheinigung innerhalb von 8 (acht) Tagen ab Wareneingang an unsere Niederlassung zu senden. Der Käufer und/ der Endkunde ist in jedem Fall in die vertragliche Verpflichtung einzubinden, das erworbene keramische Material vor der Verlegung auf ggf. vorhandene er kennbare Fehler und/oder Mängel zu prüfen, um den Schaden nicht zu verschlimmern. Eventuelle Reklamationen für bereits verlegtes Material werden daher zurückgewiesen. Die Verlegung führt zum Verzicht auf die Garantie für erkennbare Fehler der gelieferten Waren und integriert in jedem Fall die Bestimmungen im Art. 1227 des ital. ZGB. Für Waren der zweiten und dritten Sorte, sowie für Blocklieferungen oder Sonderpartien ist die Garantie ausdrücklich ausgeschlossen. Angebote, Transaktionen und Vergütungen, die von unseren Vertretern oder von Vermittlern erteilt werden, sind nicht gültig, wenn sie nicht schriftlich von unserer Niederlassung bestätigt werden. Unsere Muster gelten nur richtungsweisend und werden von uns nur vorgelegt, um den Kunden generelle Produktangaben zuliefern.
10. KLAUSEL, SOLVE ET REPETE - Keine Einwände, ausgenommen die Nichtigkeit, Annullierbarkeit und Rückgängigmachung des Vertrags, können vom Käufer erhoben werden, um die Zahlung zu verzögern oder zu vermeiden.

11. EIGENTUMSVORBEHALT - Der Warenverkauf erfolgt mit der Eigentumsvorbehaltsklausel, d.h. das Eigentum der Waren geht erst auf den Käufer über, nachdem der Preis vollständig und effektiv bezahlt wurde. Die Nichtbezahlung auch nur einer Rate führt zur Vertragsauflösung mit Berechtigung zur Forderung der sofortigen Bezahlung aller auch noch nicht fälligen Raten oder der sofortigen Rückerstattung der Waren. In diesem Fall werden die bezahlten Beträge vom Verkäufer als Entscheidung einbehalten.

12. SCHIEDSKLAUSEL - Mit Ausnahme der Streitigkeiten in Bezug auf die Zahlung des Preises und der entsprechend getroffenen Maßnahmen zur Mahnung oderim ordentlichen Verfahren, für welche die italienische Gerichtsbehörde zuständig ist, wird jede sonstige Streitigkeit, die sich aus dem Abschluss und/oder aus der Ausführung und/oder Auflösung und/oder Auslegung des vorliegenden Vertrages ergeben sollte, einem Schiedskollegium mit drei Schiedsrichtern anvertraut, von denen zwei von jeweils einer der Parteien ernannt werden und der dritte Schiedsrichter in beiderseitigem Einverständnis, oder bei Uneinigkeit vom Vorsitzenden der Handels-, Industrie-, Handwerks- und Landwirtschaftskammer in Reggio Emilia nach Beantragung durch die sorgfältigere Partei. Die Par tei, die das Schiedsgericht einzuschalten beabsichtigt, muss die andere Partei per Einschreibebrief davon in Kenntnis setzen und darin den von ihr ernannten Schiedsrichter und dessen Annahmeerklärung bekannt geben. Die andere Partei muss ihren Schiedsrichter innerhalb von 15 Tagen ab Empfang des Einschreibebriefes ernennen und diese Ernennung mit dazugehöriger Annahmeerklärung innerhalb der angegebenen Frist mitteilen. Andernfalls kann die andere Partei die Ernennung des zweiten Schiedsrichters beim Vorsitzenden der Handels-, Industrie-, Handwerks- und Landwirtschaftskammer in Reggio Emilia beantragen. Die Schiedsrichter entscheiden laut Gesetz und unter Einhaltung des Verhandlungsgrundsatzes; der Schiedsspruch ist innerhalb von 90 Tagen ab dem Datum der Annahmeerklärung des letzten Schiedsrichters zu beschließen. Der Sitz des Schiedsgerichts wird in Reggio Emilia sein.

13. GERICHTSSTAND UND ANWENDBARES RECHT - Für alle Streitigkeiten ist ausschließlich der Gerichtsstand Reggio Emilia zuständig und allein das italienische Recht ist anwendbar.

14. WIRKSAMKEIT JEDER BEDINGUNG - Die oben aufgeführten allgemeinen Verkaufsbedingungen dürfen keinesfalls als reine Stilklauseln betrachtet werden. Sie sind wirksam und entsprechen getreu dem rechtsgeschäftlichen Willen der Parteien.

15. WARENEMPFANG - Nach erhalt der ware verpflichtet sich der kunde, die gelieferte ware zu kontrollieren, insbesondere die übereinstimmung mit den daten desieferscheins. Für auf die baustelle gelieferten material, das die angaben des lieferscheins nicht entspricht wird keine reklamation akzeptiert. Wenn die gelieferte ware die daten des lieferscheins nicht entspricht wird gruppo romani das material austauschen bzw. Ersetzen und die transportkosten bis zu dem kunden tragen. Für jede forderung auf rückerstattung auf grund von bestellungsfehlern, verzicht durch den kunden oder aus nicht dem unternehmen zuzuschreibenden gründen, wird eine kostenbeteiligung von 10% des werts der rückerstatteten ware verlangt.

SERENISSIMA 

www.serenissima.re.it

Tutti i formati sono nominali.

All sizes are nominal.

Tous les formats sont nominaux.

Alle Formate sind Nennwerte.

**Condizioni generali di vendita, consigli di posa e pulizia
sul sito web www.serenissima.re.it**

General terms of sale, laying and cleaning suggestion
on website www.serenissima.re.it

Conditions generales de vente, conseils de pose et de nettoyage
sur le site www.serenissima.re.it

Allgemeine verkaufsbedingungen, Verlege und reinigungshinweise
auf der webseite www.serenissima.re.it

Serenissima si riserva la facoltà di modificare in qualunque momento le informazioni e le caratteristiche illustrate nel presente catalogo, che non sono comunque da ritenere legalmente vincolanti. I colori e le caratteristiche estetiche dei prodotti sono quanto più possibile vicini a quelli reali, nei limiti consentiti dai processi di stampa. Pesì e misure possono subire variazioni tipiche del particolare processo di cottura del materiale ceramico.

Serenissima reserves the right to modify the information and the characteristics illustrated in this catalogue (which are in any case not legally binding) at any moment.

The colours and appearance features of the products are as close as possible to reality, within the limitation of the printing process. Weights and dimensions are subject to the normal variations resulting from the ceramic firing process.

Serenissima se réserve la faculté de modifier à tout moments les informations et les caractéristiques figurant dans le présent catalogue, lesquelles niengagent pas par le fabricant au plan légal.

Les couleurs et les caractéristiques esthétiques sont fidèles aux couleurs et caractéristiques réelles dans les limites des procédés diimpression. Le poids et les dimensions peuvent subir des variations, dues au processus de cuisson particulier du matériau céramique.

Die Firma Serenissima behält sich vor, die in diesem Katalog enthaltenen Informationen und Eigenschaften jederzeit zu ändern; sie gelten auf keinen Fall als gesetzlich bindend. Die Farben und ästhetischen Eigenschaften der Produkte kommen innrhalb der Möglichkeiten der Druckverfahren den tatsächlichen Eigenschaften so weit wie möglich nahe.

Gewichte und abmessungen können infolge des besonderen brennverfahrens des keramikmaterials ändern.

© Copyright 2022 Gruppo Romani S.p.A. Industrie Ceramiche: tutti i diritti riservati. Ogni riproduzione totale o parziale dei contenuti di questo catalogo, sia di testo sia di immagine, è vietata e sarà perseguita a termini di legge.

© Copyright 2022 Gruppo Romani S.p.A. Industrie Ceramiche: all rights reserved. Total or partial reproduction of text or illustration of this catalogue is prohibited and is subject to legal sanction.

© Copyright 2022 Gruppo Romani S.p.A. Industrie Ceramiche: tous droits réservés. Toute reproduction totale ou partielle du contenu - textes et images - du présent catalogue est interdite et constituerait une contrefaçon sanctionnée par la loi.

© Copyright 2022 Gruppo Romani S.p.A. Industrie Ceramiche: alle Rechte vorbehalten. Der vollständige oder auszugsweise Nachdruck des Inhalts dieses Katalog in Schrift und Bild ist verboten und wird nach Maßgabe des Gesetzes geahndet.

CE
<small>GRUPPO ROMANI S.P.A. INDUSTRIE CERAMICHE VIA A. VOLTA 9, 23/25 42013 CASALGRANDE (RE)</small>
<small>05 001CPR2013-07-01</small>
EN 14411:2012
<small>Piastrelle di ceramica pressate a secco, con assorbimento di acqua E₁ ≤ 0,5%, per pavimentazioni interne ed esterne.</small>
<small>Dry pressed ceramic tile, with water absorption E₁ ≤ 0,5%, for internal and external floorings.</small>



© Copyright 2022 Gruppo Romani S.p.A. Industrie Ceramiche

Gruppo Romani S.p.A. Industrie Ceramiche
www.grupporomanispa.com



listino prezzi

Price List - Tarif - Preisliste - Прайс-лист

Fasce di prezzo Price ranges Grupes des prix Preisgruppen	1° Scelta Mq 1st Choice Sqm 1 Choix Mc 1 Wahl Qm
A8	€ 53,00
A10	€ 55,00
A11	€ 56,00
A12	€ 57,00
A13	€ 58,00
A14	€ 59,00
A15	€ 60,00
A17	€ 62,00
A18	€ 63,00
A22	€ 67,00
A22A	€ 68,00
A23	€ 69,00
A26	€ 72,00
A26A	€ 73,00
A27	€ 74,00
A28	€ 75,00
A29	€ 76,00
A30	€ 77,00
A31	€ 78,00
A32	€ 79,00
A33	€ 80,00
A34	€ 81,00
A36	€ 84,00
A37	€ 86,00
A38	€ 87,00
A39	€ 88,00
A40	€ 89,00
A42	€ 91,00
A44	€ 93,00
A46	€ 99,00
A46E	€ 104,00
A48	€ 113,00
A53	€ 147,00
A60	€ 231,00

Fasce di prezzo Price ranges Grupes des prix Preisgruppen	1° Scelta Pz 1st Choice Piece 1 Choix Unite 1 Wahl Stück
B13	€ 16,00
B14	€ 17,00
B16	€ 19,00
B17	€ 20,00
B18	€ 21,00
B19	€ 22,00
B20	€ 23,00
B22	€ 25,00
B23	€ 26,00
B24	€ 27,00
B25	€ 28,00
B26	€ 30,00
B27	€ 32,00
B28	€ 34,00
B29	€ 35,00
B33	€ 41,00
B36	€ 51,00
B37	€ 55,00
B40	€ 61,00
B42	€ 74,00
B43	€ 78,00
B44	€ 79,00
B49	€ 93,00
B50	€ 95,00
B51	€ 99,00
B52	€ 101,00
B53	€ 108,00
B54	€ 110,00
B55	€ 112,00
B56	€ 126,00
B57	€ 130,00
B58	€ 137,00
B60	€ 142,00
B62	€ 158,00
B62C	€ 185,00
B63	€ 205,00
B63B	€ 225,00
B63C	€ 235,00
B63D	€ 245,00
B67	€ 390,00
B68	€ 410,00
B68C	€ 440,00
B71	€ 510,00
B72	€ 530,00

Fasce di prezzo Price ranges Grupes des prix Preisgruppen	1° Scelta ml 1st choice linear metre 1er choix ml 1. Wahl Lfm.
C2	€ 11,00
C3	€ 15,00
C5	€ 17,00
C6	€ 18,00
C7	€ 19,00
C8	€ 20,00



Prezzo al m²

Price x sqm
Prix / m²
Preis x qm
Цена за квадратный метр



Prezzo al pezzo

Price per piece
Prix a l'unité
Preis pro Stück
Цена за штуку



Prezzo al m lineare

Price per linear metre
Prix au m linéaire
1. Wahl Lfm.
Цена за погонный м

★

IL PREZZO DELLA SCELTA COMMERCIALE,
È DEL -50% DAL PREZZO DELLA 1ª SCELTA.

FOR COMMERCIAL GRADE TILES, A DISCOUNT OF 50% ON THE PRICE OF THE 1ST CHOICE TILES .

LE PRIX DU CHOIX COMMERCIAL, EST DE -50 % PAR RAPPORT AU PRIX DU 1ER CHOIX.

DER PREIS FÜR DIE HANDELSORTIERUNG BETRÄGT, 50 % WENIGER ALS DER PREIS FÜR DIE 1. WAHL.

TUTTI I DECORI E I BATTISCOPA SONO VENDUTI A SCATOLE INTERE.
ALL DECORS AND BASEBOARDS ARE SOLD IN FULL BOXES.
TOUS LES DECORS ET LES PLINTHES SONT VENDUS PAR BOÎTES COMPLÈTES.
FORMTEILVERKAUF NUR KARTONSWEISE MÖGLICH.

SERENISSIMA

IVA E TRASPORTO ESCLUSI.
VAT AND TRANSPORT NOT INCLUDED.
TVA ET TRANSPORT NON INCLUS.
MWST UND TRANSPORT NICHT INBEGRIFFEN.

SERENISSIMA 

DAL1968 **SERENISSIMA CERAMICHE**

www.serenissima.re.it

Via A. Volta 23/25 - 42013 Casalgrande (RE) Italy

Tel. +39 0522 998411/911

Fax Italy +39 0522 998910

Fax Export +39 0522 996218

